

WorkCentre® 3655
Multifunction Printer
Service Manual



Sample Fault Code Structure:

71-101-00



WorkCentre® 3655 Multifunction Printer

Updated 3/2017 DAW/DFK

Service Manual (without videos)

Xerox Internal-Use Only



WorkCentre 3655 Multifunction Printer

Service Documentation

WorkCentre 3655 Multifunction Printer

705P01355

Initial Issue - Xerox Internal Use Only

5/2014

Xerox Corporation

Content Development and Language Services

26600 Parkway - Bldg. 60

P.O. Box 1000, M/S 7060-776

Wilsonville, OR 97070-1000

NOTICE: All service documentation is supplied to Xerox external customers for informational purposes only. Xerox service documentation is intended for use by certified, product trained service personnel only. Xerox does not warrant or represent that such documentation is complete, nor does Xerox represent or warrant that it will notify or provide to such customer any future changes to this documentation. Customer performed service of equipment, or modules, components or parts of such equipment may affect the warranty offered by Xerox with respect to such equipment. You should consult the applicable warranty for its terms regarding customer or third party provided service. If the customer services such equipment, modules, components or parts thereof, the customer releases Xerox from any and all liability for the customer actions, and the customer agrees to indemnify, defend and hold Xerox harmless from any third party claims which arise directly or indirectly from such service.

Unpublished rights reserved under the copyright laws of the United States. Contents of this publication may not be reproduced in any form without permission of Xerox Corporation.

Copyright protection claimed includes all forms of matters of copyrightable materials and information now allowed by statutory or judicial law or hereinafter granted, including without limitation, material generated from the software programs which are displayed on the screen such as styles, templates, icons, screen displays, looks, etc.

Xerox technical training materials and service manuals are intended for use by authorized Xerox service technicians and service partners only and are not for resale. These materials may not be distributed, copied or otherwise reproduced without prior written consent from Xerox Corporation.

© 2014 Xerox Corporation. All rights reserved. XEROX® and XEROX and design®, Phaser®, PhaserSMART®, DocuCard®, DocuSP®, FreeFlow® CentreWare®, infoSMART®, Made For Each Other®, PagePack™, ColorCube®, ProfitAccelerator™, and Walk-Up™ are trademarks of Xerox Corporation in the United States and/or other countries.

Other company trademarks are also acknowledged.

As an ENERGY STAR® partner, Xerox Corporation has determined that this product meets the ENERGY STAR guidelines for energy efficiency. The ENERGY STAR name and logo are registered U.S. marks.

About This Manual	iii
How To Use This Manual.....	iii
Service Safety Summary.....	iv
Symbols Used On The Product.....	v
Voltage Measurement and Specifications.....	vi
Health and Safety Incident Reporting	vii
Regulatory Specifications.....	viii
Translation of Warnings	ix
WorkCentre 3655 Overview	x
Control Panel Layout.....	xii
Options Overview.....	xiii
CRU Life Expectancy	xiii
Product Codes and Serial Number Range.....	xiv

About This Manual

The WorkCentre 3655 Multifunction Printer Service Manual is part of a multinational service documentation system delivered in the standard Xerox EDOC service manual format. This manual is the primary document used for diagnosing, repairing, maintaining, and troubleshooting these systems. The Service Manual is the controlling publication for a service call. To ensure product understanding, complete the Xerox Service Training Program for this printer.

Organization

Section titles and the information contained in each is presented in the following paragraphs:

Section 1 Service Call Procedures

This section is used to start and complete a service call. The procedures in this section will either direct you to a Repair Analysis Procedure (RAP), or identify a faulty component or sub-assembly.

Section 2 Status Indicator Repair Analysis Procedures

This section contains the Repair Analysis Procedures (RAPs) and checkouts necessary to diagnose, isolate and repair faults other than image quality faults.

Section 3 Image Quality

This section contains the Image Quality Repair Analysis Procedures (IQ RAPs), checkouts and setup procedures necessary to diagnose, isolate and repair image quality faults.

Section 4 Repairs/Adjustments

This section contains the instructions for removal, replacement, and adjustment of parts.

Section 5 Parts List

This section contains the illustrated spare parts list. Any part that is spared or that must be removed to access a spared part is illustrated.

Section 6 General Procedures / Information

This section contains all other procedures, product specifications and general information.

Section 7 Wiring Data

This section contains the wiring diagrams.

Section 8 Principles of Operation

This section contains details of printer operation and component locations.

Component Names

Names of parts that appear in the disassembly procedures may not be exactly the same as the names that appear on the part or listed in the Parts List. For example; a part called the Registration Chute Assembly may appear on the Parts List as Assembly, Chute REGI.

How To Use This Manual

Always start with the Service Call Procedures, Section 1. Perform Initial Actions and verify the problem, then follow the directions given.

How to Differentiate Between Machine Variants

The machine will be identified in this manual by the model identifier 3655N/DN or 3655SN/DN.

When a procedure, parts list description or other reference is unique amongst different models of machine, the appropriate model designator is indicated. Any artwork is also specific.

NOTE: *This manual services all configurations of the machine. Ignore references to options not installed on the machine.*

Warnings, Cautions and Notes

WARNING

A warning is used whenever an operating or maintenance procedure, practice, condition or statement, if not strictly observed, could result in personal injury.

A translated version of all warnings is in Translation of Warnings.

CAUTION

A caution is used whenever an operation or maintenance procedure, practice, condition or statement, if not strictly observed, could result in damage to the equipment.

NOTE: *A note appears to highlight a procedure, practice, condition or statement.*

Service Safety Summary

General Guidelines

For qualified service personnel only: Refer also to the preceding Electrical Safety.

Avoid servicing alone: Do not perform internal service or adjustment of this product unless another person capable of rendering first aid or resuscitation is present.

Use care when servicing with power applied: Dangerous voltages may exist at several points in this product. To avoid personal injury, do not touch exposed connections and components while power is on. Disconnect power before removing the power supply shield or replacing components.

Do not wear jewelry: Remove jewelry prior to servicing. Rings, necklaces and other metallic objects could come into contact with dangerous voltages and currents.

Electrical Safety

- Use the Power Cord supplied with the printer.
- Plug the Power Cord directly into a properly grounded electrical outlet.
- Do not use a ground adapter plug to connect the printer to an electrical outlet that does not have a ground connection terminal.
- Do not use an extension cord or power strip.
- Do not place the system in an area where people might step on the power cord.
- Do not place objects on the power cord.
- Do not block ventilation openings. These openings prevent printer overheating.
- Do not drop paper clips or staples into the printer.

Operational Safety

The printer and supplies were designed and tested to meet strict safety requirements. These include safety agency examination, approval, and compliance with established environmental standards.

Pay attention to these safety guidelines to ensure the continued, safe operation of the printer.

- Use the supplies specifically designed for your system. The use of unsuitable materials may cause poor performance and a possible safety hazard.
- Follow all warnings and instructions marked on, or supplied with, the system, options and supplies.

NOTE: *The Total Satisfaction Guarantee is available in the United States and Canada. Coverage may vary outside these areas; please contact your local representative for details.*

Maintenance Safety

- Do not attempt maintenance not specifically described in the printer documentation.
- Do not use aerosol cleaners. The use of supplies that are not approved may cause poor performance and could create a hazardous condition.
- Do not burn any consumables or routine maintenance items. For information on Xerox supplies recycling programs, go to www.xerox.com/gwa.

Warning Labels

Read and obey all posted warning labels. Throughout the printer, warning labels are displayed on potentially dangerous components. As you service the printer, check to make certain that all warning labels remain in place.

Safety Interlocks

Make sure all covers are in place and all interlock switches are functioning correctly after you have completed a service call. If you bypass an interlock switch, use extreme caution when working on or around the printer. Figure 1 shows the interlock circuitry.

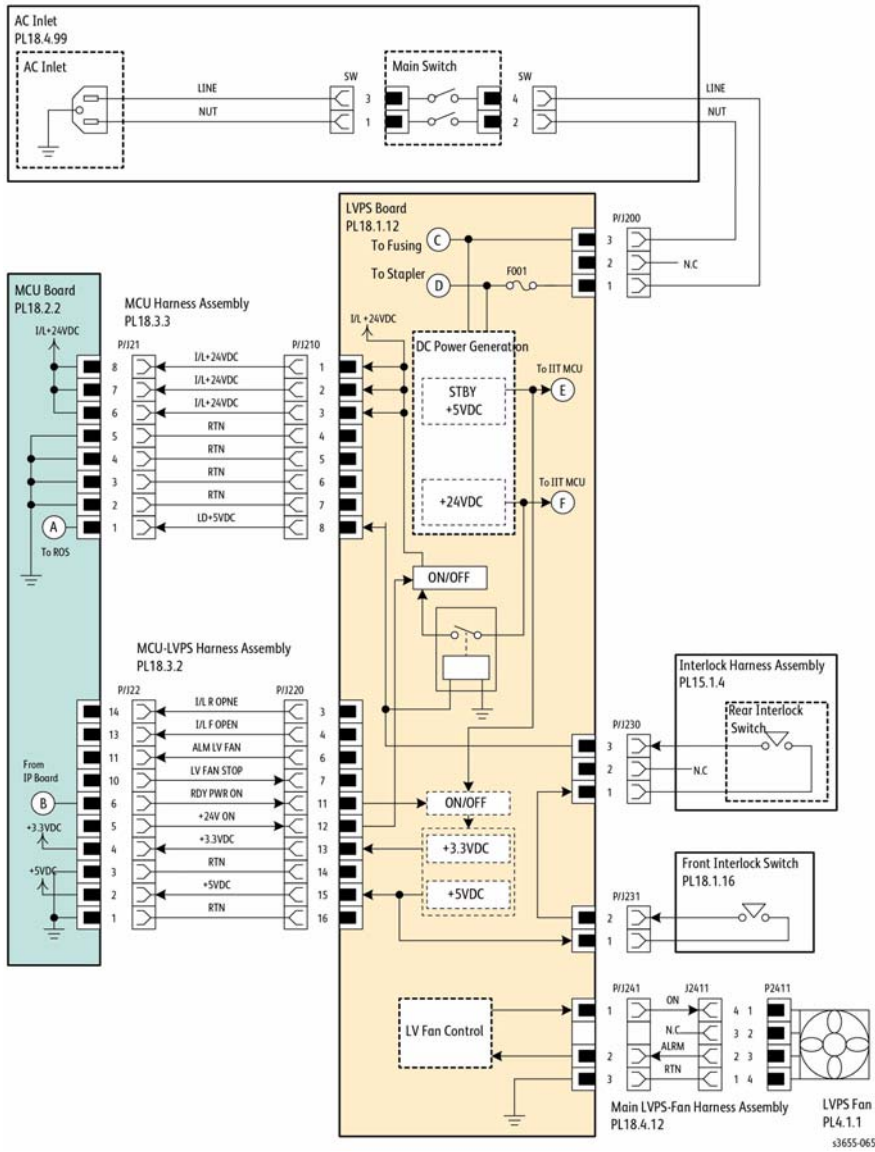

Figure 1 Interlock circuits

Symbols Used On The Product

The following precautionary symbols may appear on the machine.

This symbol indicates Danger High Voltage.



Figure 1 High voltage symbol

Protective Ground (Earth) symbol.



Figure 2 Protective ground (earth) symbol

This symbol indicates hot surface. Use caution to avoid personal injury.



Figure 3 Hot surface symbol

The surface is hot while the printer is running. After turning off the power, wait 30 minutes.



Figure 4 Wait 30 minutes symbol

Avoid pinching fingers in the printer. Use caution to avoid personal injury.



Figure 5 Pinch injury symbol

Use caution (or draws attention to a particular component). Refer to the manual(s) for information.



Figure 6 Use caution symbol

Voltage Measurement and Specifications

Measurements of DC voltage must be made with reference to the specified DC Common, unless some other point is referenced in a diagnostic procedure. All measurements of AC voltage should be made with respect to the adjacent return or ACN wire.

Table 1 Voltage Measurement and Specifications

Voltage	Specification
Input Power 220 V	198 VAC TO 254 VAC
Input Power 120 V	90 VAC TO 135 VAC
+3.3 VDC	+2.75 VDC TO +3.25 VDC
+5 VDC	+4.75 VDC TO +5.25 VDC
+24 VDC	+23.37 VDC TO +27.06 VDC

Logic Voltage Levels

Measurements of logic levels must be made with reference to the specified DC Common, unless some other point is referenced in a diagnostic procedure.

Table 2 Logic Levels

Voltage	H/L Specification
+5 VDC	H = +3.00 V or greater L = below 0.8 V
+3.3V	H = +2 V or greater L =below 0.8 V

DC Voltage Measurement in RAPs

The RAPs have been designed so that when it is required to use the DMM to measure a DC voltage, the first test point listed is the location for the red (+) meter lead and the second test point is the location for the black meter lead. For example, the following statement may be found in a RAP.

There is +5 VDC from P/J7 to P/J68.

In this example, the red meter lead would be placed on P/J7 and the black lead on P/J68.

If a second test point is not given, it is assumed that the black meter lead may be attached to chassis ground.

Health and Safety Incident Reporting

I. Summary

This section defines requirements for notification of health and safety incidents involving Xerox products (equipment and materials) at customer locations.

II. Scope

Xerox Corporation and subsidiaries worldwide.

III. Objective

To enable prompt resolution of health and safety incidents involving Xerox products and to ensure Xerox regulatory compliance.

IV. Definitions

Incident:

An event or condition occurring in a customer account that has resulted in injury, illness or property damage. Examples of incidents include machine fires, smoke generation, physical injury to an operator or service representative. Alleged events and product conditions are included in this definition.

V. Requirements

Initial Report:

1. Xerox organizations shall establish a process for individuals to report product incidents to Xerox Environment Health & Safety within 24 hours of becoming aware of the event.
2. The information to be provided at the time of reporting is contained in Appendix A (Health and Safety Incident Report involving a Xerox product).
3. The initial notification may be made by any of the following methods:
 - For incidents in North America and Developing Markets West (Brazil, Mexico, Latin American North and Latin American South):
 - Phone* Xerox EH&S at: 1-800-828-6571.
 - Electronic mail to Xerox EH&S
 - Fax Xerox EH&S at: 1-585-422-6449 [intelnet 8*222 6449].
 - For incidents in Europe and Developing Markets East (Middle East, Africa, India, China and Hong Kong):
 - Phone* Xerox EH&S at: +44 (0) 1707 353434.
 - Electronic mail Xerox EH&S at: Elaine.Grange@xerox.com.
 - Fax Xerox EH&S at: +44 (0) 1707 353914 [intelnet 8*668 3914].

*Initial notification made by phone must be followed within 24 hours by a completed incident report and sent to the indicated electronic mail address or fax number.

NOTE: If sending a fax, please also send the original via internal mail.

Responsibilities for resolution:

1. Business Groups/Product Design Teams responsible for the product involved in the incident shall:
 - a. Manage field bulletins, customer correspondence, product recalls, safety retrofits.
 - b. Fund all field retrofits.

2. Field Service Operations shall:
 - a. Preserve the Xerox product involved and the scene of the incident inclusive of any associated equipment located in the vicinity of the incident.
 - b. Return any affected equipment/part(s) to the location designated by Xerox EH&S and/or the Business Division.
 - c. Implement all safety retrofits.
3. Xerox EH&S shall:
 - a. Manage and report all incident investigation activities.
 - b. Review and approve proposed product corrective actions and retrofits, if necessary.
 - c. Manage all communications and correspondence with government agencies.
 - d. Define actions to correct confirmed incidents.

Regulatory Specifications

Xerox has tested this product to electromagnetic emission and immunity standards. These standards are designed to mitigate interference caused or received by this product in a typical office environment.

United States (FCC Regulations)

The Wentre 3655 has been tested and found to comply with the limits for a Class A digital device pursuant to Part 15 of the FCC Rules. These limits are designed to provide reasonable protection against harmful interference in a commercial installation. This equipment generates, uses, and can radiate radio frequency energy. If it is not installed and used in accordance with these instructions, it may cause harmful interference to radio communications. Operation of Class A equipment in a residential area is likely to cause harmful interference in which case the user will be required to correct the interference at his/her own expense. There is no guarantee that interference will not occur in a particular installation.

If this equipment does cause harmful interference to radio or television reception, which can be determined by turning the equipment Off and On, the user is encouraged to try to correct the interference by one or more of the following measures:

- Reorient or relocate the receiver.
- Increase the separation between the equipment and receiver.
- Connect the equipment to a different electrical circuit.
- Consult the dealer or an experienced radio/television technician for help.

Any modifications not expressly approved by Xerox could void the user's authority to operate the equipment. To ensure compliance with Part 15 of the FCC rules, use shielded interface cables.

Canada (Regulations)

This Class A digital apparatus complies with Canadian ICES-003.

Cet appareil numérique de la classe A est conforme à la norme NMB-003 du Canada.

European Union

CE Mark



The CE mark applied to this product symbolizes Xerox's declaration of conformity with the following applicable Directives of the European Union as of the dates indicated:

Figure 1 CE Symbol

December 12, 2006: Low Voltage Directive 2006/95/EC

December 15, 2004: Electromagnetic Compatibility Directive 2004/108/EC

This product, if used properly in accordance with the user's instructions, is neither dangerous for the consumer nor for the environment.

To ensure compliance with European Union regulations, use shielded interface cables.

A signed copy of the Declaration of Conformity for this product can be obtained from Xerox.

Translation of Warnings

WARNING

Switch off the electricity to the machine. Disconnect the power cord from the customer supply while performing tasks that do not need electricity. Electricity can cause death or injury. Moving parts can cause injury.

DANGER : Mettez la machine hors tension. Déconnectez le cordon d'alimentation de l'alimentation du client lorsque vous réalisez des tâches qui ne nécessitent pas d'électricité. L'électricité peut être à l'origine de blessures, voire d'un accident mortel. Les pièces amovibles peuvent être à l'origine de blessures.

AVVERTENZA: Spegner la macchina. Scollegare il cavo di alimentazione dall'alimentatore quando si eseguono attività che non richiedono elettricità. L'elettricità può causare morte o lesioni personali. Le parti in movimento possono causare lesioni personali.

VORSICHT: Schalten Sie die Stromversorgung der Maschine ab. Ziehen Sie das Stromkabel ab, wenn Sie Aufgaben ausführen, für die keine Stromversorgung benötigt wird. Stromschläge können Todesfällen oder Verletzungen verursachen. Bewegliche Teile können zu Verletzungen führen.

AVISO: Apague la electricidad de la máquina. Desconecte el cable de alimentación eléctrica de la toma de pared mientras esté realizando tareas que no necesiten corriente. La electricidad puede causar daños o la muerte. Las partes móviles pueden causar daños.

WARNING

Do not work in a confined space. 1 m (39 inches) space is needed for safe working.

DANGER : Ne pas travailler dans un espace restreint. 1 mètre d'espace est nécessaire pour un dépannage en toute sécurité.

AVVERTENZA: Non lavorare in uno spazio limitato; è necessario uno spazio di almeno un metro attorno alla macchina per la sicurezza dell'operatore.

VORSICHT: Nur mit ausreichendem Bewegungsspielraum (1 m) arbeiten.

AVISO: No trabaje en un espacio reducido. Se necesita 1 metro de espacio para trabajar con seguridad.

WARNING

Use safe handling procedures when removing the module. Refer to GP 16. The module is heavy.

DANGER: Conformez-vous aux procédures de manipulation de sécurité pour le retrait du module. Reportez-vous à GP 16. Le module est lourd.

AVVERTENZA: Utilizzare procedure di gestione sicure durante la rimozione del modulo. Vedere GP 16. Il modulo è pesante.

VORSICHT: Verwenden Sie sichere Vorgehensweisen zum Entfernen des Moduls. Siehe auch GP 16. Das Modul ist sehr schwer.

AVISO: Utilice los procedimientos de seguridad cuando elimine el módulo. Consulte el GP 16. El módulo es pesado.

WARNING

Follow the service procedure exactly as written. Use of controls or adjustments other than those specified in this manual, may result in an exposure to invisible laser radiation. During servicing, the invisible laser radiation can cause eye damage if looked at directly.

DANGER : Les procédures de dépannage doivent être suivies à la lettre. Si les réglages ou vérifications ne sont pas effectués suivant les instructions de ce manuel, il peut y avoir un risque d'exposition dangereuse au faisceau laser. Celui-ci peut provoquer des lésions oculaires s'il est observé directement.

AVVERTENZA: Eseguire le procedure di servizio esattamente come descritto. L'utilizzo di dispositivi di controllo o di registrazione diversi da quelli riportati in questo manuale potrebbe comportare un'esposizione a radiazioni laser invisibili. Tali radiazioni possono danneggiare gli occhi se si guarda direttamente il fascio laser durante gli interventi di servizio.

VORSICHT: Die Wartungsarbeiten genau den Anweisungen entsprechend durchführen. Der Umgang mit Steuer- oder Bedienelementen, deren Verwendung nicht ausdrücklich in diesem Handbuch angewiesen wurde, kann dazu führen, dass unsichtbare Laserstrahlung frei gesetzt wird. Direkter Blickkontakt mit dem Laserstrahl kann bleibende Augenschäden verursachen.

AVISO: Siga los procedimientos de mantenimiento tal como están descritos. El uso de controles o ajustes no especificados en este manual puede tener como resultado la exposición a radiación láser invisible. Durante las operaciones de mantenimiento, la radiación de láser invisible puede causar daños en los ojos si se mira directamente a ella.

WARNING

USA and Canada. Do not install this machine in a hallway or exit route that does not have 1.12 m (44 inches) of space additional to the normal space requirements in front of the machine. To conform with fire regulations this additional 1.12 m (44 inches) of space is needed in front of the machine in hallway and exit routes.

DANGER : États-Unis et Canada. Si cette machine est installée dans un couloir ou une voie de sortie, 1,12 m (44 pouces) d'espace supplémentaire à l'espace normal doit être disponible devant la machine conformément aux normes de sécurité d'incendie.

AVVERTENZA: N/A

VORSICHT: N/A

AVISO: Estados Unidos y Canadá. No instale esta máquina en un corredor o ruta de salida que no tenga 1.12 m (44 pulgadas) de ancho delante de la máquina, sin incluir el espacio que ocupe la máquina. Este espacio adicional de 1.12 m (44 pulgadas) delante de la máquina en corredores y rutas de salida es necesario para cumplir los requisitos de las normas sobre incendios.

WARNING

Use only Xerox materials and components. This product is safety certified using Xerox materials and components. The use of non Xerox materials and components may invalidate the safety certificate.

DANGER : N'utilisez que des matières premières et des composants Xerox. La sécurité du produit est assurée dans le cadre de son utilisation avec des matières premières et des composants Xerox. L'utilisation de matières premières et de composants autres que ceux de Xerox risque d'invalider le certificat de sécurité.

AVVERTENZA: Utilizzare solo materiali e componenti Xerox per avvalersi della certificazione di protezione. L'utilizzo di materiali e componenti non Xerox può rendere nulla la certificazione di protezione.

VORSICHT: Verwenden Sie nur Materialien und Komponenten von Xerox. Dieses Produkt besitzt die Sicherheitszertifizierung bei Verwendung von Xerox-Materialien und -Komponenten. Die Verwendung von Materialien und Komponenten anderer Hersteller setzt möglicherweise das Sicherheitszertifikat außer Kraft.

AVISO: Utilice solo los materiales y componentes Xerox. Este producto dispone de un certificado de seguridad si se utilizan los materiales y componentes Xerox. Este certificado de seguridad no será válido si se utilizan materiales y componentes que no sean de Xerox.

WARNING

Do not touch the fuser while it is hot.

DANGER : Ne pas toucher au four pendant qu'il est encore chaud.

AVVERTENZA: Non toccare il fonditore quando è caldo.

VORSICHT: Fixierbereich erst berühren, wenn dieser abgekühlt ist.

AVISO: No toque el fusor mientras está caliente.

WorkCentre 3655 Overview

The WorkCentre 3655 in either 4in1 (S) or 3in1 (X) configurations combine a monochrome laser print engine with a scanner and Duplex Automatic Document Feeder (DADF), Tray 1. The Output Tray holds 250 20lb. sheets facedown. WorkCentre 3655 options add media capacity, wireless connectivity, and functionality. Configurations of up to three additional 550-Sheet Feeders are supported. Figure 1 illustrates components accessible from the front.

Front View

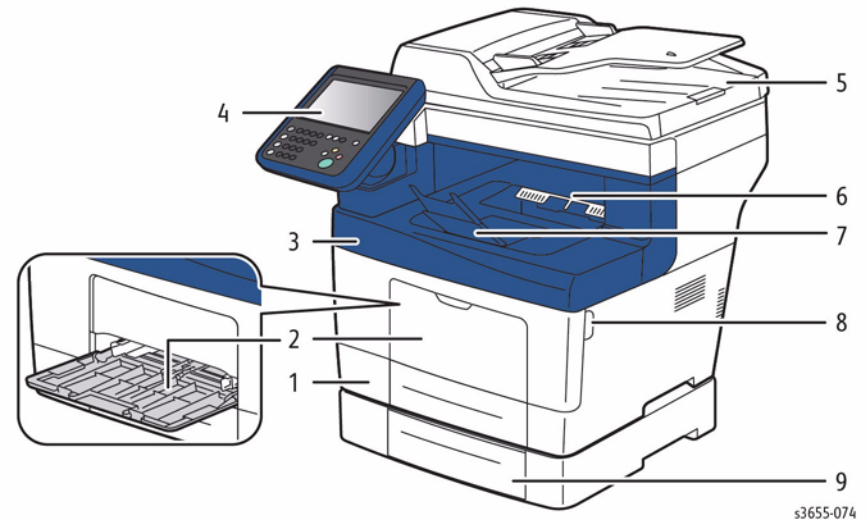

Figure 1 Front View

Front View

- | | |
|-------------------------------------|------------------------------|
| 1. Tray 1 | 6. Output Tray |
| 2. Bypass Tray | 7. Output Tray Extension |
| 3. Top Cover | 8. Front Cover Release |
| 4. Control Panel | 9. Optional 550-sheet Feeder |
| 5. Automatic Document Feeder (DADF) | |

Internal View

Figure 2 shows other system features.

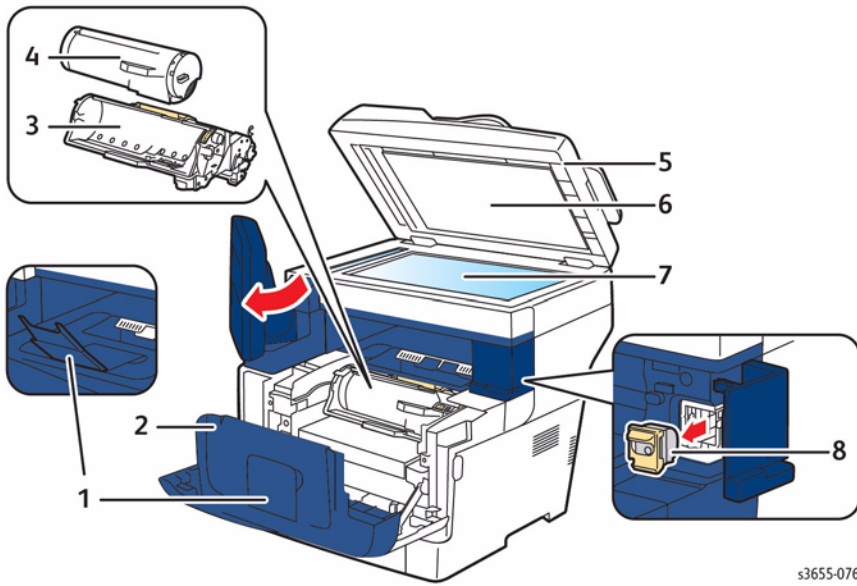

Figure 2 Internal view

s3655-076

Rear View

- | | |
|--------------------------|---------------------------------------|
| 1. Output Tray Extension | 5. Duplex Auto Document Feeder (DADF) |
| 2. Front Cover Assembly | 6. DADF Top Cover |
| 3. Drum Cartridge | 7. Scanner Platen |
| 4. Toner Cartridge | 8. Stapler Cartridge (3655S only) |

Rear View

Figure 3 shows features located at the rear of the system.

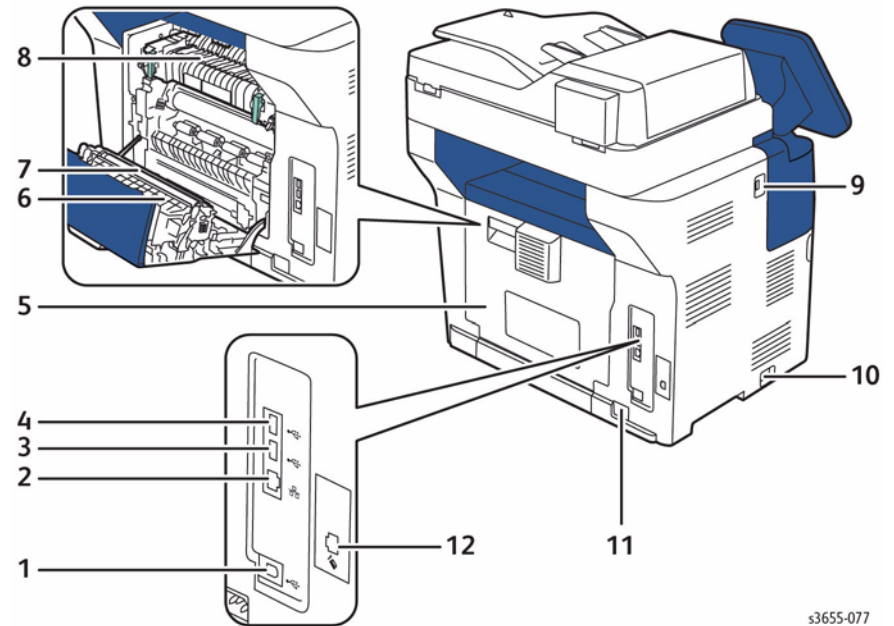

Figure 3 WorkCentre 3655S 4-in-1 rear view

s3655-077

Rear View

- | | |
|---------------------|--------------------|
| 1. USB Port (slave) | 7. Transfer Roller |
| 2. Ethernet Port | 8. Fuser |
| 3. USB Port (host) | 9. USB Port (host) |
| 4. USB Port (host) | 10. Power Switch |
| 5. Rear Door | 11. AC Input |
| 6. Duplex Chute | 12. FAX Connection |

Control Panel Layout

The WorkCentre 3655 Control Panel consists of a touchscreen, a keypad, and several buttons. These buttons are used to navigate the menu system, perform functions, and select operational modes.

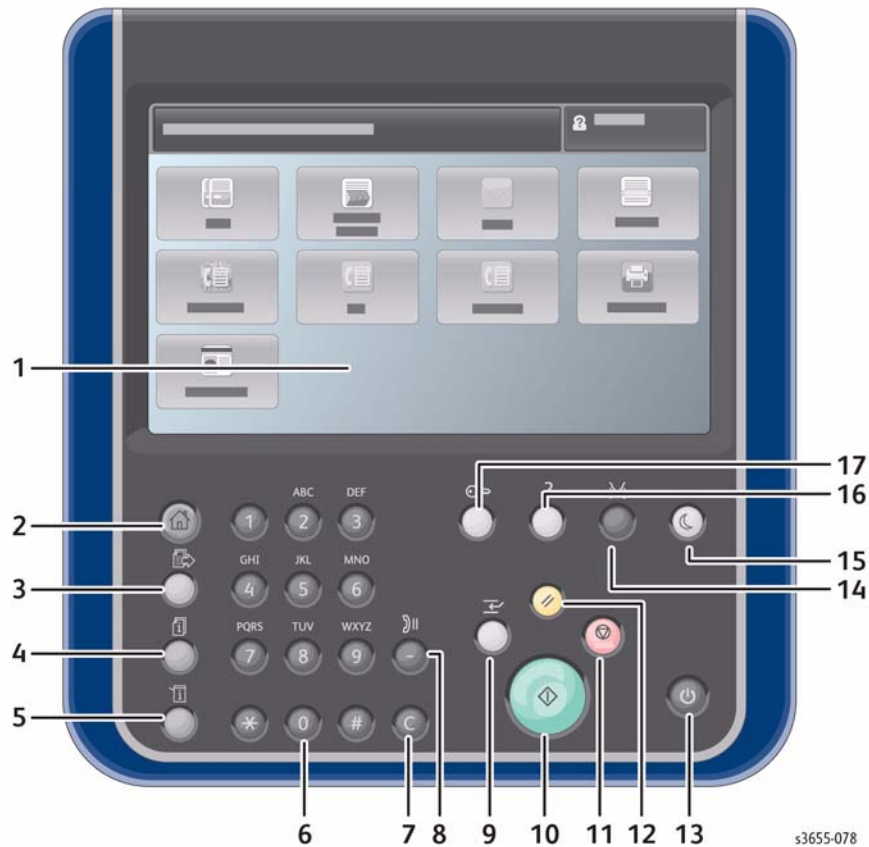

Figure 1 Control Panel

Control Panel Features

Item	Description
1. Display	Touchscreen display of printer settings, status, messages and menus
2. Services Home	Services Home displays services, such as copy, scan, and fax
3. Services	Returns to the active service from the Job Status or Machine Status screens, or to a preset service
4. Job Status	Displays active, held, and completed jobs
5. Machine Status	Displays settings and information

Control Panel Features

6. Keypad	Enter alphanumeric characters
7. Clear	Deletes numeric values or the last digit entered
8. Pause	TBD.
9. Interrupt Print	Pauses the currently printing job to run a more urgent job.
10. Start	Start the selected job
11. Stop	Stops the current job. Follow the onscreen instructions to cancel or resume the job
12. Clear All	Clears previous and changed settings for the current service. Press twice to reset all defaults and clear existing scans
13. Power	Restart or shuts down the printer
14. Language	Changes the touch screen language and keyboard settings
15. Sleep	Enter a reduced power mode
16. Help	Displays additional information about the current selection or service
17. Log In / Log Out	Access password protected features following login

Options Overview

WorkCentre 3655 options include:

- 550-sheet Feeder
- USB wireless network adaptor
- Printer stand

550-Sheet Feeder

The Optional 550-sheet Feeder adds a single, 550-sheet tray. The printer supports up to three 550-sheet feeders. The feeder is secured to the print engine with two screws located under the front edge of Tray 1.

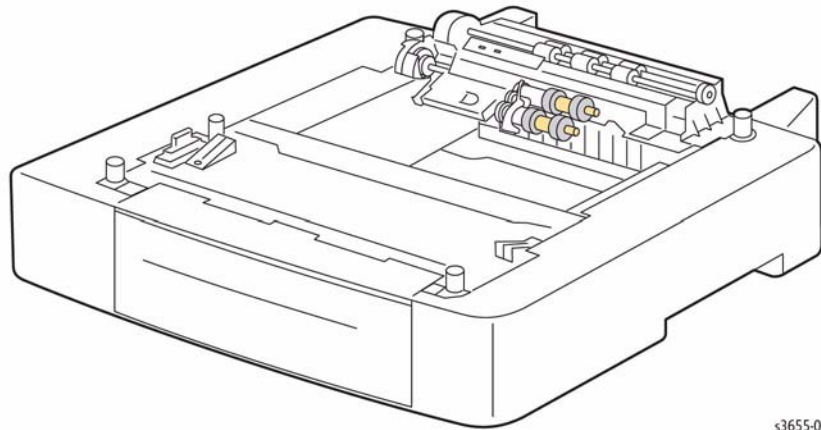

s3655-079

Figure 1 550-Sheet Feeder

CRU Life Expectancy

The rated life expectancy of WorkCentre 3655 consumables are listed in Table 1.

Table 1 CRU and Consumable Life Expectancy

Description	Print Life
Standard Toner Cartridge Capacity	6,100 cycles
High Toner Cartridge Capacity	14,400 cycles
Extra High Toner Cartridge Capacity	25,900 cycles
Metered Toner Cartridge Capacity	30,000 cycles
Drum Cartridge	85,000 cycles
Staple Cartridge	50,000 cycles
Maintenance Kit (Fuser, Transfer Roller)	200,000 cycles
Feed Roller Kit	100,000 cycles

Product Codes and Serial Number Range

Product codes are listed in Table 1. Serial number ranges for each product appear in Table 2.

Table 1 Product Codes

Product	Code
3655_SM 110V (Metered, 3in1 Copy, Print, Scan)	C4X
3655_S 110V (Sold, 3in1 Copy, Print, Scan)	C4XD
3655V_SM 220V (Metered, 3in1 Copy, Print, Scan)	C5X
3655V_S 220V (Sold, 3in1 Copy, Print, Scan)	C5XD
3655_XM 110V (Metered, 4in1 Copy, Network Print, Scan, Fax, stapler)	C7X
3655_X 110V (Sold, 4in1 Copy, Network Print, Scan, Fax, stapler)	C7XE
3655_YXM 110V (Metered, 4in1 Copy, Network Print, Scan, Fax, stapler, TAA-compliant)	C7XR
3655V_XM 220V (Metered, 4in1 Copy, Network Print, Scan, Fax, stapler)	C8X
3655V_X 220V (Metered, 4in1 Copy, Network Print, Scan, Fax, stapler)	C8XD

Table 2 Serial Number Range

Product	Serial Number Range
3655_SM 110V C4X	155,000
3655_S 110V C4XD	000501 -015500 025501 - 165500
3655V_SM 220V C5X	60,000
3655V_S 220V C5XD	015501 -025500 165501-215500
3655_XM 110V C7X	100,000 215501-315500
3655_YXM 110V C7XR	TBD
3655_X 110V C7XE	40000 365501-40550
3655V_XM 220V C8X	50,0000
3655V_X 220V C8XD	315501-365500

1 Service Call Procedures

Service Call Procedures.....	1-3
SCP 1 Initial Actions.....	1-4
SCP 2 First Call Actions.....	1-4
SCP 3 Normal Call Actions.....	1-5
SCP 4 Fault Analysis.....	1-5
SCP 5 Subsystem Maintenance.....	1-6
SCP 6 Final Actions.....	1-7
SCP 7 Configurations and Options.....	1-8

Service Call Procedures

This section provides an overview of the steps a service technician should take to service the printer and attached options. The printer's diagnostic routines report problems using error messages and fault codes displayed on the Control Panel, logged in the Service Usage Profile, or by flashing LEDs. These error indications serve as the entry point into the troubleshooting process. System problems not directly indicated by or associated with an error message or fault code are covered in Section 6, General Procedures. Print-quality problems are covered in Section 3, Image Quality.

The steps listed here are a guide for performing any service on this printer. If you choose not to use these steps, it is recommended that you start at the appropriate troubleshooting procedure and proceed from there. When servicing the printer, follow the safety measures detailed in the Service Safety Summary section.

1. Identify the problem.
 - Verify the reported problem does exist.
 - Check for any error codes and write them down.
 - Print normal customer prints and service test prints.
 - Make note of any print-quality problems in the test prints.
 - Make note of any mechanical or electrical abnormalities present.
 - Make note of any unusual noise or smell coming from the printer.
 - Print a Usage Profile, if the printer is able to print.
 - View the Engine Error and Jam Histories under the Tools menu.
 - Verify the AC input from the wall outlet is within specifications.
2. Inspect and clean the printer.
 - Follow the cleaning instructions.
 - Verify that the power cord is in serviceable condition.
 - Restart the printer to check if the error reoccurs.
3. Find the cause of the problem.
 - Use the troubleshooting procedures to find the root cause of the problem.
 - Use Service Diagnostics to check the printer and optional components.
 - Use the Wiring Diagrams and Plug/Jack Locator to locate test points.
 - Take voltage readings as instructed in the troubleshooting procedure.
4. Correct the problem.
 - Use the Parts List to locate a part number.
 - Use the Repair procedures to replace the part.
5. Final Checkout
 - Test the printer to verify the problem is corrected and no new problems arose.

Accessing Engine Fault History

Listed below are three ways in which you can access fault history. Additional fault history information appears in GP 2.

NOTE: Error and fault code definitions appear in Section 2.

1. Read (if possible) fault history from the Machine Status menu on the Control panel. The error history is listed on screen.

2. Accessing fault history in Service Diagnostics, GP 1.
 - a. Enter Service Diagnostics.
 - b. Touch Service Info.
 - c. Touch dC122 Fault History.
3. If the printer is connected to a network and has an IP address, view the printer's web page using a web browser.
 - a. Open a web browser.
 - b. Enter the printer's IP address as the URL.
 - c. Select **Support --> Troubleshooting --> Diagnostics Logs** and the fault history displays.

SCP 1 Initial Actions

Initial Actions are used to gather information on printer performance

Start a service call with SCP 1 and end with SCP 6 Final Actions.

Also refer to SCP 7 Configurations and Options.

Procedure

WARNING

Switch off the electricity to the machine. Disconnect the power cord from the customer supply while performing tasks that do not need electricity. Electricity can cause death or injury. Moving parts can cause injury.

WARNING

Do not work in a confined space. 1m (39 inches) space is needed for safe working.

NOTE: Ignore references to options not installed on the printer.

1. Take note of symptoms or error messages.
2. Ask the operator to describe or demonstrate the problem.
3. Make sure:
 - a. The power cord is connected to the wall outlet and to the machine.
 - b. Paper is loaded correctly and all paper trays and covers are closed
 - c. If installed, the USB cable or network connection is installed correctly.
4. If available, check the service log book for any previous actions that may be relevant to the call.
5. If this is the first service call to this printer, perform SCP 2 First Call Actions, otherwise go to SCP 3 Normal Call Actions.

SCP 2 First Call Actions

First Call Actions are used for the first service call.

Procedure

1. Check the machine configuration with the customer, refer to SCP 7 Configurations and Options. Check that all required hardware and software is installed and/or enabled.
2. Check that all the relevant machine settings are correctly entered, refer to GP 3 Customer Administration Tools.
3. If a fault is present, go to SCP 3 Normal Call Actions. If there is no fault present, go to SCP 6 Final Actions.
4. Enter the printer and customer details in the service log.

SCP 3 Normal Call Actions

Normal Call Actions are used to determine the reason for the service call.

Procedure

NOTE: If a fault message appears at any time. Refer directly to the RAP for the fault message and perform the procedure.

If possible, perform the following:

1. Review any defective print samples.
2. Determine that the user accessible settings are correct. If necessary refer to the user documentation.
3. Check all job queues and verify with the customer any requirement to print the documents in memory, before switching off the power or clearing memory.
4. Print the Customer Assistance Report (Call for Assistance), then record the total print count.
5. Go to SCP 4 Fault Analysis.

SCP 4 Fault Analysis

Fault Analysis is used to identify a fault.

Procedure

When diagnosing or repairing a fault in a particular subsystem, exercise the machine in all modes until the fault is determined. In the instance of finding more than one fault or failure, correct one fault before going to the next fault. If no fault is found, go to SCP 5 Subsystem Maintenance.

Fault Codes

If a fault code is displayed, go to the relevant RAP.

Control Panel Faults

If the power is on but the Control Panel is blank, go to the [OF 7 RAP](#).

Stapler Faults

If the machine has a stapler fault, test the Stapler with dC330.

Image Quality Defects

If the image quality is defective, go to the IQ1 Image Quality Entry RAP.

For image quality specifications, refer to the following:

- IQS 1 Solid Area Density.
- IQS 2 Skew.
- IQS 3 Registration.

Additional Information

If necessary, refer to the following general procedures and information:

- GP 1 Service Diagnostics Entry and Exit
- GP 2 Fault Codes and History Logs
- GP 3 Customer Administration Tools
- GP 4 How to Switch Off or Switch On the Printer
- GP 5 Service Copy (Tools) Mode
- GP 6 Electrostatic Discharge Prevention
- GP 7 Machine Specifications
- GP 8 General Disassembly Precautions
- GP 9 Installing System Software
- GP 10 How to Check a Motor
- GP 11 How to Check a Sensor
- GP 12 How to Check a Solenoid or Clutch
- GP 13 How to Check a Switch
- GP 14 Cloning Network Configurations
- GP15 -Removed-
- GP 16 Separate System Modules
- GP 17 External FAX Line Test

- GP 18 Printing Reports
- GP 19 Intermittent or Noise Problem
- GP 20 How to Safely Lift or Move Heavy Modules
- GP 21 Machine Lubrication
- GP 22 Installation Space Requirements
- GP 23 First Print Output Time (FPOT)
- GP 24 Restriction of Hazardous Substances (RoHS)
- GP 25 Remote Control Panel
- GP 26 Media Specifications
- GP 27 Environmental Data
- GP 28 Toner CRUM Conversion

SCP 5 Subsystem Maintenance

Subsystem Maintenance contains information regarding the component life of the machine.

Procedure

WARNING

Switch off the electricity to the machine. Disconnect the power cord from the customer supply while performing tasks that do not need electricity. Electricity can cause death or injury. Moving parts can cause injury.

1. Clean the Pick Rollers on every call.
2. Use the Control Panel to check maintenance item counters.
3. Compare the counter values to those listed in Component Life.
4. Advise the customer of any routine maintenance items that are approaching or over the service limit.

Inspection

Rollers

Replace rollers when you see any of the following defects:

- Flat spots
- Out of roundness
- Cracked rubber
- Loss of traction (tackiness) causing pick or feed failures

Gears

Replace gears that show any signs of wear or damage. Look for these problems:

- Thinned gear teeth
- Bent or missing gear teeth; check especially where a metal gear drives a plastic gear.
- Fractured or cracked gears (oil or incorrect grease on a plastic gear can cause the gear to crack).

Lubrication

The printer is lubricated during assembly at the factory and does not require periodic lubrication. Some parts require lubrication following replacement. These parts are identified in the replacement procedures. When lubricating during replacement, use approved grease.

CAUTION

Plastic parts deteriorate when unspecified lubricants or chemicals are used. To avoid damage, use only Rheolube 768 grease.

- Rheolube 768 Grease: Part Number 070E00890

Component Life

The design life of the major components are shown in Table 1. Environmental conditions and actual use will vary these factors. The component life shown in Table 1 is for reference only.

Table 1 Component Life Expectancies

Item	Description	Print Life
1.	Pick and Nudger Rollers	100,000 pages

Table 1 Component Life Expectancies

Item	Description	Print Life
2.	Separator Roller	100,000 pages
3.	Transfer Roller	200,000 images
4.	Fuser	200,000 images
5.	Feed Roller	100,000 pages

HFSI

The High Frequency Service Items are shown in Table 2.

Table 2 High Frequency Service Items

Item	Description	Life	Reference
Bypass Tray Pick Roller	Sheets fed from Tray 1 after last reset.	100k feeds	PL 13.1 Item 15
Tray 1 Pick Roller	Sheets fed from Tray 1 after last reset.	100k feeds	PL 9.2 Item 98
Optional Tray Pick Rollers	Sheets fed from Tray 2 after last reset.	100k feeds	PL 11.3 Item 98
Maintenance Kit	Total prints after the last reset.	200k impressions	Fuser and Transfer Roller

SCP 6 Final Actions

Final Actions are used to evaluate the total operation of the system and to identify the actions required to complete the service call.

Procedure

Complete the following, if a fault is identified, return to SCP 4 Fault Analysis:

- Perform the end of call subsystem maintenance actions, SCP 5 Subsystem Maintenance.
- Exercise the machine in all modes, printing from all trays. If a fault message is displayed or some other problem is evident, go to SCP 4 Fault Analysis.
- Make a print of a customer document.
- If any of the customers selections were changed, return them to the customers preferred settings. Refer to GP 3 Customer Administration Tools.
- At the first service and at any subsequent service where changes are made or options are added, print the configuration report and store it with machine log book. Discard any previous versions of the configuration report.
- Remove and destroy any copies of test patterns.
- Ensure the machine and service area are clean before leaving the customer premises.
- Provide customer training if required.

SCP 7 Configurations and Options

Configurations and Options

Refer to Table 1 for basic configurations and options. This service manual covers all configurations. Within this manual ignore any references to options that are not installed.

Table 1 WorkCentre 3655 Configurations

Features	3655S 3 in 1	3655X 4 in 1
Processor Speed	1 GHz - Dual Core	1 GHz - Dual Core
Memory	2 GB	2 GB
Print Speed	47 ppm, Letter 45 ppm A4	47 ppm, Letter 45 ppm, A4
PS3 Fonts (136)	Standard	Standard
PCL6 Fonts (80 Scalable, 9 Bitmap)	Standard	Standard
USB 2.0	Standard	Standard
Ethernet Interface	10/100/1000 Base-TX	10/100/1000 Base-TX
Automatic Document Feeder	Standard	Standard
Bypass Tray (150 sheet)	Standard	Standard
Tray 1 (550 sheet)	Standard	Standard
Tray 2 (550 sheet)	Optional	Optional
Tray 3 (550 sheet)	Optional	Optional
Tray 4 (550-sheet)	Optional	Optional
Duplex	Standard	Standard
Stapler	Not Available	Standard
Hard Disk Drive	Standard	Standard
Printer Stand	Optional	Optional
FAX	Not Available	Standard
Wireless LAN	Optional	Optional
Printer Resolution	600 x 600 dpi 1200 x 1200 dpi	600 x 600 dpi 1200 x 1200 dpi

2 Status Indicator RAPs

Chain 2 - User Interface

02-302-00, 02-306-00, 02-308-00 Flash Failure	2-5
02-312-00 Application Checksum Failure	2-5
02-315-00 Service Registry Bad Data.....	2-6
02-316-00, 02-317-00 SRS Error	2-6
02-320-00 Data Time Out Error	2-7
02-321-00 XEIP Browser Does Not Respond or is Dead.....	2-7
02-380-00, 02-381-00 UI Communication Fault.....	2-8
02-390-00 Configurable Services Not Stable	2-8

Chain 3 - Machine Run Control

03-306-00 Upgrade Request Failed - Downgrade Not Allowed	2-9
03-307-00 Sync Failure. Unable to Enter SW Upgrade	2-9
03-316-00 Communication Fault.....	2-10
03-317-00, 03-318-00, 03-319-00 IOT NVM Error	2-10
03-320-00 Upgrade Failed - Incompatible Product Type	2-11
03-324-00 File Transfer Failure During SW Upgrade	2-11
03-325-00 Wall Clock Fault.....	2-12
03-326-00 Upgrade Failed - Version Same as Machine	2-12
03-327-00 SW Upgrade Failed	2-13
03-329-00 Upgrade Request Failed due to Active Diagnostics	2-13
03-330-00 Upgrade Failed Security Feature Active	2-14
03-331-00, 03-332-00 Communication Fault with NC.....	2-14
03-338-00 CCM Reset	2-15
03-346-00, 03-347-00 Communication Fault with UI	2-15
03-355-00 CCM POST Failure.....	2-16
03-380-00 POST Boot Failure.....	2-16
03-390-00 Upgrade Automation Failed	2-17
03-397-00 System Configuration Error	2-17
03-398-00 SIM Card Serial Number Mismatch	2-18
03-399-00 SIM Card Data Cannot be Processed	2-18
03-401-00, 03-403-00 FAX Not Detected	2-19
03-417-00 Incompatible FAX Software Detected.....	2-19
03-777-00 Power Loss Detected.....	2-20
03-788-00 Failed to Exit Power Save Mode.....	2-20
03-790-00 Time Zone Overridden to GMT: DST Disabled.....	2-21

Chain 5 - IIT

05-110-00 DADF Pick-up Jam	2-23
05-112-00 DADF Jam During Rotation of Document.....	2-23
05-121-00 CVT-DADF Feed Sensor On Jam	2-24
05-900-00 ADF Sensor Static Jam	2-24
05-940-00 DADF No Original Fail	2-25

Chain 10 - Fuser / Exit

10-311-00 to 10-376-00 Fuser Thermal Error	2-27
10-420-00, 10-421-00 Fuser End of Life	2-27
10-902-00 Fuser Missing	2-28

10-903-00 Main Error updating data	2-28
12-930-00 Exit Tray Full.....	2-29

Chain 16 - Network Controller

16A Network Error Entry	2-31
16B FTP or SMB Unable to Connect to Remote Server	2-31
16C Remote Directory Lock Failed	2-33
16-000-00 to 16-000-26 Cannot Create RPC With ENS	2-33
16-001-09 to 16-001-90 Unable to do Startup Synchronization	2-34
16-002-09 to 16-002-46 Unable to Register as RPC Server.....	2-34
16-003-09 to 16-003-90 Too Many IPC Handles	2-35
16-004-14 to 16-005-92 RPC Failure to Register.....	2-35
16-006-09, 16-006-19 Cannot Register for Events	2-36
16-007-92 to 16-010-99 Invalid IPC / RPC Data	2-36
16-013-14, 16-014-14 Copier Synchronization Error	2-37
16-015-14, 16-015-19 SESS Data Store Variable Not Set.....	2-37
16-016-14, 16-016-19 Data Store Initialization Failed.....	2-38
16-017-19 to 16-021-26 Send Event Failure / Could Not Get Host Name RAP.....	2-38
16-021-46 Unable to Get Host Name.....	2-39
16-023-09, 16-023-26 RPC Call Failure.....	2-39
16-026-09 to 16-026-92 Memory Allocation Error	2-40
16-027-90 Unable to Obtain Well Known Queue ID.....	2-40
16-028-09, 16-028-90 Unable to Complete RPC Call / Invalid Range String.....	2-41
16-030-19 Unable to Obtain Client RPC Handle.....	2-41
16-031-09 Invalid Event Notification Received.....	2-42
16-032-19, 16-039-00 NVM Connection Failure / Pthread Create Error	2-42
16-040-92 Semaphore Fault	2-43
16-048-09 Unable to Set Binding	2-43
16-048-14, 16-048-90 Cannot Set NC Client Binding	2-44
16-048-99 Cannot Set NC Client Binding.....	2-44
16-150-09 Cannot Send Registration Event.....	2-45
16-150-14 Unable to Obtain RPC Transport	2-45
16-150-19 NC Sync Peer Service Fault	2-46
16-150-26 Fault Service Failed to Write to Log.....	2-46
16-150-90 Invalid IPC Request Destination	2-47
16-150-92 Consumer Interface Fault	2-47
16-151-09 to 16-151-19 Invalid IPC Command / SNMP Reg Failure.....	2-48
16-151-26 Fault Service Failed to Get a Log Handle.....	2-48
16-151-90 Put Environment Variable Failure	2-49
16-152-09 Internal IPC Failure	2-49
16-152-14 Empty Internal Event Received by ENS	2-50
16-152-19 Unable to Send Request to SESS	2-50
16-152-26 Fault Service Could Not Open Fault Log	2-51
16-153-09 Unable to Obtain IPC Queue	2-51
16-153-14 Cannot Initialize Internal Event List.....	2-52
16-153-19 NVM Save Failure.....	2-52
16-154-09 ESS Registration Configuration Error	2-53
16-154-14 Cannot Create Internal Event Queue.....	2-53

16-154-19 NVM Read Failure	2-54	16-619-47 Upgrade Request Failed - DMPR Failure at Web.....	2-80
16-155-19 NC Failed to Boot from Alternate Partition.....	2-54	16-620-07 to 16-620-99 Registration Service Failed.....	2-80
16-156-19 Service Run Loop Failed	2-55	16-620-47 Upgrade Request Rejected.....	2-81
16-160-09 NC Registration Service Process Death.....	2-55	16-621-00 to 16-621-99 Unable to Get Host Name	2-81
16-161-09 to 16-164-09 Cannot Send Reg Event / List Access Failure	2-56	16-622-07 to 16-622-46 Corrupt O/S RPC Table.....	2-82
16-429-00, 16-431-00 Unable to Write to Data Store / Get System Time.....	2-56	16-622-47 FTP "get" Failure.....	2-82
16-432-00 Unknown Scheduler Received.....	2-57	16-622-66 to 16-622-68 Failed to Unregister as RPC Service During Shutdown	2-83
16-433-00 RPC Call Failed	2-57	16-623-35, 16-623-47, 16-624-46 RPC Call Failure	2-83
16-434-00 Unable to Change Scheduler in DM	2-58	16-625-35 to 16-625-90 Invalid IPC Type	2-84
16-600-07 to 16-600-67 Cannot Create RPC Connection	2-58	16-626-00 to 16-626-67 Memory Allocation Error	2-84
16-601-26 to 16-601-46 Queue Setup / System Control Failed / Invalid UI Info.....	2-59	16-628-07 to 16-628-67 Range String Variable Error	2-85
16-601-47 Diag Service Failed IPC Queue Setup	2-59	16-629-11 to 16-629-93 No Acknowledgment For RPC.....	2-85
16-601-66, 16-601-67 Unable to do Start up Synchronization.....	2-60	16-630-09 to 16-630-99 Unable to Get RPC Client Handle	2-86
16-601-68 Unable to Start Up and Sync with SC.....	2-60	16-631-19 to 16-636-99 XDR Data Error	2-86
16-601-105 Unable Synchronize At Start Up	2-61	16-637-11 to 16-637-95 File Error.....	2-87
16-602-07 to 16-602-105 RPC Service Registration Failure.....	2-61	16-638-66 to 16-641-46 O/S Failure	2-87
16-603-11, 16-603-28 Replace Handler Call Failed.....	2-62	16-642-46 to 16-645-67 File I/O Errors	2-88
16-603-46 to 16-603-67 Too Many IPC Handlers	2-62	16-646-26 to 16-650-99 Invalid Service Attribute.....	2-88
16-603-68 Replace Handler Call Failed	2-63	16-651-19 to 16-656-38 Registration Failure	2-89
16-603-105, 16-604-14 RPC Call Failure to NC Registration Service	2-63	16-658-07 Unable to Get Host Name.....	2-89
16-604-38,16-604-99 Could Not Register With Reg Service	2-64	16-658-07 to 16-667-95 Parser Utility Errors	2-90
16-604-105 SESS Data Store Variable Not Set.....	2-64	16-668-47 Write NVM Failed.....	2-91
16-605-07 Unable to Register with Registration Service	2-65	16-668-93, 16-668-95 Unable To Determine Local File Statistics.....	2-91
16-605-14 to 16-605-105 RPC Registration Failure.....	2-65	16-669-28 to 16-670-00 Unable To Write Job Template.....	2-92
16-606-07 to 16-606-99 Cannot Register For Events	2-66	16-670-11 to 16-671-47 Unable To Decode Template File.....	2-92
16-606-105 OS Problem	2-66	16-671-93 to 16-673-95 File Error.....	2-93
16-607-19 to 16-608-14 Invalid RPC Data / Unable to Free Resources	2-67	16-674-00 to 16-709-00 XSA Database Error.....	2-93
16-608-26 Fault Service Failed to Unbind RAP	2-67	16-710-00 to 16-750-11 Unable To Create Client Handle.....	2-94
16-608-28 to 16-608-67 Unable to Free IPC Resources	2-68	16-750-14 to 16-750-90 Invalid Request.....	2-94
16-608-105 Build UI SVC Obtain Client Failed	2-68	16-750-92 to 16-751-26 Database Error	2-95
16-609-07 Unknown Message Received	2-69	16-751-28 to 16-751-93 Unknown Attribute	2-95
16-609-19 to 16-609-105 Invalid IPC Data Failure	2-69	16-752-00 to 16-752-47 Invalid File Details	2-96
16-610-00, 16-610-07 IPC Send Failure	2-70	16-752-66 to 16-753-28 Scan to FAX Registration Error	2-96
16-610-09 Cannot send IPC Message to NC Platform	2-70	16-753-35 to 16-754-09 Data Store Read Failure.....	2-97
16-610-11 to 16-610-90 Unable to Send IPC Message	2-71	16-754-14 to 16-754-68 OS Error	2-97
16-610-92 Failure to Send Queue Status	2-71	16-754-90 to 16-755-28 Fault Service Error.....	2-98
16-610-99 Unable to Send IPC Message RAP	2-72	16-755-35 to 16-756-14 Request Error	2-98
16-611-07, 16-611-38 Client Removal Failure	2-72	16-756-26 to 16-757-26 NVM Corrupt.....	2-99
16-611-19 to 16-611-99 Unable to Remove RPC Connection.....	2-73	16-757-35 to 16-758-26 Unable to Write NVM.....	2-99
16-612-09 to 16-612-68 Unable to Do Shutdown Sync RAP	2-73	16-758-35 to 16-759-26 Service Run Loop Failed	2-100
16-612-47 Upgrade Request Failed - Downgrade Not Allowed	2-74	16-759-46 to 16-760-46 Fail to Enable Process.....	2-100
16-613-09 to 16-614-19 DC Sync / Comms Error.....	2-74	16-760-47 to 16-761-46 File Error.....	2-101
16-614-47 Invalid Software Upgrade	2-75	16-761-47 to 16-769-95 Other Network Faults 1.....	2-101
16-615-35 to 16-615-90 SESS Data Store Variable Not Set	2-75	16-770-09 to 16-779-95 Other Network Faults 2.....	2-103
16-615-47 Multiple Software Upgrade File.....	2-76	16-780-00 to 16-789-47 Other Network Faults 3.....	2-104
16-616-35 to 16-616-46 Data Store Initialization Failure	2-76	16-790-09 to 16-799-47 Other Network Faults 4.....	2-105
16-616-47 IPC Message Failure	2-77	16-800-09 to 16-809-47 Other Network Faults 5.....	2-106
16-616-67 Submission of Email or IFax Job Failed	2-77	16-810-00 to 16-819-47 Other Network Faults 6.....	2-107
16-617-19 Send Event Failure Unable to send event to NC	2-78	16-820-47 to 16-829-47 Other Network Faults 7.....	2-108
16-617-47 Upgrade Request Failed -TAR Extraction Failure	2-78	16-830-47 to 16-839-47 Other Network Faults 8.....	2-108
16-618-47 DLM SPI Extraction Failure RAP	2-79	16-840-47 to 16-849-47 Other Network Faults 9.....	2-109
16-619-14 to 16-619-93 Unable to unregister Registration service	2-79	16-850-47 to 16-859-47 Other Network Faults 10.....	2-109

16-860-47 to 16-869-47 Other Network Faults 11	2-110	22-323-00 to 22-327-00 Service Faults	2-139
16-870-47 to 16-879-47 Other Network Faults 12	2-110	22-328-00 Incomplete System Information	2-140
16-880-47 to 16-890-47 Other Network Faults 13	2-111	22-330-00 Supplies Plan Activation Code Entry Locked.....	2-140
16-891-00, 16-892-00 Edge Server Error	2-111	22-330-01 to 22-332-00 Queue Timed Out.....	2-141
16-900-19 to 16-909-19 Other Network Faults 14	2-112	22-335-00 to 22-340-00 Service Faults.....	2-141
16-910-19 to 16-919-19 Other Network Faults 15	2-112	22-350-01, 22-350-02 Software Detects Non-Valid Xerox SOK	2-142
16-920-19 to 16-929-19 Other Network Faults 16	2-113	22-351-01 to 22-351-03 SOK Write Failure.....	2-142
16-930-19 to 16-939-19 Other Network Faults 17	2-113	22-352-00, 22-352-01 Serial Number Lost/Missing.....	2-143
16-940-19 to 16-949-19 Other Network Faults 18	2-114	22-360-00 Service Plan Inconsistent.....	2-143
16-950-19 to 16-959-19 Other Network Faults 19	2-114	22-370-00 Unable to Communicate with XSA Database	2-144
16-960-19 to 16-969-19 Other Network Faults 20	2-115	22-371-00, 22-372-00 Fax Application Registration Error.....	2-144
16-975-19 to 16-979-35 Other Network Faults 21	2-115	22-407-00 to 22-421-00 Embedded Fax Faults	2-145
16-980-00 to 16-989-35 Other Network Faults 22	2-116	22-701-04 Module Completion Fault	2-145
16-990-00 to 16-999-35 Other Network Faults 23	2-117	22-720-00, 22-721-00 Service Registry Errors.....	2-146
		22-750-04 to 22-755-17 Configuration Mismatch RAP	2-146
Chain 19 - Image Processing		Chain 42 - Drive, Cooling, and Laser Unit	
19-300-00 to 19-310-00 Image Disk (HDD) Failure	2-119	41-340-00 to 41-414-00 IOT NVM Error.....	2-147
19-401-00, 19-402-00 Out of Memory.....	2-119	41-388-00 Marking Logic Fail.....	2-147
19-403-00 Out of Memory - Job in EPC.....	2-120	42-313-00 Side Cooling Fan Failure	2-148
19-409-00 Video Integrity Fault.....	2-120	42-330-00 Fuser Exhaust Fan Fail.....	2-148
19-410-00 to 19-410-13 Image Structure Failure RAP	2-121	45-301-00 to 45-305-00 IOT I/F Error	2-149
19-750-00 EPC Memory Size Fault	2-121		
19-752-00 Image Rotation Config Fault.....	2-122	Chain 62 - Scanner	
19-754-00 Image Disk Config Fault	2-122	61-020-00 to 61-340-00 ROS Error.....	2-151
19-760-00 Test Patterns are Missing from EPC	2-123	62-311-00 to 62-389-00 IIT Scan Error	2-151
		62-316-00 DADF Motor Fail	2-152
Chain 20 - Fax		62-790-00 PreIPS XFail	2-152
20A Fax Troubleshooting Entry.....	2-125		
20B Unable To Send A Fax	2-125	Chain 70 - Media Handling	
20C Unable To Send A Fax To Some Machines	2-127	70-099-00 I/F IOTFED Communication.....	2-153
20D Unable To Receive A Fax.....	2-128	71-101-00 Tray1 Misfeed Jam	2-153
20E Fax Will Not Print	2-129	71-215-00 Tray 1 Feeder Composition Error	2-154
20F Fax Board Checkout	2-129	72-098-00 to 74-098-00 Option Feeder Mode.....	2-154
20G Fax Problems on Digital Networks	2-130	72-101-00 Tray 2 Misfeed Jam	2-155
20H Fax Tab Not Available RAP.....	2-130	72-102-00 Feeder Path 2 Sensor On Jam (RC2).....	2-155
20-302-00 to 20-305-00 Fax Board Hardware or Software Error.....	2-131	72-215-00 Tray 2 Feeder Composition Error	2-156
20-320-00 Fax Fault Not Cleared by Card Reset.....	2-131	72-216-00 Option Feeder Motor2 Error	2-156
20-322-00 NV Device Not Fitted to Basic Fax Card.....	2-132	73-101-00 Tray3 Misfeed Jam	2-157
20-323-00, 20-324-00 Fax System Memory is Low	2-132	73-102-00 Path 3 Sensor On Jam (RC3).....	2-157
20-327-00 Registers Cannot be Accessed on Extended Card	2-133	73-215-00 Tray 3 Feeder Composition Error	2-158
20-331-00 to 20-341-00 Fax Network Line 1 Fault	2-133	73-216-00 Option Feeder Motor3 Error.....	2-158
20-342-00 Error Accessing File on a NV Device.....	2-134	74-101-00 Tray 4 Misfeed Jam	2-159
20-345-00 FaxPort1 Modem Failure	2-134	74-215-00 Tray 4 Feeder Composition Error	2-159
20-701-00 Phonebook Download Failed.....	2-135	74-216-00 Option Feeder Motor4 Error.....	2-160
20-710-00, 20-711-00 Fax Card Overwrite Errors	2-135	75-101-00 Bypass Misfeed Jam.....	2-160
		77-101-00 Regi Off Jam	2-161
Chain 22 - System Errors		77-102-00 Psync On Jam.....	2-161
22-300-05 to 22-309-04 Other Network Faults 24	2-137	77-103-00, 77-104-00, 77-106-00 Exit On/Off Jam.....	2-162
22-310-04 to 22-318-04 Other Network Faults 25 RAP	2-137	77-110-00 Feeder Regi Sensor On Jam	2-162
22-319-04 IOT Integrity Problem While Printing a Job.....	2-138	77-123-00 Duplex Regi On Jam	2-163
22-320-00, 22-321-00 Scan to File Fault	2-138	77-300-00 Front Door Interlock Open	2-163
22-321-04 RS422I ResponseTimeoutError	2-139		

77-301-00 Rear Door Interlock Open.....	2-164
77-900-00 IOT Static Jam	2-164
77-901-00 Feeder Static Jam.....	2-165
Chain 95 - Software Upgrade Errors	
91-401-00, 91-402-00 K Drum Cartridge Life Near End	2-167
91-913-00 K Drum Cartridge Dead Stop Error.....	2-167
91-914-00 to 91-936-00 K Drum Cartridge Error	2-168
92-315-00 ATCFail [K]	2-168
92-584-00, 92-586-00 Internal - Over Temp Failure	2-169
92-650-00 K Image Calibration Error 1	2-169
92-661-00 Environment Temperature Sensor Fail.....	2-170
92-805-00 24V Fan Off Detect.....	2-170
93-317-00 K Drum Cartridge Dispense Fail	2-171
93-425-00, 93-912-00 K Toner Cartridge Life Near End.....	2-171
93-925-00, 93-926-00, 93-928-00 K Toner Cartridge Error	2-172
93-938-00 CRUM Validation	2-172
93-973-00 Toner CRUM [K] Not in Position	2-173
94-419-00, 94-422-00 BTR Near Life End	2-173
95-000-00 to 95-305-00 Upgrade Failure.....	2-174
95-300-00 to 95-302-00 Upgrade Failure : Incompatible Product.....	2-175
95-303-00, 95-304-00 Upgrade Failure: Downgrade / Sidegrade.....	2-176
95-305-00 Upgrade Failure: Platform Sync.....	2-176
OF - Other Faults	
OF 1 Unusual Noises	2-177
OF 2 Control Panel Touch Screen Failure	2-178
OF 3 Status Codes and Messages	2-179
OF 4 Convenience Stapler Failure	2-195
OF 5 Multi-feed Error	2-196
OF 6 Power On Self Test (POST).....	2-196

02-302-00, 02-306-00, 02-308-00 Flash Failure

02-302-00 Flash rewrite failure

02-306-00 Flash erase failure

02-308-00 Flash download failure

Procedure

WARNING

Ensure that the electricity to the machine is switched off while performing tasks that do not need electricity. Disconnect the power cord. Electricity can cause death or injury. Moving parts can cause injury.

Cycle system power. **The error persists.**

Y N
| Perform SCP 6 Final Actions.

Perform GP 9 to reload system software.

02-312-00 Application Checksum Failure

02-312-00 Application checksum failure

Procedure

WARNING

Ensure that the electricity to the machine is switched off while performing tasks that do not need electricity. Disconnect the power cord. Electricity can cause death or injury. Moving parts can cause injury.

Cycle system power. **The error persists.**

Y N
| Perform SCP 6 Final Actions.

Perform GP 9 to reload system software.

02-315-00 Service Registry Bad Data

02-315-00 Service registry bad or corrupted data

NOTE: The status code 16-503 is raised with this fault code.

Procedure

WARNING

Ensure that the electricity to the machine is switched off while performing tasks that do not need electricity. Disconnect the power cord. Electricity can cause death or injury. Moving parts can cause injury.

Cycle system power. **The error persists.**

Y N
| Perform SCP 6 Final Actions.

Perform GP 9 to reload system software.

02-316-00, 02-317-00 SRS Error

02-316-00 SRS returns to LUI invalid fields, invalid data or missing data.

02-317-00 LUI gets no response from SRS.

NOTE: The status code 16-503 is raised with these fault codes.

Procedure

WARNING

Ensure that the electricity to the machine is switched off while performing tasks that do not need electricity. Disconnect the power cord. Electricity can cause death or injury. Moving parts can cause injury.

Cycle system power. **The error persists.**

Y N
| Perform SCP 6 Final Actions.

Perform GP 9 to reload system software.

02-320-00 Data Time Out Error

02-320-00 Control Panel does not receive requested data from the CCM within the specified time limit.

NOTE: Status code 02-520 is raised with this fault code.

Procedure

WARNING

Ensure that the electricity to the machine is switched off while performing tasks that do not need electricity. Disconnect the power cord. Electricity can cause death or injury. Moving parts can cause injury.

Cycle system power. **The error persists.**

Y	N
	Perform SCP 6 Final Actions.

Perform GP 9 to reload system software.

02-321-00 XEIP Browser Does Not Respond or is Dead

02-321-00 XEIP browser does not respond or is dead

NOTE: Status code 02-521 is raised with this fault code.

Procedure

WARNING

Ensure that the electricity to the machine is switched off while performing tasks that do not need electricity. Disconnect the power cord. Electricity can cause death or injury. Moving parts can cause injury.

Cycle system power. **The error persists.**

Y	N
	Perform SCP 6 Final Actions.

Perform GP 9 to reload system software.

02-380-00, 02-381-00 UI Communication Fault

02-380-00 Communication via H-H USB net path connection between network controller and Control Panel is not working. Status code 02-501 is raised with this fault code.

02-381-00 Communication via USB connection between CC and Control Panel is not working. Status code 02-502 is raised with this fault code.

Procedure

WARNING

Ensure that the electricity to the machine is switched off while performing tasks that do not need electricity. Disconnect the power cord. Electricity can cause death or injury. Moving parts can cause injury.

CAUTION

Before a new Control Panel is installed, identify the machine software level. Check the compatibility of the software on the new user interface assembly. Install the software to meet the customer machine requirements.

Cycle system power. **The error persists.**

Y N
| Perform SCP 6 Final Actions

Check connections between the ESS Board and Control Panel, REP 1.2.1. **The connections are secure.**

Y N
| Secure the connections.

Install new components as necessary:

- Control Panel, PL 1.2 Item 1
- ESS Board, PL 18.1 Item 98

02-390-00 Configurable Services Not Stable

02-390-00 During power up, not all configurable services achieved a stable state after 5 minutes. Status code 02-590 is raised with this fault code.

Procedure

WARNING

Ensure that the electricity to the machine is switched off while performing tasks that do not need electricity. Disconnect the power cord. Electricity can cause death or injury. Moving parts can cause injury.

Cycle system power. **The error persists.**

Y N
| Perform SCP 6 Final Actions.

Perform GP 9 to reload system software.

03-306-00 Upgrade Request Failed - Downgrade Not Allowed

03-306-00 Downgrade of system software not allowed

The reload process is aborted and the printer resets. If configured, an email alert is sent and upgrade report printed. An entry is made in Upgrade History log.

Procedure

WARNING

Ensure that the electricity to the machine is switched off while performing tasks that do not need electricity. Disconnect the power cord. Electricity can cause death or injury. Moving parts can cause injury.

Obtain a current system software set, then perform GP 9 to reload system software. **The error persists.**

Y N
| Perform SCP 6 Final Actions.

Perform GP 9 to reload system software.

03-307-00 Sync Failure. Unable to Enter SW Upgrade

03-307-00 Software upgrade synchronization failure

The reload process does not start and the printer resets. If configured, an email alert is sent and upgrade report printed. An entry is made in Upgrade History log.

Procedure

WARNING

Ensure that the electricity to the machine is switched off while performing tasks that do not need electricity. Disconnect the power cord. Electricity can cause death or injury. Moving parts can cause injury.

Obtain a current system software set, then perform GP 9 to reload system software. **The error persists.**

Y N
| Perform SCP 6 Final Actions.

Perform GP 9 to reload system software.

03-316-00 Communication Fault

03-316-00 CCM cannot communicate with IOT. Communications have failed. An automatic reset is initiated 1 time. Status codes 03-561 and 03-505 are raised with this fault code.

Initial Actions

- If the fault occurs during a software upgrade, wait 15 minutes for the software programming operation to complete, before performing the next action.
- Check fault history for other 03-xxx faults. If 03-xxx fault codes occur randomly, the cause may be electrical noise.

Procedure

WARNING

Ensure that the electricity to the machine is switched off while performing tasks that do not need electricity. Disconnect the power cord. Electricity can cause death or injury. Moving parts can cause injury.

Cycle system power. **The error persists.**

Y N
| Perform SCP 6 Final Actions.

Check connections between the IIT and IOT at the IP, IIT Control, and MCU Boards. **The connections are secure.**

Y N
| Secure the connections.

Perform GP 9 to reload system software. **The error persists.**

Y N
| Perform SCP 6 Final Actions.

Install new components as necessary:

- ESS Board, REP 18.1.98
- IIT Control Board, REP 18.1.4
- MCU Board, REP 18.2.2

03-317-00, 03-318-00, 03-319-00 IOT NVM Error

03-317-00 Error saving critical IOT NVM

03-318-00 Error initializing IOT NVM

03-319-00 Error restoring critical IOT NVM

Procedure

WARNING

Ensure that the electricity to the machine is switched off while performing tasks that do not need electricity. Disconnect the power cord. Electricity can cause death or injury. Moving parts can cause injury.

Obtain a current system software set, then perform GP 9 to reload system software. **The error persists.**

Y N
| Perform SCP 6 Final Actions.

Perform GP 9 to reload system software. **The error persists.**

Y N
| Perform SCP 6 Final Actions.

Install new components as necessary:

- ESS Board, REP 18.1.98
- MCU Board, REP 18.2.2

03-320-00 Upgrade Failed - Incompatible Product Type

03-320-00 Incompatible Product Type

Software upgrade aborted due to incompatible product type. System software set does not match the product hardware.

Procedure

WARNING

Ensure that the electricity to the machine is switched off while performing tasks that do not need electricity. Disconnect the power cord. Electricity can cause death or injury. Moving parts can cause injury.

Check the version number installed and obtain the correct system software set. Perform GP 9 to reload system software. **The error persists.**

Y N
| Perform SCP 6 Final Actions.

Retry system software reload. **The error persists.**

Y N
| Perform SCP 6 Final Actions.

Install new components as necessary:

- ESS Board, REP 18.1.98
- IIT Control Board, REP 18.1.4
- MCU Board, REP 18.2.2

03-324-00 File Transfer Failure During SW Upgrade

03-324-00 SW Upgrade File Transfer Failure

Software upgrade aborted due to file transfer failure. The upgrade process is aborted and the printer resets. If configured, an email alert is sent and upgrade report printed. An entry is made in Upgrade History log.

Procedure

WARNING

Ensure that the electricity to the machine is switched off while performing tasks that do not need electricity. Disconnect the power cord. Electricity can cause death or injury. Moving parts can cause injury.

Download a new system software set for the product, then perform GP 9 to reload system software. **The error persists.**

Y N
| Perform SCP 6 Final Actions.

Retry the system software reload from a different USB port. **The error persists.**

Y N
| Perform SCP 6 Final Actions.

Install new components as necessary:

- ESS Board, REP 18.1.98
- MCU Board, REP 18.2.2

03-325-00 Wall Clock Fault

03-325-00 System clock did not increment within the specified time limit. The operating system detected the system clock failed to increment within 1.5 seconds during power on. Status code 03-505 is raised with this fault code.

NOTE: *The printer may boot with this fault, but printing may be disabled.*

Initial Actions

WARNING

Ensure that the electricity to the machine is switched off while performing tasks that do not need electricity. Disconnect the power cord. Electricity can cause death or injury. Moving parts can cause injury.

Check fault history for other 03-xxx fault codes. If 03-xxx fault codes occur randomly, the cause may be electrical noise.

Procedure

Cycle system power. **The error persists.**

Y N
| Perform SCP 6 Final Actions

Perform GP 9 to reload system software. **The error persists.**

Y N
| Perform SCP 6 Final Actions

Check battery installation on the ESS Board. **The error persists.**

Y N
| Perform SCP 6 Final Actions

Install new components as necessary:

- ESS Board, REP 18.1.98

03-326-00 Upgrade Failed - Version Same as Machine

03-320-00 Upgrade is not required

Software upgrade is not required, identical system software set is already on the printer. The upgrade process is aborted and the printer resets. If configured, an email alert is sent and upgrade report printed. An entry is made in Upgrade History log.

Procedure

WARNING

Ensure that the electricity to the machine is switched off while performing tasks that do not need electricity. Disconnect the power cord. Electricity can cause death or injury. Moving parts can cause injury.

Check the version number installed and obtain the correct system software set. Perform GP 9 to reload system software. **The error persists.**

Y N
| Perform SCP 6 Final Actions.

Perform GP 9 to reload system software.

03-327-00 SW Upgrade Failed

03-327-00 Upgrade failure

Software upgrade has failed. The upgrade process is aborted and the printer resets. If configured and possible, an email alert is sent and upgrade report printed. An entry is made in Upgrade History log.

Procedure

WARNING

Ensure that the electricity to the machine is switched off while performing tasks that do not need electricity. Disconnect the power cord. Electricity can cause death or injury. Moving parts can cause injury.

Obtain a current system software set, then perform GP 9 to reload system software. **The error persists.**

Y N
| Perform SCP 6 Final Actions.

Perform GP 9 to reload system software.

03-329-00 Upgrade Request Failed due to Active Diagnostics

03-329-00 Upgrade failure due to active diagnostics

Software upgrade request during active diagnostics. The upgrade process is aborted and the printer resets. If configured, an email alert is sent and upgrade report printed. An entry is made in Upgrade History log.

Procedure

WARNING

Ensure that the electricity to the machine is switched off while performing tasks that do not need electricity. Disconnect the power cord. Electricity can cause death or injury. Moving parts can cause injury.

Perform GP 9 to reload system software. **The error persists.**

Y N
| Perform SCP 6 Final Actions.

Perform GP 9 to reload system software.

03-330-00 Upgrade Failed Security Feature Active

03-329-00 Upgrade failure due to active security feature

Software upgrade request during while a security feature is active. The upgrade process is aborted and the printer resets. If configured, an email alert is sent and upgrade report printed. An entry is made in Upgrade History log.

Procedure

WARNING

Ensure that the electricity to the machine is switched off while performing tasks that do not need electricity. Disconnect the power cord. Electricity can cause death or injury. Moving parts can cause injury.

Perform GP 9 to reload system software. **The error persists.**

Y N
| Perform SCP 6 Final Actions.

Perform GP 9 to reload system software.

03-331-00, 03-332-00 Communication Fault with NC

03-331-00 Main controller board cannot communicate with network controller. Status code 03-563 is raised with this fault code.

03-332-00 Unable to reestablish communications with the network controller after 12 minutes. Status code 03-518 is raised with this fault code.

Initial Actions

Check fault history for other 03-xxx fault codes. If 03-xxx fault codes occur randomly, the cause may be electrical noise.

Procedure

WARNING

Ensure that the electricity to the machine is switched off while performing tasks that do not need electricity. Disconnect the power cord. Electricity can cause death or injury. Moving parts can cause injury.

Cycle system power. **The error persists.**

Y N
| Perform SCP 6 Final Actions.

Perform GP 9 to reload system software. **The error persists.**

Y N
| Perform SCP 6 Final Actions.

Install new components as necessary:

- ESS Board, REP 18.1.98

03-338-00 CCM Reset

03-338-00 The main controller on CCM reset because either the watch dog timer timed out or because the application SW wrote to an illegal address.

Initial Actions

Check fault history for other 03-xxx fault codes. If 03-xxx fault codes occur randomly, the cause may be electrical noise.

Procedure

WARNING

Ensure that the electricity to the machine is switched off while performing tasks that do not need electricity. Disconnect the power cord. Electricity can cause death or injury. Moving parts can cause injury.

Cycle system power. **The error persists.**

Y N
| Perform SCP 6 Final Actions

Perform GP 9 to reload system software. **The error persists.**

Y N
| Perform SCP 6 Final Actions

Install new components as necessary:

- ESS Board, REP 18.1.98

03-346-00, 03-347-00 Communication Fault with UI

03-346-00 Unable to reestablish communication with the Control Panel after 30 seconds. Status code 03-520 is raised with the fault code.

03-347-00 ESS Board cannot communicate with the Control Panel. Continue to attempt to establish communication for 30 seconds. Status code 03-521 is raised with the fault code.

NOTE: Network printing remains operational.

Initial Actions

Check fault history for other 03-xxx fault codes. If 03-xxx fault codes occur randomly, the cause may be electrical noise.

Procedure

WARNING

Ensure that the electricity to the machine is switched off while performing tasks that do not need electricity. Disconnect the power cord. Electricity can cause death or injury. Moving parts can cause injury.

Cycle system power. **The error persists.**

Y N
| Perform SCP 6 Final Actions

Perform GP 9 to reload system software. **The error persists.**

Y N
| Perform SCP 6 Final Actions

Install new components as necessary:

- ESS Board, REP 18.1.98
- Control Panel, REP 1.2.1

03-355-00 CCM POST Failure

03-338-00 CCM POST failure. NVM battery may be dead.

Initial Actions

Check SD Card and ESS Board battery installation.

Procedure

WARNING

Ensure that the electricity to the machine is switched off while performing tasks that do not need electricity. Disconnect the power cord. Electricity can cause death or injury. Moving parts can cause injury.

Cycle system power. **The error persists.**

Y N
| Perform SCP 6 Final Actions

Install new components as necessary:

- ESS Board, REP 18.1.98

03-380-00 POST Boot Failure

03-380-00 POST boot failure. Fault assumes no Control Panel communications.

NOTE: PWS communication for diagnostic purposes available.

Initial Actions

Check fault history for other 03-xxx fault codes. If 03-xxx fault codes occur randomly, the cause may be electrical noise.

Procedure

WARNING

Ensure that the electricity to the machine is switched off while performing tasks that do not need electricity. Disconnect the power cord. Electricity can cause death or injury. Moving parts can cause injury.

Cycle system power. **The error persists.**

Y N
| Perform SCP 6 Final Actions

Perform GP 9 to reload system software. **The error persists.**

Y N
| Perform SCP 6 Final Actions

Install new components as necessary:

- ESS Board, REP 18.1.98
- Control Panel, REP 1.2.1

03-390-00 Upgrade Automation Failed

03-390-00 Automatic upgrade process failure.

Initial Actions

Check fault history for other 03-xxx fault codes. If 03-xxx fault codes occur randomly, the cause may be electrical noise.

Procedure

WARNING

Ensure that the electricity to the machine is switched off while performing tasks that do not need electricity. Disconnect the power cord. Electricity can cause death or injury. Moving parts can cause injury.

Cycle system power. **The error persists.**

Y	N
	Perform SCP 6 Final Actions

Perform GP 9 to reload system software. **The error persists.**

Y	N
	Perform SCP 6 Final Actions

Install new components as necessary:

- ESS Board, REP 18.1.98
- Control Panel, REP 1.2.1

03-397-00 System Configuration Error

03-390-00 System Configuration Error

Initial Actions

Check fault history for other 03-xxx fault codes. If 03-xxx fault codes occur randomly, the cause may be electrical noise.

Procedure

WARNING

Ensure that the electricity to the machine is switched off while performing tasks that do not need electricity. Disconnect the power cord. Electricity can cause death or injury. Moving parts can cause injury.

Cycle system power. **The error persists.**

Y	N
	Perform SCP 6 Final Actions

Perform GP 9 to reload system software. **The error persists.**

Y	N
	Perform SCP 6 Final Actions

Install new components as necessary:

- SD Card, REP 18.1.96
- ESS Board, REP 18.1.98

03-398-00 SIM Card Serial Number Mismatch

03-398-00 SIM card serial number did not match the serial number contained in system CCS NVM. Status code 22-559 is raised with this fault code.

NOTE: Printing is disabled by this fault.

Initial Actions

Check fault history for other 03-xxx fault codes. If 03-xxx fault codes occur randomly, the cause may be electrical noise.

Procedure

WARNING

Ensure that the electricity to the machine is switched off while performing tasks that do not need electricity. Disconnect the power cord. Electricity can cause death or injury. Moving parts can cause injury.

Cycle system power. **The error persists.**

Y	N
	Perform SCP 6 Final Actions

Perform GP 9 to reload system software. **The error persists.**

Y	N
	Perform SCP 6 Final Actions

Install new components as necessary:

- SD Card, REP 18.1.96
- ESS Board, REP 18.1.98

03-399-00 SIM Card Data Cannot be Processed

03-399-00 Unable to establish communications with the SIM Card. Status code 22-560 is raised with this fault code.

NOTE: Printing is disabled by this fault.

Initial Actions

Check fault history for other 03-xxx fault codes. If 03-xxx fault codes occur randomly, the cause may be electrical noise.

Procedure

WARNING

Ensure that the electricity to the machine is switched off while performing tasks that do not need electricity. Disconnect the power cord. Electricity can cause death or injury. Moving parts can cause injury.

Cycle system power. **The error persists.**

Y	N
	Perform SCP 6 Final Actions

Perform GP 9 to reload system software. **The error persists.**

Y	N
	Perform SCP 6 Final Actions

Install new components as necessary:

- SD Card, REP 18.1.96
- ESS Board, REP 18.1.98

03-401-00, 03-403-00 FAX Not Detected

03-401-00 Basic FAX not detected/confirmed. Status code 03-547 is raised with this fault code.

03-403-00 Extended FAX not detected/confirmed. Status code 03-548 is raised with this fault code.

Initial Actions

Check fault history for other 03-xxx fault codes. If 03-xxx fault codes occur randomly, the cause may be electrical noise.

Procedure

WARNING

Ensure that the electricity to the machine is switched off while performing tasks that do not need electricity. Disconnect the power cord. Electricity can cause death or injury. Moving parts can cause injury.

Check FAX Board connections. **The error persists.**

Y	N
	Perform SCP 6 Final Actions

Cycle system power. **The error persists.**

Y	N
	Perform SCP 6 Final Actions

Perform GP 9 to reload system software. **The error persists.**

Y	N
	Perform SCP 6 Final Actions

Install new components as necessary:

- FAX Board, REP 18.1.7
- ESS Board, REP 18.1.98

03-417-00 Incompatible FAX Software Detected

03-417-00 FAX software version supplied at power up is not compatible with the CCM. Status code 03-546 is raised with this fault code.

Initial Actions

Check fault history for other 03-xxx fault codes. If 03-xxx fault codes occur randomly, the cause may be electrical noise.

Procedure

WARNING

Ensure that the electricity to the machine is switched off while performing tasks that do not need electricity. Disconnect the power cord. Electricity can cause death or injury. Moving parts can cause injury.

Perform GP 9 to reload system software. **The error persists.**

Y	N
	Perform SCP 6 Final Actions

Install new components as necessary:

- FAX Board, REP 18.1.7
- ESS Board, REP 18.1.98

03-777-00 Power Loss Detected

03-777-00 The printer detected an AC power loss.

Initial Actions

- Connect the printer directly to a dedicated AC outlet.
- Check fault history for other 03-xxx fault codes. If 03-xxx fault codes occur randomly, the cause may be electrical noise.

Procedure

WARNING

Ensure that the electricity to the machine is switched off while performing tasks that do not need electricity. Disconnect the power cord. Electricity can cause death or injury. Moving parts can cause injury.

Check AC Inlet connections. **The error persists.**

Y N
| Perform SCP 6 Final Actions

Install new components as necessary:

- AC Inlet Harness, REP 18.4.99
- ESS Board, REP 18.1.98

03-788-00 Failed to Exit Power Save Mode

03-788-00 Failed to exit power save mode

NOTE: Status code 03-598 is raised with this fault code.

Procedure

WARNING

Ensure that the electricity to the machine is switched off while performing tasks that do not need electricity. Disconnect the power cord. Electricity can cause death or injury. Moving parts can cause injury.

Cycle system power. **The error persists.**

Y N
| Perform SCP 6 Final Actions

Perform GP 9 to reload system software.

03-790-00 Time Zone Overridden to GMT: DST Disabled

03-790-00 Time Zone overridden to GMT: DST Disabled. Contact the system admin to reset.

Procedure

WARNING

Ensure that the electricity to the machine is switched off while performing tasks that do not need electricity. Disconnect the power cord. Electricity can cause death or injury. Moving parts can cause injury.

Cycle system power. **The error persists.**

Y N

Perform SCP 6 Final Actions

Perform GP 9 to reload system software.

05-110-00 DADF Pick-up Jam

05-110-00 DADF pick-up jam. DADF registration sensor does not detect the media leading edge in the specified time from feed start.

Initial Actions

- Remove all documents from the DADF.
- Make sure that the customer is not using damaged documents.
- Clean the DADF registration sensor and surrounding area.
- Check that the Pick-up Assembly is installed correctly, REP 21.1.97.

Procedure

WARNING

Ensure that the electricity to the machine is switched off while performing tasks that do not need electricity. Disconnect the power cord. Electricity can cause death or injury. Moving parts can cause injury.

NOTE: To access the DADF registration sensor, remove the DADF Top Cover, REP 21.1.98.

Open the DADF Top Cover and clean the area surrounding the DADF Pick-up Assembly. **The error persists.**

Y	N
	Perform SCP 6 Final Actions.

Clean or replace the DADF Pick-up Assembly, REP 21.1.97. **The error persists.**

Y	N
	Perform SCP 6 Final Actions.

Install new components as necessary:

- DADF Pick-up Assembly, REP 21.1.97
- DADF Assembly, REP 21.1.1
- IIT Control Board, REP 18.1.4

05-112-00 DADF Jam During Rotation of Document

05-112-00 DADF jam during rotation of document. DADF registration sensor does not detect the media leading edge in the specified time from feed start.

Initial Actions

- Remove all documents from the DADF.
- Make sure that the customer is not using damaged documents.
- Clean the DADF registration sensor and surrounding area.
- Check that the Pick-up Assembly is installed correctly, REP 21.1.97.

Procedure

WARNING

Ensure that the electricity to the machine is switched off while performing tasks that do not need electricity. Disconnect the power cord. Electricity can cause death or injury. Moving parts can cause injury.

NOTE: To access the DADF registration sensor, remove the DADF Top Cover, REP 21.1.98.

Open the DADF Top Cover and clean the area surrounding the DADF Pick-up Assembly. **The error persists.**

Y	N
	Perform SCP 6 Final Actions.

Clean or replace the DADF Pick-up Assembly, REP 21.1.97. **The error persists.**

Y	N
	Perform SCP 6 Final Actions.

Install new components as necessary:

- DADF Pick-up Assembly, REP 21.1.97
- DADF Assembly, REP 21.1.1
- IIT Control Board, REP 18.1.4

05-121-00 CVT-DADF Feed Sensor On Jam

05-121-00 The feed sensor is not turned on in the time specified. In Duplex mode, the feed sensor is not turned on after a specified time.

Initial Actions

- Remove all documents from the DADF.
- Make sure that the customer is not using damaged documents.
- Clean the DADF registration sensor and surrounding area.
- Check that the Pick-up Assembly is installed correctly, REP 21.1.97.

Procedure

WARNING

Ensure that the electricity to the machine is switched off while performing tasks that do not need electricity. Disconnect the power cord. Electricity can cause death or injury. Moving parts can cause injury.

NOTE: To access the DADF registration sensor, remove the DADF Top Cover, REP 21.1.98.

Open the DADF Top Cover and clean the area surrounding the DADF Pick-up Assembly. **The error persists.**

Y N
| Perform SCP 6 Final Actions.

Clean or replace the DADF Pick-up Assembly, REP 21.1.97. **The error persists.**

Y N
| Perform SCP 6 Final Actions.

Install new components as necessary:

- DADF Pick-up Assembly, REP 21.1.97
- DADF Assembly, REP 21.1.1
- IIT Control Board, REP 18.1.4

05-900-00 ADF Sensor Static Jam

05-900-00 The DADF Top Cover interlock switch is opened during DADF operation. Paper remains in paper path after cover is closed..

Initial Actions

- Remove all documents from the DADF.
- Make sure that the Top Cover closes correctly.
- Check the switch actuator on the DADF Top Cover. If the actuator is damaged, install a new DADF Top Cover, REP 21.1.98.

Procedure

WARNING

Ensure that the electricity to the machine is switched off while performing tasks that do not need electricity. Disconnect the power cord. Electricity can cause death or injury. Moving parts can cause injury.

Check the DADF Top Cover properly actuates the interlock switch. **The error persists.**

Y N
| Perform SCP 6 Final Actions.

Replace the DADF Assembly, REP 21.1.1.

05-940-00 DADF No Original Fail

05-940-00 Original has been removed. Status code 05-535 is raised with this fault code.

Initial Actions

- Remove all documents from the DADF.
- Clean the DADF registration sensor and surrounding area.
- Check that the Pick-up Assembly is installed correctly, REP 21.1.97.

Procedure

WARNING

Ensure that the electricity to the machine is switched off while performing tasks that do not need electricity. Disconnect the power cord. Electricity can cause death or injury. Moving parts can cause injury.

NOTE: To access the DADF registration sensor, remove the DADF Top Cover, REP 21.1.98.

Open the DADF Top Cover and clean the area surrounding the DADF Pick-up Assembly. **The error persists.**

Y N
| Perform SCP 6 Final Actions.

Clean or replace the DADF Pick-up Assembly, REP 21.1.97. **The error persists.**

Y N
| Perform SCP 6 Final Actions.

Install new components as necessary:

- DADF Pick-up Assembly, REP 21.1.97
- DADF Assembly, REP 21.1.1
- IIT Control Board, REP 18.1.4

10-311-00 to 10-376-00 Fuser Thermal Error

10-311-00 Center STS sensor burnout detection

10-321-00 Hard Relay OFF

10-324-00 Sub lamp ON consecutive errors

10-326-00 Cool Down Timeout

10-328-00 Warming up - timeout

10-334-00 STS center-side sensor failure

10-337-00 Heat Roll Paper twine Error

10-338-00 Main lamp ON consecutive errors

10-372-00 Center STS High-temperature anomaly

10-373-00 Side STS Disconnection abnormality

10-374-00 Side STS High-temperature anomaly

10-375-00 Center STS Low-temperature anomaly

10-376-00 Side STS Low-temperature anomaly

NOTE: Status codes 03-561 and 10-527 are raised with this fault code.

Procedure

WARNING

Switch off the electricity to the machine. Disconnect the power cord from the customer supply while performing tasks that do not need electricity. Electricity can cause death or injury. Moving parts can cause injury.

WARNING

Do not touch the Fuser while it is hot.

Cycle system power. **The error persists.**

Y N
| Go to SCP 6 and complete the Final Actions.

Replace the Fuser, REP 7.1.1

10-420-00, 10-421-00 Fuser End of Life

10-420-00 Fuser Assy Near Life. Status code 10-524 is raised with this fault code.

10-421-00 Fuser Assy Life End. Status code 10-523 is raised with this fault code.

Procedure

WARNING

Switch off the electricity to the machine. Disconnect the power cord from the customer supply while performing tasks that do not need electricity. Electricity can cause death or injury. Moving parts can cause injury.

WARNING

Do not touch the Fuser while it is hot.

Check the Fuser life count. **Fuser life count is at or near end of life.**

Y N
| Cycle system power. **The error message is displayed.**

Y N
| Reassemble and perform SCP 6 Final Actions.

Replace the Fuser, REP 7.1.1.

Replace the Fuser, REP 7.1.1.

10-902-00 Fuser Missing

10-902-00 Fuser missing

NOTE: Status code 09-639 is raised with this fault code.

Procedure

WARNING

Switch off the electricity to the machine. Disconnect the power cord from the customer supply while performing tasks that do not need electricity. Electricity can cause death or injury. Moving parts can cause injury.

WARNING

Do not touch the Fuser while it is hot.

Reseat the Fuser. **The error persists.**

Y N
| Go to SCP 6 and complete the Final Actions.

Replace the Fuser, REP 7.1.1.

10-903-00 Main Error updating data

10-902-00 Main Error updating data

NOTE: Status codes 03-561 and 10-527 are raised with this fault code.

Procedure

WARNING

Switch off the electricity to the machine. Disconnect the power cord from the customer supply while performing tasks that do not need electricity. Electricity can cause death or injury. Moving parts can cause injury.

WARNING

Do not touch the Fuser while it is hot.

Cycle system power. **The error persists.**

Y N
| Go to SCP 6 and complete the Final Actions.

Replace the Fuser, REP 7.1.1.

12-930-00 Exit Tray Full

12-930-00 Exit Tray Full

NOTE: Status code 12-730 is raised with this fault code.

Initial Actions

- Empty the output tray.
- Check the full stack acuator for damage or obstructed movement.

Procedure

WARNING

Switch off the electricity to the machine. Disconnect the power cord from the customer supply while performing tasks that do not need electricity. Electricity can cause death or injury. Moving parts can cause injury.

WARNING

Do not touch the Fuser while it is hot.

Cycle system power. **The error persists.**

Y N

Go to SCP 6 and complete the Final Actions.

Use dC330 code 71-122 to check Full Stack Sensor operation. **The sensor signal changes.**

Y N

Remove the Exit Chute Assembly to check the sensor, acuator, and harness. **The sensor is connected and the harness undamaged.**

Y N

Replace the Full Stack Sensor or repair the harness. If the actuator is damaged, replace the Exit Chute Assembly.

Replace the MCU Board, REP 18.2.2

Install new components as necessary:

- Full Stack Sensor, REP 17.1.9
- Exit Chute Assembly, REP 17.1.99
- MCU Board, REP 18.2.2

16A Network Error Entry

Use this RAP when the customer reports network failures. e.g. Cannot connect to the scan server when using FTP or SMB protocols, or when a folder on the scan server cannot be opened.

NOTE: The fault message appears on the confirmation report. The report may take several minutes to print after scanning the document.

Initial Actions

Consult your manager before troubleshooting the customer's network, as the policy varies according to region.

Procedure

NOTE: If it is possible to log into CWIS by entering the printer's IP address, then the network controller on the ESS Board is good.

Perform the following:

1. Check that the printer date and time are correctly set.
2. Print a Configuration page.
3. Check that confirmation report printing is enabled. If necessary, ask the customer to enable printing of the confirmation report.
4. Ensure that the printer is configured for scan to file:
 - a. Check the back of the configuration report under the heading Workflow Scanning.
 - b. If a IP address or name is not listed next to Alt1 Repository Protocol, ask the customer to configure the machine before continuing.
5. Go to the relevant procedure:
 - 16B FTP or SMB Unable to Connect to Remote Server RAP.
 - 16C Remote Directory Lock Failed RAP.

16B FTP or SMB Unable to Connect to Remote Server

The printer cannot connect, find or login to the scan server.

Procedure

NOTE: The FTP/SMB protocol is followed by a colon and port number, :21 for FTP and :139 for SMB.

Scan the document using the default template and one other template. **The fault is present on both templates.**

Y N

The failed template is incorrectly configured. Ask the customer or system administrator to verify the settings of the web template that failed, including the login password.

Ask the customer to open the printer's CWIS page. **The printer's CWIS page opens.**

Y N

Look at the front of the Configuration report. Make sure HTTP is enabled and set to port 80. **The settings are correct.**

Y N

Enable HTTP and set the port to 80. Restart this RAP from the beginning. If this path has been followed previously, escalate the fault to the system administrator. If the customer does not have a system administrator, they should contact the Customer Support Center or request a Xerox analyst troubleshoot their network which is subject to a charge.

Disconnect the network cable from the printer. Make sure the PWS network adaptor settings are set to Auto. Use a crossover cable to connect the PWS to the printer. **Either the two LEDs on the ESS Board or PWS are lit, indicating a connection.**

Y N

Perform the following:

1. Change the network speed setting of the machine.
2. If the LEDs light, use the new network speed setting. Inform the customer that the network speed has been changed then follow the Yes path from this step.
3. If the LEDs do not light, install a new ESS Board, REP 18.1.98.

Correctly configure the PWS IP address to communicate with the printer, refer to Set a Static IP Address on the PWS. Make sure to disable the PWS firewall. Ping the printer from the PWS.

NOTE: Re-enable the PWS firewall after completion of this procedure.

The printer responds to the ping request.

Y N

Perform an Altboot, GP 9.

The printer software is up to date.

Y N

Upgrade the software, GP 9. **The fault persists.**

Y N

Perform SCP 6 Final Actions.

Perform the Customers Settings Check. **Customer settings were changed.**

A B

Y N
Escalate the fault to the system administrator. If the customer does not have a system administrator, they should contact the Customer Support Center or request a Xerox analyst troubleshoot their network which will be subject to a charge.

Retry the job. **The job was successful.**

Y N
Escalate the fault to the system administrator. If the customer does not have a system administrator, they should contact the Customer Support Center or request a Xerox analyst troubleshoot their network which will be subject to a charge.

Perform SCP 6 Final Actions.

Perform the Customers Settings Check. **Customer settings were changed.**

Y N
Escalate the fault to the system administrator. If the customer does not have a system administrator, they should contact the Customer Support Center or request a Xerox analyst troubleshoot their network which will be subject to a charge.

Retry the job. **The job was successful.**

Y N
Escalate the fault to the system administrator. If the customer does not have a system administrator, they should contact the Customer Support Center or request a Xerox analyst troubleshoot their network which will be subject to a charge.

Perform SCP 6 Final Actions.

Ask the customer to ping the scan servers IP address or name.

NOTE: The scan server is the computer the job is being sent to. The scan server's IP address or name appears on the confirmation report.

The customer can ping the scan server.

Y N
Check the configuration report for default gateway IP address listed under TCP/IPv6 Settings. **A default gateway IP address is listed.**

Y N
Perform the Customers Settings Check. **Customer settings were changed.**

Y N
Escalate the fault to the system administrator. If the customer does not have a system administrator, they should contact the Customer Support Center or request a Xerox analyst troubleshoot their network which will be subject to a charge.

Retry the job. **The job was successful.**

Y N
Escalate the fault to the system administrator. If the customer does not have a system administrator, they should contact the Customer Support Center or request a Xerox analyst troubleshoot their network which will be subject to a charge.

C D E

Perform SCP 6 Final Actions.

The customer can ping the default gateway IP address.

Y N
Escalate the fault to the system administrator. If the customer does not have a system administrator, they should contact the Customer Support Center or request a Xerox analyst troubleshoot their network which will be subject to a charge.

Perform the Customers Settings Check. **Customer settings were changed.**

Y N
Escalate the fault to the system administrator. If the customer does not have a system administrator, they should contact the Customer Support Center or request a Xerox analyst troubleshoot their network which will be subject to a charge.

Retry the job. **The job was successful.**

Y N
Escalate the fault to the system administrator. If the customer does not have a system administrator, they should contact the Customer Support Center or request a Xerox analyst troubleshoot their network which will be subject to a charge.

Perform SCP 6 Final Actions.

Perform the Customers Settings Check. **Customer settings were changed.**

Y N
Escalate the fault to the system administrator. If the customer does not have a system administrator, they should contact the Customer Support Center or request a Xerox analyst troubleshoot their network which will be subject to a charge.

Retry the job. **The job was successful.**

Y N
Escalate the fault to the system administrator. If the customer does not have a system administrator, they should contact the Customer Support Center or request a Xerox analyst troubleshoot their network which will be subject to a charge.

Perform SCP 6 Final Actions.

Customers Settings Check

NOTE: Both the configuration and confirmation reports are required to check the customers settings. Corrections must be made through the printer's CWIS page.

Check the following with the customer, ask the customer to correct any errors:

1. The scan server is online.
NOTE: The scan server is the computer that the job is being sent.
2. The scan server's IP address or name is correct.
3. The path and user name are correct.
4. The Share name is correct, referred too as the Volume on the configuration report (**SMB protocol only**).
5. Check that the correct password has been entered on the printer's CWIS page.

NOTE: The password is not printed on the configuration or confirmation reports.

16C Remote Directory Lock Failed

Use this RAP when the customer reports that the machine has logged onto the scan server, but cannot create a folder inside of the scan directory. The creation of the scan folder is necessary for the machine to successfully complete the can to file job.

NOTE: *The scan server is the computer that the job is being sent.*

Procedure

The machines login name that it is using to log onto the scan server, for this file repository, does not have sufficient rights. Ask the customer to verify the rights for this user at the scan server, or escalate the problem to their system administrator. If the customer does not have a System Administrator, they should contact the Customer Support Centre or request a Xerox analyst troubleshoot their network which will be subject to a charge.

16-000-00 to 16-000-26 Cannot Create RPC With ENS

16-000-00 Format Service Non Shutdown NC Faults

16-000-01 ENS Service Non Shutdown NC Faults

16-000-09 Cannot create RPC connection with ENS

16-000-14 Cannot create RPC connection with ENS

16-000-19 Cannot create RPC connection with ENS

16-000-26 Cannot create RPC connection with ENS

NOTE: *Status codes 03-518 and 16-502 are raised with these fault codes.*

Procedure

WARNING

Ensure that the electricity to the machine is switched off while performing tasks that do not need electricity. Disconnect the power cord. Electricity can cause death or injury. Moving parts can cause injury.

If a single occurrence, the network controller automatically retries. **The error persists.**

Y N
| Perform SCP 6 Final Actions.

Perform GP 9 to reload system software.

16-001-09 to 16-001-90 Unable to do Startup Synchronization

16-001-09 Unable to do startup synchronization

16-001-14 Unable to do startup synchronization

16-001-19 Unable to do startup synchronization

16-001-26 Unable to Start up and synchronize with SC

16-001-47 Unable to do startup synchronization

16-001-90 Unable to do startup synchronization

NOTE: Status codes 03-518 and 16-502 are raised with these fault codes.

Procedure

WARNING

Ensure that the electricity to the machine is switched off while performing tasks that do not need electricity. Disconnect the power cord. Electricity can cause death or injury. Moving parts can cause injury.

If a single occurrence, the network controller automatically retries. **The error persists.**

Y N
| Perform SCP 6 Final Actions.

Cycle system power. **The error persists.**

Y N
| Perform SCP 6 Final Actions.

Perform GP 9 to reload system software.

16-002-09 to 16-002-46 Unable to Register as RPC Server

16-002-09 Unable to Register as RPC server

16-002-14 Unable to Register as RPC server

16-002-19 Unable to Register as an RPC server

16-002-26 Could not become an RPC Server

16-002-46 Unable to Register as an RPC server

NOTE: Status codes 03-518 and 16-502 are raised with these fault codes.

Procedure

WARNING

Ensure that the electricity to the machine is switched off while performing tasks that do not need electricity. Disconnect the power cord. Electricity can cause death or injury. Moving parts can cause injury.

If a single occurrence, the network controller automatically retries. **The error persists.**

Y N
| Perform SCP 6 Final Actions.

Cycle system power. **The error persists.**

Y N
| Perform SCP 6 Final Actions.

Perform GP 9 to reload system software.

16-003-09 to 16-003-90 Too Many IPC Handles

16-003-09 Too many IPC Handles

16-003-14 Too many IPC Handles

16-003-19 Too many IPC Handlers

16-003-90 Utility Insert Handler Failure

NOTE: Status codes 03-518 and 16-502 are raised with these fault codes.

Procedure

WARNING

Ensure that the electricity to the machine is switched off while performing tasks that do not need electricity. Disconnect the power cord. Electricity can cause death or injury. Moving parts can cause injury.

If a single occurrence, the network controller automatically retries. **The error persists.**

Y N
| Perform SCP 6 Final Actions.

Cycle system power. **The error persists.**

Y N
| Perform SCP 6 Final Actions.

Perform GP 9 to reload system software.

16-004-14 to 16-005-92 RPC Failure to Register

16-004-14 RPC Connect Failure to NC Registration Service

16-004-19 RPC Connect Failure to NC Registration Service

16-004-26 RPC Connect Failure to NC Registration Service

16-004-46 RPC Failed to Connect to with NC Service

16-005-14 RPC Call Failure to NC Registration Service

16-005-19 RPC Call Failure to NC Registration Service

16-005-26 RPC Call Failure to NC Registration Service

16-005-46 RPC Failed to Register with NC Service

16-005-68 RPC Failed to Register with NC Service

16-005-90 RPC call to NC Registration Failed

16-005-92 RPC Failed to Register with NC Service

NOTE: Status codes 03-518 and 16-502 are raised with these fault codes.

Procedure

WARNING

Ensure that the electricity to the machine is switched off while performing tasks that do not need electricity. Disconnect the power cord. Electricity can cause death or injury. Moving parts can cause injury.

If a single occurrence, the network controller automatically retries. **The error persists.**

Y N
| Perform SCP 6 Final Actions.

Cycle system power. **The error persists.**

Y N
| Perform SCP 6 Final Actions.

Perform GP 9 to reload system software.

16-006-09, 16-006-19 Cannot Register for Events

16-006-09 Cannot register for events

16-006-19 Cannot register for events

NOTE: Status codes 03-518 and 16-502 are raised with these fault codes.

Procedure

WARNING

Ensure that the electricity to the machine is switched off while performing tasks that do not need electricity. Disconnect the power cord. Electricity can cause death or injury. Moving parts can cause injury.

Cycle system power. **The error persists.**

Y N
| Perform SCP 6 Final Actions.

Perform GP 9 to reload system software.

16-007-92 to 16-010-99 Invalid IPC / RPC Data

16-007-92 Invalid RPC Data Received

16-009-09 Invalid IPC Data Received

16-010-14 Unable to send IPC

16-010-99 Unable to send IPC

Procedure

WARNING

Ensure that the electricity to the machine is switched off while performing tasks that do not need electricity. Disconnect the power cord. Electricity can cause death or injury. Moving parts can cause injury.

If a single occurrence, the network controller automatically retries. **The error persists.**

Y N
| Perform SCP 6 Final Actions.

Cycle system power. **The error persists.**

Y N
| Perform SCP 6 Final Actions.

Perform GP 9 to reload system software.

16-013-14, 16-014-14 Copier Synchronization Error

16-013-14 Digital Copier ENS synchronization error

16-014-14 Digital Copier ENS registration error

NOTE: Status codes 03-518 and 16-502 are raised with these fault codes.

Procedure

WARNING

Ensure that the electricity to the machine is switched off while performing tasks that do not need electricity. Disconnect the power cord. Electricity can cause death or injury. Moving parts can cause injury.

Cycle system power. **The error persists.**

Y	N
	Perform SCP 6 Final Actions.

Perform GP 9 to reload system software.

16-015-14, 16-015-19 SESS Data Store Variable Not Set

16-015-14 SESS data store environmental variable not set

16-015-19 SESS data store environmental variable not set

NOTE: Status codes 03-518 and 16-502 are raised with these fault codes.

Procedure

WARNING

Ensure that the electricity to the machine is switched off while performing tasks that do not need electricity. Disconnect the power cord. Electricity can cause death or injury. Moving parts can cause injury.

Cycle system power. **The error persists.**

Y	N
	Perform SCP 6 Final Actions.

Perform GP 9 to reload system software.

16-016-14, 16-016-19 Data Store Initialization Failed

16-016-14 Data store initialization failed

16-016-19 Data store initialization failed

NOTE: Status codes 03-518 and 16-502 are raised with these fault codes.

Procedure

WARNING

Ensure that the electricity to the machine is switched off while performing tasks that do not need electricity. Disconnect the power cord. Electricity can cause death or injury. Moving parts can cause injury.

Cycle system power. **The error persists.**

Y N
| Perform SCP 6 Final Actions.

Perform GP 9 to reload system software.

16-017-19 to 16-021-26 Send Event Failure / Could Not Get Host Name RAP

16-017-19 Send Event Failure Unable to send event to NC ENS

16-021-19 NC PM Registration Connect Error

16-021-26 Service could not get Host Name

NOTE: Status codes 03-518 and 16-502 are raised with these fault codes.

Procedure

WARNING

Ensure that the electricity to the machine is switched off while performing tasks that do not need electricity. Disconnect the power cord. Electricity can cause death or injury. Moving parts can cause injury.

If a single occurrence, the network controller automatically retries. **The error persists.**

Y N
| Perform SCP 6 Final Actions.

Cycle system power. **The error persists.**

Y N
| Perform SCP 6 Final Actions.

Perform GP 9 to reload system software.

16-021-46 Unable to Get Host Name

16-021-46 Unable to get Host Name

NOTE: Status codes 03-518 and 16-502 are raised with this fault code.

Procedure

WARNING

Ensure that the electricity to the machine is switched off while performing tasks that do not need electricity. Disconnect the power cord. Electricity can cause death or injury. Moving parts can cause injury.

If a single instance occurs, cycle system power. **The error persists.**

Y N
| Perform SCP 6 Final Actions.

Perform GP 9 to reload system software.

16-023-09, 16-023-26 RPC Call Failure

16-023-09 RPC Call Failure to ENS

16-023-26 RPC Call Failure to ENS

NOTE: Status codes 03-518 and 16-502 are raised with these fault codes.

Procedure

WARNING

Ensure that the electricity to the machine is switched off while performing tasks that do not need electricity. Disconnect the power cord. Electricity can cause death or injury. Moving parts can cause injury.

If a single occurrence, the network controller automatically retries. **The error persists.**

Y N
| Perform SCP 6 Final Actions.

Cycle system power. **The error persists.**

Y N
| Perform SCP 6 Final Actions.

Perform GP 9 to reload system software.

16-026-09 to 16-026-92 Memory Allocation Error

16-026-09 Memory Allocation Failure

16-026-14 Malloc Error

16-026-46 Memory Allocation Error

16-026-90 Malloc Error

16-026-92 Memory Allocation Fault

NOTE: Status codes 03-518 and 16-502 are raised with these fault codes.

Procedure

WARNING

Ensure that the electricity to the machine is switched off while performing tasks that do not need electricity. Disconnect the power cord. Electricity can cause death or injury. Moving parts can cause injury.

If a single occurrence, the network controller automatically retries. **The error persists.**

Y N
| Perform SCP 6 Final Actions.

Cycle system power. **The error persists.**

Y N
| Perform SCP 6 Final Actions.

Perform GP 9 to reload system software.

16-027-90 Unable to Obtain Well Known Queue ID

16-027-90 Unable to obtain well known queue ID

NOTE: Status codes 03-518 and 16-502 are raised with this fault code.

Procedure

WARNING

Ensure that the electricity to the machine is switched off while performing tasks that do not need electricity. Disconnect the power cord. Electricity can cause death or injury. Moving parts can cause injury.

If a single occurrence, the network controller automatically retries. **The error persists.**

Y N
| Perform SCP 6 Final Actions.

Cycle system power. **The error persists.**

Y N
| Perform SCP 6 Final Actions.

Perform GP 9 to reload system software.

16-028-09, 16-028-90 Unable to Complete RPC Call / Invalid Range String

16-028-09 Unable to complete RPC call

16-028-90 Invalid Range String

NOTE: Status codes 03-518 and 16-502 are raised with this fault code.

Procedure

WARNING

Ensure that the electricity to the machine is switched off while performing tasks that do not need electricity. Disconnect the power cord. Electricity can cause death or injury. Moving parts can cause injury.

If a single occurrence, the network controller automatically retries. **The error persists.**

Y N
| Perform SCP 6 Final Actions.

Cycle system power. **The error persists.**

Y N
| Perform SCP 6 Final Actions.

Perform GP 9 to reload system software.

16-030-19 Unable to Obtain Client RPC Handle

16-030-19 Unable to obtain client RPC handle to EJS

NOTE: Status codes 03-518 and 16-502 are raised with this fault code.

Procedure

WARNING

Ensure that the electricity to the machine is switched off while performing tasks that do not need electricity. Disconnect the power cord. Electricity can cause death or injury. Moving parts can cause injury.

If a single occurrence, the network controller automatically retries. **The error persists.**

Y N
| Perform SCP 6 Final Actions.

Cycle system power. **The error persists.**

Y N
| Perform SCP 6 Final Actions.

Perform GP 9 to reload system software.

16-031-09 Invalid Event Notification Received

16-031-09 Invalid event notification received

NOTE: Status codes 03-518 and 16-502 are raised with this fault code.

Procedure

WARNING

Ensure that the electricity to the machine is switched off while performing tasks that do not need electricity. Disconnect the power cord. Electricity can cause death or injury. Moving parts can cause injury.

If a single occurrence, the network controller automatically retries. **The error persists.**

Y N
| Perform SCP 6 Final Actions.

Cycle system power. **The error persists.**

Y N
| Perform SCP 6 Final Actions.

Perform GP 9 to reload system software.

16-032-19, 16-039-00 NVM Connection Failure / Pthread Create Error

16-032-19 NVM Connection Failure

16-039-00 Pthread Create Error

NOTE: Status codes 03-518 and 16-502 are raised with these fault codes.

Procedure

WARNING

Ensure that the electricity to the machine is switched off while performing tasks that do not need electricity. Disconnect the power cord. Electricity can cause death or injury. Moving parts can cause injury.

If a single occurrence, the network controller automatically retries. **The error persists.**

Y N
| Perform SCP 6 Final Actions.

Cycle system power. **The error persists.**

Y N
| Perform SCP 6 Final Actions.

Perform GP 9 to reload system software.

16-040-92 Semaphore Fault

16-040-92 Semaphore fault

NOTE: Status codes 03-518 and 16-502 are raised with this fault code.

Procedure

WARNING

Ensure that the electricity to the machine is switched off while performing tasks that do not need electricity. Disconnect the power cord. Electricity can cause death or injury. Moving parts can cause injury.

Cycle system power. **The error persists.**

Y N
| Perform SCP 6 Final Actions.

Perform GP 9 to reload system software.

16-048-09 Unable to Set Binding

16-048-09 Unable to set binding

NOTE: Status codes 03-518 and 16-502 are raised with this fault code.

Procedure

WARNING

Ensure that the electricity to the machine is switched off while performing tasks that do not need electricity. Disconnect the power cord. Electricity can cause death or injury. Moving parts can cause injury.

If a single occurrence, the network controller automatically retries. **The error persists.**

Y N
| Perform SCP 6 Final Actions.

Cycle system power. **The error persists.**

Y N
| Perform SCP 6 Final Actions.

Perform GP 9 to reload system software.

16-048-14, 16-048-90 Cannot Set NC Client Binding

16-048-14 Cannot set NC client binding

16-048-90 Cannot set NC client binding

Procedure

WARNING

Ensure that the electricity to the machine is switched off while performing tasks that do not need electricity. Disconnect the power cord. Electricity can cause death or injury. Moving parts can cause injury.

Cycle system power. **The error persists.**

Y N
| Perform SCP 6 Final Actions.

Perform GP 9 to reload system software.

16-048-99 Cannot Set NC Client Binding

16-048-99 Unable to set client binding

Procedure

WARNING

Ensure that the electricity to the machine is switched off while performing tasks that do not need electricity. Disconnect the power cord. Electricity can cause death or injury. Moving parts can cause injury.

If a single occurrence, the network controller automatically retries. **The error persists.**

Y N
| Perform SCP 6 Final Actions.

Cycle system power. **The error persists.**

Y N
| Perform SCP 6 Final Actions.

Perform GP 9 to reload system software.

16-150-09 Cannot Send Registration Event

16-150-09 Cannot send Registration Event

NOTE: Status codes 03-518 and 16-502 are raised with this fault code.

Procedure

WARNING

Ensure that the electricity to the machine is switched off while performing tasks that do not need electricity. Disconnect the power cord. Electricity can cause death or injury. Moving parts can cause injury.

Cycle system power. **The error persists.**

Y N
| Perform SCP 6 Final Actions.

Perform GP 9 to reload system software.

16-150-14 Unable to Obtain RPC Transport

16-150-14 Unable to obtain RPC transport

NOTE: Status codes 03-518 and 16-502 are raised with this fault code.

Procedure

WARNING

Ensure that the electricity to the machine is switched off while performing tasks that do not need electricity. Disconnect the power cord. Electricity can cause death or injury. Moving parts can cause injury.

If a single occurrence, the network controller automatically retries. **The error persists.**

Y N
| Perform SCP 6 Final Actions.

Cycle system power. **The error persists.**

Y N
| Perform SCP 6 Final Actions.

Perform GP 9 to reload system software.

16-150-19 NC Sync Peer Service Fault

16-150-19 Unable to sync peer infrastructure services. Operating system tries 3 times; If fault continues, the ESS is reset.

Procedure

WARNING

Ensure that the electricity to the machine is switched off while performing tasks that do not need electricity. Disconnect the power cord. Electricity can cause death or injury. Moving parts can cause injury.

Cycle system power. **The error persists.**

Y N
| Perform SCP 6 Final Actions.

Perform GP 9 to reload system software.

16-150-26 Fault Service Failed to Write to Log

16-150-26 Fault Service Failed to write to log

Procedure

WARNING

Ensure that the electricity to the machine is switched off while performing tasks that do not need electricity. Disconnect the power cord. Electricity can cause death or injury. Moving parts can cause injury.

Cycle system power. **The error persists.**

Y N
| Perform SCP 6 Final Actions.

Perform GP 9 to reload system software.

16-150-90 Invalid IPC Request Destination

16-150-90 Invalid IPC request destination

NOTE: Status codes 03-518 and 16-502 are raised with this fault code.

Procedure

WARNING

Ensure that the electricity to the machine is switched off while performing tasks that do not need electricity. Disconnect the power cord. Electricity can cause death or injury. Moving parts can cause injury.

If a single occurrence, the network controller automatically retries. **The error persists.**

Y N
| Perform SCP 6 Final Actions.

Cycle system power. **The error persists.**

Y N
| Perform SCP 6 Final Actions.

Perform GP 9 to reload system software.

16-150-92 Consumer Interface Fault

16-150-92 Consumer interface fault

NOTE: Status codes 03-518 and 16-502 are raised with this fault code.

Procedure

WARNING

Ensure that the electricity to the machine is switched off while performing tasks that do not need electricity. Disconnect the power cord. Electricity can cause death or injury. Moving parts can cause injury.

Cycle system power. **The error persists.**

Y N
| Perform SCP 6 Final Actions.

Perform GP 9 to reload system software.

16-151-09 to 16-151-19 Invalid IPC Command / SNMP Reg Failure

16-151-09 Invalid IPC command

16-151-14 SNMP event registration failed

16-151-19 Invalid IPC command

NOTE: Status codes 03-518 and 16-502 are raised with these fault codes.

Procedure

WARNING

Ensure that the electricity to the machine is switched off while performing tasks that do not need electricity. Disconnect the power cord. Electricity can cause death or injury. Moving parts can cause injury.

If a single occurrence, the network controller automatically retries. **The error persists.**

Y N
| Perform SCP 6 Final Actions.

Cycle system power. **The error persists.**

Y N
| Perform SCP 6 Final Actions.

Perform GP 9 to reload system software.

16-151-26 Fault Service Failed to Get a Log Handle

16-151-26 Fault service failed to get a log handle

Procedure

WARNING

Ensure that the electricity to the machine is switched off while performing tasks that do not need electricity. Disconnect the power cord. Electricity can cause death or injury. Moving parts can cause injury.

Cycle system power. **The error persists.**

Y N
| Perform SCP 6 Final Actions.

Perform GP 9 to reload system software.

16-151-90 Put Environment Variable Failure

16-151-90 Put environment variable failure

NOTE: Status codes 03-518 and 16-502 are raised with this fault code.

Procedure

WARNING

Ensure that the electricity to the machine is switched off while performing tasks that do not need electricity. Disconnect the power cord. Electricity can cause death or injury. Moving parts can cause injury.

Cycle system power. **The error persists.**

Y N
| Perform SCP 6 Final Actions.

Perform GP 9 to reload system software.

16-152-09 Internal IPC Failure

16-152-09 Internal IPC failure

NOTE: Status codes 03-518 and 16-502 are raised with this fault code.

Procedure

WARNING

Ensure that the electricity to the machine is switched off while performing tasks that do not need electricity. Disconnect the power cord. Electricity can cause death or injury. Moving parts can cause injury.

If a single occurrence, the network controller automatically retries. **The error persists.**

Y N
| Perform SCP 6 Final Actions.

Cycle system power. **The error persists.**

Y N
| Perform SCP 6 Final Actions.

Perform GP 9 to reload system software.

16-152-14 Empty Internal Event Received by ENS

16-152-14 Empty internal event received by ENS

NOTE: Status codes 03-518 and 16-502 are raised with this fault code.

Procedure

WARNING

Ensure that the electricity to the machine is switched off while performing tasks that do not need electricity. Disconnect the power cord. Electricity can cause death or injury. Moving parts can cause injury.

If a single occurrence, the network controller automatically retries. **The error persists.**

Y N
| Perform SCP 6 Final Actions.

Cycle system power. **The error persists.**

Y N
| Perform SCP 6 Final Actions.

Perform GP 9 to reload system software.

16-152-19 Unable to Send Request to SESS

16-152-19 Unable to send request to SESS

NOTE: Status codes 03-518 and 16-502 are raised with this fault code.

Procedure

WARNING

Ensure that the electricity to the machine is switched off while performing tasks that do not need electricity. Disconnect the power cord. Electricity can cause death or injury. Moving parts can cause injury.

If a single occurrence, the network controller automatically retries. **The error persists.**

Y N
| Perform SCP 6 Final Actions.

Cycle system power. **The error persists.**

Y N
| Perform SCP 6 Final Actions.

Perform GP 9 to reload system software.

16-152-26 Fault Service Could Not Open Fault Log

16-152-26 Fault Service could not open Fault Log

Procedure

WARNING

Ensure that the electricity to the machine is switched off while performing tasks that do not need electricity. Disconnect the power cord. Electricity can cause death or injury. Moving parts can cause injury.

If a single occurrence, perform GP 9 to reload system software. **The error persists.**

Y N
| Perform SCP 6 Final Actions.

Check the Hard Drive harness connections. **The error persists.**

Y N
| Perform SCP 6 Final Actions.

Install a new Hard Drive.

16-153-09 Unable to Obtain IPC Queue

16-153-09 Unable to obtain IPC queue

NOTE: Status codes 03-518 and 16-502 are raised with this fault code.

Procedure

WARNING

Ensure that the electricity to the machine is switched off while performing tasks that do not need electricity. Disconnect the power cord. Electricity can cause death or injury. Moving parts can cause injury.

If a single occurrence, the network controller automatically retries. **The error persists.**

Y N
| Perform SCP 6 Final Actions.

Cycle system power. **The error persists.**

Y N
| Perform SCP 6 Final Actions.

Perform GP 9 to reload system software.

16-153-14 Cannot Initialize Internal Event List

16-153-14 Cannot initialize internal event list

Procedure

WARNING

Ensure that the electricity to the machine is switched off while performing tasks that do not need electricity. Disconnect the power cord. Electricity can cause death or injury. **Moving parts can cause injury.**

If a single occurrence, the network controller automatically retries. **The error persists.**

Y N
| Perform SCP 6 Final Actions.

Cycle system power. **The error persists.**

Y N
| Perform SCP 6 Final Actions.

Perform GP 9 to reload system software.

16-153-19 NVM Save Failure

16-153-19 NVM Save Failure

Procedure

WARNING

Ensure that the electricity to the machine is switched off while performing tasks that do not need electricity. Disconnect the power cord. Electricity can cause death or injury. **Moving parts can cause injury.**

Cycle system power. **The error persists.**

Y N
| Perform SCP 6 Final Actions.

Perform GP 9 to reload system software. **The error persists.**

Y N
| Perform SCP 6 Final Actions

Install new components as necessary:

- ESS Board, REP 18.1.98

16-154-09 ESS Registration Configuration Error

16-154-09 ESS Registration service configuration error

Procedure

WARNING

Ensure that the electricity to the machine is switched off while performing tasks that do not need electricity. Disconnect the power cord. Electricity can cause death or injury. Moving parts can cause injury.

If a single occurrence, perform GP 9 to reload system software. **The error persists.**

Y N
| Perform SCP 6 Final Actions.

Verify system software version, download a new version and install.

16-154-14 Cannot Create Internal Event Queue

16-154-14 Cannot create internal event queue

Procedure

WARNING

Ensure that the electricity to the machine is switched off while performing tasks that do not need electricity. Disconnect the power cord. Electricity can cause death or injury. Moving parts can cause injury.

Cycle system power. **The error persists.**

Y N
| Perform SCP 6 Final Actions.

Perform GP 9 to reload system software.

16-154-19 NVM Read Failure

16-154-19 NVM read failure

NOTE: Status codes 03-518 and 16-502 are raised with this fault code.

Procedure

WARNING

Ensure that the electricity to the machine is switched off while performing tasks that do not need electricity. Disconnect the power cord. Electricity can cause death or injury. Moving parts can cause injury.

Cycle system power. **The error persists.**

Y N
| Perform SCP 6 Final Actions.

Perform GP 9 to reload system software. **The error persists.**

Y N
| Perform SCP 6 Final Actions

Install new components as necessary:

- ESS Board, REP 18.1.98

16-155-19 NC Failed to Boot from Alternate Partition

16-155-19 NC Failed to Boot from Alternate Disk Partition

Procedure

WARNING

Ensure that the electricity to the machine is switched off while performing tasks that do not need electricity. Disconnect the power cord. Electricity can cause death or injury. Moving parts can cause injury.

Cycle system power. **The error persists.**

Y N
| Perform SCP 6 Final Actions.

Perform GP 9 to reload system software.

16-156-19 Service Run Loop Failed

16-156-19 Service run loop failed

NOTE: Status code 16-575 is raised with this fault code.

Procedure

WARNING

Ensure that the electricity to the machine is switched off while performing tasks that do not need electricity. Disconnect the power cord. Electricity can cause death or injury. Moving parts can cause injury.

Cycle system power. **The error persists.**

Y N
| Perform SCP 6 Final Actions.

Perform GP 9 to reload system software.

16-160-09 NC Registration Service Process Death

16-160-09 ESS Registration Service Process Death

NOTE: Status code 16-575 is raised with this fault code.

Procedure

WARNING

Ensure that the electricity to the machine is switched off while performing tasks that do not need electricity. Disconnect the power cord. Electricity can cause death or injury. Moving parts can cause injury.

If a single occurrence, the network controller automatically retries. **The error persists.**

Y N
| Perform SCP 6 Final Actions.

Cycle system power. **The error persists.**

Y N
| Perform SCP 6 Final Actions.

Check fault history log for possible root cause. This error is a symptom of another problem.

16-161-09 to 16-164-09 Cannot Send Reg Event / List Access Failure

16-161-09 Cannot send registration event

NOTE: Status code 16-576 is raised with this fault code.

16-162-09 NC Platform Manager Service Process Death

NOTE: Status code 16-577 is raised with this fault code.

16-163-09 NC DM Agent Service Process Death

NOTE: Status code 16-584 is raised with this fault code.

16-164-09 List access failure (create, add, find, delete)

Procedure

WARNING

Ensure that the electricity to the machine is switched off while performing tasks that do not need electricity. Disconnect the power cord. Electricity can cause death or injury. Moving parts can cause injury.

If a single occurrence, the network controller automatically retries. **The error persists.**

Y N
| Perform SCP 6 Final Actions.

Cycle system power. **The error persists.**

Y N
| Perform SCP 6 Final Actions.

Check fault history log for possible root cause. These errors are symptoms of other problems.

16-429-00, 16-431-00 Unable to Write to Data Store / Get System Time

16-429-00 Unable to write to data store

16-431-00 Unable to get system time

Procedure

WARNING

Ensure that the electricity to the machine is switched off while performing tasks that do not need electricity. Disconnect the power cord. Electricity can cause death or injury. Moving parts can cause injury.

Cycle system power. **The error persists.**

Y N
| Perform SCP 6 Final Actions.

Perform GP 9 to reload system software.

16-432-00 Unknown Scheduler Received

16-432-00 Unknown scheduler received

Procedure

WARNING

Ensure that the electricity to the machine is switched off while performing tasks that do not need electricity. Disconnect the power cord. Electricity can cause death or injury. **Moving parts can cause injury.**

Cycle system power. **The error persists.**

Y N

| Perform SCP 6 Final Actions.

Perform GP 9 to reload system software.

16-433-00 RPC Call Failed

16-433-00 RPC call failed

Procedure

WARNING

Ensure that the electricity to the machine is switched off while performing tasks that do not need electricity. Disconnect the power cord. Electricity can cause death or injury. **Moving parts can cause injury.**

If a single occurrence, the network controller automatically retries. **The error persists.**

Y N

| Perform SCP 6 Final Actions.

Cycle system power. **The error persists.**

Y N

| Perform SCP 6 Final Actions.

Perform GP 9 to reload system software.

16-434-00 Unable to Change Scheduler in DM

16-434-00 Unable to change scheduler received

Procedure

WARNING

Ensure that the electricity to the machine is switched off while performing tasks that do not need electricity. Disconnect the power cord. Electricity can cause death or injury. Moving parts can cause injury.

Cycle system power. **The error persists.**

Y N
| Perform SCP 6 Final Actions.

Perform GP 9 to reload system software.

16-600-07 to 16-600-67 Cannot Create RPC Connection

16-600-07 Cannot create RPC connection to ENS

16-600-35 Cannot create RPC connection to ENS

16-600-46 Cannot create RPC connection to ENS

16-600-66 Unable to create RPC connection to ENS

16-600-67 Unable to create RPC connection to ENS

Procedure

WARNING

Ensure that the electricity to the machine is switched off while performing tasks that do not need electricity. Disconnect the power cord. Electricity can cause death or injury. Moving parts can cause injury.

If a single occurrence, the network controller automatically retries. **The error persists.**

Y N
| Perform SCP 6 Final Actions.

Cycle system power. **The error persists.**

Y N
| Perform SCP 6 Final Actions.

Perform GP 9 to reload system software.

16-601-26 to 16-601-46 Queue Setup / System Control Failed / Invalid UI Info

16-601-26 Fault Service Failed IPC Queue Setup

16-601-35 System control initialization Failed

16-601-46 Invalid UI Information (RPC data) Returned

Procedure

WARNING

Ensure that the electricity to the machine is switched off while performing tasks that do not need electricity. Disconnect the power cord. Electricity can cause death or injury. Moving parts can cause injury.

If a single occurrence, the network controller automatically retries. **The error persists.**

Y N
| Perform SCP 6 Final Actions.

Cycle system power. **The error persists.**

Y N
| Perform SCP 6 Final Actions.

Perform GP 9 to reload system software.

16-601-47 Diag Service Failed IPC Queue Setup

16-601-47 Diagnostics service failed IPC queue setup

Procedure

WARNING

Ensure that the electricity to the machine is switched off while performing tasks that do not need electricity. Disconnect the power cord. Electricity can cause death or injury. Moving parts can cause injury.

Cycle system power. **The error persists.**

Y N
| Perform SCP 6 Final Actions.

Perform GP 9 to reload system software.

16-601-66, 16-601-67 Unable to do Start up Synchronization

16-601-66 Unable to do start up synchronization

16-601-67 Unable to do start up synchronization

Procedure

WARNING

Ensure that the electricity to the machine is switched off while performing tasks that do not need electricity. Disconnect the power cord. Electricity can cause death or injury. Moving parts can cause injury.

Cycle system power. The error persists.

Y N
| Perform SCP 6 Final Actions.

Perform GP 9 to reload system software.

16-601-68 Unable to Start Up and Sync with SC

16-601-68 Unable to start up & synchronize with SC

Procedure

WARNING

Ensure that the electricity to the machine is switched off while performing tasks that do not need electricity. Disconnect the power cord. Electricity can cause death or injury. Moving parts can cause injury.

Cycle system power. The error persists.

Y N
| Perform SCP 6 Final Actions.

Perform GP 9 to reload system software.

16-601-105 Unable Synchronize At Start Up

16-601-105 Unable to do start up synchronization

Procedure

WARNING

Ensure that the electricity to the machine is switched off while performing tasks that do not need electricity. Disconnect the power cord. Electricity can cause death or injury. Moving parts can cause injury.

Cycle system power. **The error persists.**

Y N
| Perform SCP 6 Final Actions.

Perform GP 9 to reload system software.

16-602-07 to 16-602-105 RPC Service Registration Failure

16-602-07 RPC Service Registration Failure

16-602-09 Unable to unregister as RPC service

16-602-11 RPC Server Registration failed

16-602-28 RPC Server Registration failed

16-602-35 RPC Server Registration

16-602-38 RPC Server Registration Failed

16-602-66 Unable to Register as an RPC Server

16-602-67 Unable to Register as an RPC Server

16-602-68 Unable to Register as an RPC Server

16-602-105 Unable to Register as an RPC Server

Procedure

WARNING

Ensure that the electricity to the machine is switched off while performing tasks that do not need electricity. Disconnect the power cord. Electricity can cause death or injury. Moving parts can cause injury.

If a single occurrence, the network controller automatically retries. **The error persists.**

Y N
| Perform SCP 6 Final Actions.

Cycle system power. **The error persists.**

Y N
| Perform SCP 6 Final Actions.

Perform GP 9 to reload system software.

16-603-11, 16-603-28 Replace Handler Call Failed

16-603-11 Replace Handler call failed

16-603-28 Replace Handler call failed

Procedure

WARNING

Ensure that the electricity to the machine is switched off while performing tasks that do not need electricity. Disconnect the power cord. Electricity can cause death or injury. Moving parts can cause injury.

Cycle system power. **The error persists.**

Y N
| Perform SCP 6 Final Actions.

Perform GP 9 to reload system software.

16-603-46 to 16-603-67 Too Many IPC Handlers

16-603-46 Too many IPC handlers

16-603-66 Too many IPC handlers

16-603-67 Too many IPC handlers

Procedure

WARNING

Ensure that the electricity to the machine is switched off while performing tasks that do not need electricity. Disconnect the power cord. Electricity can cause death or injury. Moving parts can cause injury.

If a single occurrence, the network controller automatically retries. **The error persists.**

Y N
| Perform SCP 6 Final Actions.

Cycle system power. **The error persists.**

Y N
| Perform SCP 6 Final Actions.

Perform GP 9 to reload system software.

16-603-68 Replace Handler Call Failed

16-603-68 Replace handler call failed

Procedure

WARNING

Ensure that the electricity to the machine is switched off while performing tasks that do not need electricity. Disconnect the power cord. Electricity can cause death or injury. Moving parts can cause injury.

Cycle system power. **The error persists.**

Y N
| Perform SCP 6 Final Actions.

Perform GP 9 to reload system software.

16-603-105, 16-604-14 RPC Call Failure to NC Registration Service

16-603-105 RPC call failure to network controller registration service.

16-604-14 RPC call failure to network controller registration service

Procedure

WARNING

Ensure that the electricity to the machine is switched off while performing tasks that do not need electricity. Disconnect the power cord. Electricity can cause death or injury. Moving parts can cause injury.

If a single occurrence, the network controller automatically retries. **The error persists.**

Y N
| Perform SCP 6 Final Actions.

Cycle system power. **The error persists.**

Y N
| Perform SCP 6 Final Actions.

Perform GP 9 to reload system software.

16-604-38,16-604-99 Could Not Register With Reg Service

16-604-38 Could not register with registration service

16-604-99 Could not register with registration service

Procedure

WARNING

Ensure that the electricity to the machine is switched off while performing tasks that do not need electricity. Disconnect the power cord. Electricity can cause death or injury. Moving parts can cause injury.

Cycle system power. **The error persists.**

Y N
| Perform SCP 6 Final Actions.

Perform GP 9 to reload system software.

16-604-105 SESS Data Store Variable Not Set

16-604-105 SESS data store environmental variable not set

Procedure

WARNING

Ensure that the electricity to the machine is switched off while performing tasks that do not need electricity. Disconnect the power cord. Electricity can cause death or injury. Moving parts can cause injury.

Cycle system power. **The error persists.**

Y N
| Perform SCP 6 Final Actions.
| Perform GP 9 to reload system software.

16-605-07 Unable to Register with Registration Service

16-605-07 Unable to register with registration service

Procedure

WARNING

Ensure that the electricity to the machine is switched off while performing tasks that do not need electricity. Disconnect the power cord. Electricity can cause death or injury. Moving parts can cause injury.

Cycle system power. **The error persists.**

Y N
| Perform SCP 6 Final Actions.

Perform GP 9 to reload system software.

16-605-14 to 16-605-105 RPC Registration Failure

16-605-14 RPC call failure to ESS registration service

16-605-26 Fault Service timed out

16-605-35 RPC Call Failure to NC Registration Service

16-605-47 RPC Call Failure to NC Registration Service

16-605-66 RPC Call Failure to NC Registration Service

16-605-67 RPC Call Failure to NC Registration Service

16-605-105 Unable to unregister as RPC service during shutdown

Procedure

WARNING

Ensure that the electricity to the machine is switched off while performing tasks that do not need electricity. Disconnect the power cord. Electricity can cause death or injury. Moving parts can cause injury.

If a single occurrence, the network controller automatically retries. **The error persists.**

Y N
| Perform SCP 6 Final Actions.

Cycle system power. **The error persists.**

Y N
| Perform SCP 6 Final Actions.

Perform GP 9 to reload system software.

16-606-07 to 16-606-99 Cannot Register For Events

16-606-07 Cannot register for events

16-606-35 Cannot register for events

16-606-46 Cannot register for events

16-606-99 Cannot register for events

Procedure

WARNING

Ensure that the electricity to the machine is switched off while performing tasks that do not need electricity. Disconnect the power cord. Electricity can cause death or injury. Moving parts can cause injury.

Cycle system power. The error persists.

Y N

| Perform SCP 6 Final Actions.

Perform GP 9 to reload system software.

16-606-105 OS Problem

16-606-105 OS problem

Procedure

WARNING

Ensure that the electricity to the machine is switched off while performing tasks that do not need electricity. Disconnect the power cord. Electricity can cause death or injury. Moving parts can cause injury.

Cycle system power. The error persists.

Y N

| Perform SCP 6 Final Actions.

Perform GP 9 to reload system software.

16-607-19 to 16-608-14 Invalid RPC Data / Unable to Free Resources

16-607-19 Invalid RPC data received

16-607-46 Invalid RPC data received

16-607-47 Invalid RPC disk diagnostic data received

16-607-92 Invalid RPC data received

16-607-105 Service run loop failed

16-608-09 Unable to free IPC resources

16-608-11 IPC unregister failed

16-608-14 Unable to free IPC resources

Procedure

WARNING

Ensure that the electricity to the machine is switched off while performing tasks that do not need electricity. Disconnect the power cord. Electricity can cause death or injury. Moving parts can cause injury.

If a single occurrence, the network controller automatically retries. **The error persists.**

Y N
| Perform SCP 6 Final Actions.

Cycle system power. **The error persists.**

Y N
| Perform SCP 6 Final Actions.

Perform GP 9 to reload system software.

16-608-26 Fault Service Failed to Unbind RAP

16-608-26 Fault service failed to unbind with SC

Procedure

WARNING

Ensure that the electricity to the machine is switched off while performing tasks that do not need electricity. Disconnect the power cord. Electricity can cause death or injury. Moving parts can cause injury.

If a single occurrence, perform GP 9 to reload system software. **The error persists.**

Y N
| Perform SCP 6 Final Actions.

Check the Hard Drive harness connections. **The error persists.**

Y N
| Perform SCP 6 Final Actions.

Install a new Hard Drive.

16-608-28 to 16-608-67 Unable to Free IPC Resources

16-608-28 IPC unregister fail

16-608-35 Unable to Free IPC resources

16-608-38 Unable to unregister as IPC server

16-608-46 Unable to Free IPC resources

16-608-66 Unable to Free IPC resources

16-608-67 Unable to Free IPC resources

Procedure

WARNING

Ensure that the electricity to the machine is switched off while performing tasks that do not need electricity. Disconnect the power cord. Electricity can cause death or injury. Moving parts can cause injury.

If a single occurrence, the network controller automatically retries. **The error persists.**

Y N
| Perform SCP 6 Final Actions.

Cycle system power. **The error persists.**

Y N
| Perform SCP 6 Final Actions.

Perform GP 9 to reload system software.

16-608-105 Build UI SVC Obtain Client Failed

16-608-105 Build UI SVC obtain client failed

Procedure

WARNING

Ensure that the electricity to the machine is switched off while performing tasks that do not need electricity. Disconnect the power cord. Electricity can cause death or injury. Moving parts can cause injury.

If a single occurrence, the network controller automatically retries. **The error persists.**

Y N
| Perform SCP 6 Final Actions.

Cycle system power. **The error persists.**

Y N
| Perform SCP 6 Final Actions.

Perform GP 9 to reload system software.

16-609-07 Unknown Message Received

16-609-07 Unknown message received from DM agent

Procedure

WARNING

Ensure that the electricity to the machine is switched off while performing tasks that do not need electricity. Disconnect the power cord. Electricity can cause death or injury. Moving parts can cause injury.

If a single occurrence, perform GP 9 to reload system software. **The error persists.**

Y N
| Perform SCP 6 Final Actions.

Check the Hard Drive harness connections. **The error persists.**

Y N
| Perform SCP 6 Final Actions.

Install a new Hard Drive, REP 18.1.97

16-609-19 to 16-609-105 Invalid IPC Data Failure

16-609-19 Invalid RPC data received

16-609-26 IPC Fault Service

16-609-46 Invalid IPC Data Received

16-609-47 Invalid IPC Data

16-609-92 Invalid IPC Data Received

16-609-105 Too many IPC handlers

Procedure

WARNING

Ensure that the electricity to the machine is switched off while performing tasks that do not need electricity. Disconnect the power cord. Electricity can cause death or injury. Moving parts can cause injury.

If a single occurrence, perform GP 9 to reload system software. **The error persists.**

Y N
| Perform SCP 6 Final Actions.

Check the Hard Drive harness connections. **The error persists.**

Y N
| Perform SCP 6 Final Actions.

Install a new Hard Drive, REP 18.1.97

16-610-00, 16-610-07 IPC Send Failure

16-610-00 IPC send failure to NC TripleA service

16-610-07 IPC Send Failure to DM Agent

Procedure

WARNING

Ensure that the electricity to the machine is switched off while performing tasks that do not need electricity. Disconnect the power cord. Electricity can cause death or injury. Moving parts can cause injury.

If a single occurrence, the network controller automatically retries. **The error persists.**

Y N
| Perform SCP 6 Final Actions.

Cycle system power. **The error persists.**

Y N
| Perform SCP 6 Final Actions.

Perform GP 9 to reload system software.

16-610-09 Cannot send IPC Message to NC Platform

16-610-09 Cannot send IPC message to NC Platform Manage

Procedure

WARNING

Ensure that the electricity to the machine is switched off while performing tasks that do not need electricity. Disconnect the power cord. Electricity can cause death or injury. Moving parts can cause injury.

Cycle system power. **The error persists.**

Y N
| Perform SCP 6 Final Actions.

Perform GP 9 to reload system software.

16-610-11 to 16-610-90 Unable to Send IPC Message

16-610-11 IPC communication failed

16-610-19 Unable to send IPC message

16-610-26 Unable to send IPC message

16-610-28 IPC communication failed

16-610-35 Unable to send IPC message

16-610-46 Unable to send IPC message

16-610-90 IPC send response error

Procedure

WARNING

Ensure that the electricity to the machine is switched off while performing tasks that do not need electricity. Disconnect the power cord. Electricity can cause death or injury. Moving parts can cause injury.

If a single occurrence, the network controller automatically retries. **The error persists.**

Y N
| Perform SCP 6 Final Actions.

Cycle system power. **The error persists.**

Y N
| Perform SCP 6 Final Actions.

Perform GP 9 to reload system software.

16-610-92 Failure to Send Queue Status

16-610-92 Failure to send queue status

Procedure

WARNING

Ensure that the electricity to the machine is switched off while performing tasks that do not need electricity. Disconnect the power cord. Electricity can cause death or injury. Moving parts can cause injury.

Cycle system power. **The error persists.**

Y N
| Perform SCP 6 Final Actions.

Perform GP 9 to reload system software.

16-610-99 Unable to Send IPC Message RAP

16-610-99 Unable to send IPC message

Procedure

WARNING

Ensure that the electricity to the machine is switched off while performing tasks that do not need electricity. Disconnect the power cord. Electricity can cause death or injury. Moving parts can cause injury.

If a single occurrence, the network controller automatically retries. **The error persists.**

Y N
| Perform SCP 6 Final Actions.

Cycle system power. **The error persists.**

Y N
| Perform SCP 6 Final Actions.

Perform GP 9 to reload system software.

16-611-07, 16-611-38 Client Removal Failure

16-611-07 Client removal failure

16-611-38 Client removal failure

Procedure

WARNING

Ensure that the electricity to the machine is switched off while performing tasks that do not need electricity. Disconnect the power cord. Electricity can cause death or injury. Moving parts can cause injury.

If a single occurrence, the network controller automatically retries. **The error persists.**

Y N
| Perform SCP 6 Final Actions.

Cycle system power. **The error persists.**

Y N
| Perform SCP 6 Final Actions.

Perform GP 9 to reload system software.

16-611-19 to 16-611-99 Unable to Remove RPC Connection

16-611-09 Cannot remove RPC connection

16-611-14 Cannot remove RPC connection

16-611-19 Unable to remove RPC connection

16-611-26 Cannot remove RPC connection

16-611-46 Cannot remove RPC connection

16-611-47 Cannot remove RPC connection

16-611-66 Unable to remove RPC connection

16-611-67 Unable to remove RPC connection

16-611-99 Cannot remove RPC connection

Procedure

WARNING

Ensure that the electricity to the machine is switched off while performing tasks that do not need electricity. Disconnect the power cord. Electricity can cause death or injury. Moving parts can cause injury.

If a single occurrence, the network controller automatically retries. **The error persists.**

Y N
| Perform SCP 6 Final Actions.

Cycle system power. **The error persists.**

Y N
| Perform SCP 6 Final Actions.

Perform GP 9 to reload system software.

16-612-09 to 16-612-68 Unable to Do Shutdown Sync RAP

16-612-09 Unable to do shutdown synchronization

16-612-14 Unable to do shutdown synchronization

16-612-35 Unable to do shutdown synchronization

16-612-46 Unable to do shutdown synchronization

16-612-68 Unable to do shutdown synchronization

Procedure

WARNING

Ensure that the electricity to the machine is switched off while performing tasks that do not need electricity. Disconnect the power cord. Electricity can cause death or injury. Moving parts can cause injury.

If a single occurrence, the network controller automatically retries. **The error persists.**

Y N
| Perform SCP 6 Final Actions.

Cycle system power. **The error persists.**

Y N
| Perform SCP 6 Final Actions.

Perform GP 9 to reload system software.

16-612-47 Upgrade Request Failed - Downgrade Not Allowed

03-306-00 Downgrade of system software not allowed

The reload process is aborted and the printer resets. If configured, an email alert is sent and upgrade report printed. An entry is made in Upgrade History log.

Procedure

WARNING

Ensure that the electricity to the machine is switched off while performing tasks that do not need electricity. Disconnect the power cord. Electricity can cause death or injury. Moving parts can cause injury.

Obtain the current system software set, then perform GP 9 to reload system software. **The error persists.**

Y N
| Perform SCP 6 Final Actions.

Perform GP 9 to reload system software.

16-613-09 to 16-614-19 DC Sync / Comms Error

16-613-09 DC registration synchronization error

16-613-14 DC ENS synchronization error

16-613-19 DC sys mgr sync error

16-614-09 DC registration communications error

16-614-14 Digital copier ENS registration error

16-614-19 DC sys mgr communications error

Procedure

WARNING

Ensure that the electricity to the machine is switched off while performing tasks that do not need electricity. Disconnect the power cord. Electricity can cause death or injury. Moving parts can cause injury.

Cycle system power. **The error persists.**

Y N
| Perform SCP 6 Final Actions.

Perform GP 9 to reload system software.

16-614-47 Invalid Software Upgrade

16-614-47 Invalid SW upgrade file

The reload process is aborted and the printer resets. If configured, an email alert is sent and upgrade report printed. An entry is made in Upgrade History log.

Procedure

WARNING

Ensure that the electricity to the machine is switched off while performing tasks that do not need electricity. Disconnect the power cord. Electricity can cause death or injury. Moving parts can cause injury.

Obtain the current system software set, then perform GP 9 to reload system software. **The error persists.**

Y N
| Perform SCP 6 Final Actions.

Perform GP 9 to reload system software.

16-615-35 to 16-615-90 SESS Data Store Variable Not Set

16-615-35 SESS data store environmental variable not set

16-615-46 SESS data store environmental variable not set

16-615-66 SESS data store environmental variable not set

16-615-67 SESS data store environmental variable not set

16-615-90 SESS data store environmental variable not set

Procedure

WARNING

Ensure that the electricity to the machine is switched off while performing tasks that do not need electricity. Disconnect the power cord. Electricity can cause death or injury. Moving parts can cause injury.

Cycle system power. **The error persists.**

Y N
| Perform SCP 6 Final Actions.

Perform GP 9 to reload system software.

16-615-47 Multiple Software Upgrade File

16-615-47 Multiple SW upgrade files in directory

The reload process is aborted and the printer resets. If configured, an email alert is sent and upgrade report printed. An entry is made in Upgrade History log.

Procedure

WARNING

Ensure that the electricity to the machine is switched off while performing tasks that do not need electricity. Disconnect the power cord. Electricity can cause death or injury. Moving parts can cause injury.

Remove all but the current system software set, then perform GP 9 to reload system software.

The error persists.

Y N
| Perform SCP 6 Final Actions.

Perform GP 9 to reload system software.

16-616-35 to 16-616-46 Data Store Initialization Failure

16-616-35 Data Store initialization failure

16-616-38 Error - Shared Memory Failure

16-616-46 Data Store Initialization Failed

Procedure

WARNING

Ensure that the electricity to the machine is switched off while performing tasks that do not need electricity. Disconnect the power cord. Electricity can cause death or injury. Moving parts can cause injury.

If a single occurrence, the network controller automatically retries. **The error persists.**

Y N
| Perform SCP 6 Final Actions.

Cycle system power. **The error persists.**

Y N
| Perform SCP 6 Final Actions.

Perform GP 9 to reload system software.

16-616-47 IPC Message Failure

16-616-47 IPC message failure.

Procedure

WARNING

Ensure that the electricity to the machine is switched off while performing tasks that do not need electricity. Disconnect the power cord. Electricity can cause death or injury. **Moving parts can cause injury.**

If a single occurrence, the network controller automatically retries. **The error persists.**

Y N
| Perform SCP 6 Final Actions.

Cycle system power. **The error persists.**

Y N
| Perform SCP 6 Final Actions.

Perform GP 9 to reload system software.

16-616-67 Submission of Email or IFax Job Failed

16-616-67 Submission of Email or IFax Job Failed

Procedure

WARNING

Ensure that the electricity to the machine is switched off while performing tasks that do not need electricity. Disconnect the power cord. Electricity can cause death or injury. **Moving parts can cause injury.**

If a single occurrence, the network controller automatically retries. **The error persists.**

Y N
| Perform SCP 6 Final Actions.

Cycle system power. **The error persists.**

Y N
| Perform SCP 6 Final Actions.

Send a different job. **The error persists.**

Y N
| Perform SCP 6 Final Actions.

Save customer NVM with dC361, then reset and restore NVM. **The error persists.**

Y N
| Perform SCP 6 Final Actions.

Perform GP 9 to reload system software.

16-617-19 Send Event Failure Unable to send event to NC

16-617-19 Send Event Failure Unable to send event to NC ENS

Procedure

WARNING

Ensure that the electricity to the machine is switched off while performing tasks that do not need electricity. Disconnect the power cord. Electricity can cause death or injury. Moving parts can cause injury.

Cycle system power. **The error persists.**

Y N
| Perform SCP 6 Final Actions.

Perform GP 9 to reload system software.

16-617-47 Upgrade Request Failed -TAR Extraction Failure

16-617-47 TAR extraction failure

The reload process is aborted and the printer resets. If configured, an email alert is sent and upgrade report printed. An entry is made in Upgrade History log.

Procedure

WARNING

Ensure that the electricity to the machine is switched off while performing tasks that do not need electricity. Disconnect the power cord. Electricity can cause death or injury. Moving parts can cause injury.

For a single occurrence, cycle system power. **The error persists.**

Y N
| Perform SCP 6 Final Actions.

Perform GP 9 to reload system software.

16-618-47 DLM SPI Extraction Failure RAP

16-618-47 DLM SPI Extraction failure

Procedure

WARNING

Ensure that the electricity to the machine is switched off while performing tasks that do not need electricity. Disconnect the power cord. Electricity can cause death or injury. Moving parts can cause injury.

Cycle system power. **The error persists.**

Y **N**
| Perform SCP 6 Final Actions.

Perform GP 9 to reload system software.

16-619-14 to 16-619-93 Unable to unregister Registration service

16-619-14 Unable to unregister Registration service

16-619-19 Unable to unregister Registration service

16-619-26 Could not unregister with Registration Service

16-619-46 Unable to unregister with NC due to RPC timeout

16-619-68 Unable to unregister with NC due to RPC timeout

16-619-93 Unable to unregister with NC due to RPC timeout

Procedure

WARNING

Ensure that the electricity to the machine is switched off while performing tasks that do not need electricity. Disconnect the power cord. Electricity can cause death or injury. Moving parts can cause injury.

Cycle system power. **The error persists.**

Y **N**
| Perform SCP 6 Final Actions.

Perform GP 9 to reload system software.

16-619-47 Upgrade Request Failed - DMPR Failure at Web

16-619-47 Upgrade request failed - DMPR failure at web

The reload process is aborted and the printer resets. If configured, an email alert is sent and upgrade report printed. An entry is made in Upgrade History log.

Procedure

WARNING

Ensure that the electricity to the machine is switched off while performing tasks that do not need electricity. Disconnect the power cord. Electricity can cause death or injury. Moving parts can cause injury.

For a single occurrence, cycle system power. **The error persists.**

Y N
| Perform SCP 6 Final Actions.

Perform GP 9 to reload system software.

16-620-07 to 16-620-99 Registration Service Failed

16-620-07 Failure to unregister with NC

16-620-14 Unable to unregister Registration service

16-620-19 Unable to unregister Registration service

16-620-35 Unable to unregister Registration service

16-620-38 Unable to unregister with NC Registration Service

16-620-39 Completed job log is unable to Unregister with Registration Service

16-620-46 Unable to Unregister with Registration Service

16-620-90 Unable to unregister with NC (Reg Service failure)

16-620-92 Unable to unregister with Registration Service

16-620-93 Unable to unregister with NC (Reg Service failure)

16-620-99 Unable to unregister with NC (Reg Service failure)

Procedure

WARNING

Ensure that the electricity to the machine is switched off while performing tasks that do not need electricity. Disconnect the power cord. Electricity can cause death or injury. Moving parts can cause injury.

Cycle system power. **The error persists.**

Y N
| Perform SCP 6 Final Actions.

Perform GP 9 to reload system software.

16-620-47 Upgrade Request Rejected

16-620-47 Upgrade request rejected

The reload process is aborted and the printer resets. If configured, an email alert is sent and upgrade report printed. An entry is made in Upgrade History log.

Procedure

WARNING

Ensure that the electricity to the machine is switched off while performing tasks that do not need electricity. Disconnect the power cord. Electricity can cause death or injury. Moving parts can cause injury.

For a single occurrence, cycle system power. **The error persists.**

Y N
| Perform SCP 6 Final Actions.

Perform GP 9 to reload system software.

16-621-00 to 16-621-99 Unable to Get Host Name

16-621-00 Unable to get host name

16-621-07 Unable to get host name

16-621-11 Unable to get host name

16-621-28 Unable to get host name

16-621-35 Get Host Name failed

16-621-38 Unable to get host name

16-621-47 Get Host Name failed

16-621-66 Unable to get the host name

16-621-67 Unable to get the host name

16-621-93 Unable to get host name

16-621-99 Get Host Name failed

Initial Actions

Check printer network settings.

Procedure

WARNING

Ensure that the electricity to the machine is switched off while performing tasks that do not need electricity. Disconnect the power cord. Electricity can cause death or injury. Moving parts can cause injury.

Cycle system power. **The error persists.**

Y N
| Perform SCP 6 Final Actions.

Perform GP 9 to reload system software.

16-622-07 to 16-622-46 Corrupt O/S RPC Table

16-622-07 Corrupt O/S RPC Table

16-622-09 Corrupt O/S RPC Table

16-622-11 Corrupt O/S RPC Table

16-622-14 Corrupt O/S RPC Table

16-622-19 Corrupt O/S RPC Table

16-622-26 Corrupt O/S RPC Table

16-622-28 Corrupt O/S RPC Table

16-622-35 Corrupt O/S RPC Table

16-622-38 Corrupt O/S RPC Table

16-622-46 Corrupt O/S RPC Table

16-622-47 Software upgrade file failure.

Procedure

WARNING

Ensure that the electricity to the machine is switched off while performing tasks that do not need electricity. Disconnect the power cord. Electricity can cause death or injury. Moving parts can cause injury.

Cycle system power. **The error persists.**

Y N
| Perform SCP 6 Final Actions.

Perform GP 9 to reload system software.

16-622-47 FTP "get" Failure

16-622-47 FTP "get" failure

The reload process is aborted and the printer resets. If configured, an email alert is sent and upgrade report printed. An entry is made in Upgrade History log.

Procedure

WARNING

Ensure that the electricity to the machine is switched off while performing tasks that do not need electricity. Disconnect the power cord. Electricity can cause death or injury. Moving parts can cause injury.

For a single occurrence, cycle system power. **The error persists.**

Y N
| Perform SCP 6 Final Actions.

Perform GP 9 to reload system software.

16-622-66 to 16-622-68 Failed to Unregister as RPC Service During Shutdown

16-622-66 Failed to unregister as RPC service during shutdown

16-622-67 Failed to unregister as RPC service during shutdown

16-622-68 Cannot unregister from registration service

Procedure

WARNING

Ensure that the electricity to the machine is switched off while performing tasks that do not need electricity. Disconnect the power cord. Electricity can cause death or injury. Moving parts can cause injury.

Cycle system power. **The error persists.**

Y N
| Perform SCP 6 Final Actions.

Perform GP 9 to reload system software.

16-623-35, 16-623-47, 16-624-46 RPC Call Failure

16-623-35 RPC Call Failure to ENS

16-623-47 RPC Call Failure to ENS

16-624-46 Unable to create RPC connection

Procedure

WARNING

Ensure that the electricity to the machine is switched off while performing tasks that do not need electricity. Disconnect the power cord. Electricity can cause death or injury. Moving parts can cause injury.

Cycle system power. **The error persists.**

Y N
| Perform SCP 6 Final Actions.

Perform GP 9 to reload system software.

16-625-35 to 16-625-90 Invalid IPC Type

16-625-35 Invalid IPC Type

16-625-46 Invalid IPC Message Type

16-625-66 Invalid IPC Message Type

16-625-67 Invalid IPC Message Type

16-625-90 Invalid Queue Service IPC message type

Procedure

WARNING

Ensure that the electricity to the machine is switched off while performing tasks that do not need electricity. Disconnect the power cord. Electricity can cause death or injury. Moving parts can cause injury.

Cycle system power. **The error persists.**

Y N
| Perform SCP 6 Final Actions.

Perform GP 9 to reload system software.

16-626-00 to 16-626-67 Memory Allocation Error

16-626-00 Memory Allocation Error

16-626-11 Can't allocate memory to load a template

16-626-38 Memory Allocation Error

16-626-47 Memory Allocation Error

16-626-67 Memory allocation failed

Procedure

WARNING

Ensure that the electricity to the machine is switched off while performing tasks that do not need electricity. Disconnect the power cord. Electricity can cause death or injury. Moving parts can cause injury.

Cycle system power. **The error persists.**

Y N
| Perform SCP 6 Final Actions.

Reseat ESS Board RAM. **The error persists.**

Y N
| Perform SCP 6 Final Actions.

Use dC361 to save customer NVM settings, then reset and restore NVM. **The error persists.**

Y N
| Perform SCP 6 Final Actions.

Perform GP 9 to reload system software.

16-628-07 to 16-628-67 Range String Variable Error

16-628-07 Range String could not be computed

16-628-09 Unable to complete RPC call

16-628-35 Unable to complete RPC call

16-628-46 Range String calculation failed

16-628-66 Object write value out of range

16-628-67 Cannot get range environment variable

Procedure

WARNING

Ensure that the electricity to the machine is switched off while performing tasks that do not need electricity. Disconnect the power cord. Electricity can cause death or injury. Moving parts can cause injury.

Cycle system power. **The error persists.**

Y N
| Perform SCP 6 Final Actions.

Perform GP 9 to reload system software.

16-629-11 to 16-629-93 No Acknowledgment For RPC

16-629-11 RPC call failure

16-629-26 Fault Service Call to PSW Callback failed

16-629-46 No Acknowledgment to RPC Message. RPC time-out

16-629-67 No acknowledgment for RPC message.

16-629-68 No acknowledgment for RPC message.

16-629-92 No Acknowledgment to RPC Message. RPC timeout.

16-629-93 No Acknowledgment to RPC Message. RPC timeout

Procedure

WARNING

Ensure that the electricity to the machine is switched off while performing tasks that do not need electricity. Disconnect the power cord. Electricity can cause death or injury. Moving parts can cause injury.

Cycle system power. **The error persists.**

Y N
| Perform SCP 6 Final Actions.

Perform GP 9 to reload system software.

16-630-09 to 16-630-99 Unable to Get RPC Client Handle

16-630-09 Unable to connect to a service using RPC

16-630-26 Fault Service Failed to get RPC Client Handle

16-630-35 Unable to Get RPC Client Handle

16-630-38 Client Create Failed

16-630-46 Unable to Get RPC Client Handle

16-630-47 Unable to Get RPC Client Handle

16-630-66 Unable to get RPC client handle.

16-630-67 Unable to get RPC client handle.

16-630-68 Unable to get RPC client handle.

16-630-99 Unable to Get RPC Client Handle

Procedure

WARNING

Ensure that the electricity to the machine is switched off while performing tasks that do not need electricity. Disconnect the power cord. Electricity can cause death or injury. Moving parts can cause injury.

Cycle system power. **The error persists.**

Y N
| Perform SCP 6 Final Actions.

Perform GP 9 to reload system software.

16-631-19 to 16-636-99 XDR Data Error

16-631-19 Invalid Event Notification Received

16-631-46 Unexpected Event Notification

16-633-19 NVM Detach Error

16-634-46 Unable to specify Shutdown Routine during Initialization

16-635-07 Cannot free XDR data

16-635-35 Cannot free XDR data

16-635-46 Unable to free XDR data

16-635-99 Cannot free XDR data

16-636-35 Unable to unmarshall XDR data

16-636-99 Unable to unmarshall XDR data

Procedure

WARNING

Ensure that the electricity to the machine is switched off while performing tasks that do not need electricity. Disconnect the power cord. Electricity can cause death or injury. Moving parts can cause injury.

Cycle system power. **The error persists.**

Y N
| Perform SCP 6 Final Actions.

Perform GP 9 to reload system software.

16-637-11 to 16-637-95 File Error

16-637-11 Can't open template cache file

16-637-26 Unable to open file

16-637-38 Unable to Open File for Write

16-637-47 Failed to Open File

16-637-66 File I/O error.

16-637-67 File I/O error.

16-637-93 Unable to open local file

16-637-95 Unable to open local file

Procedure

WARNING

Ensure that the electricity to the machine is switched off while performing tasks that do not need electricity. Disconnect the power cord. Electricity can cause death or injury. Moving parts can cause injury.

Cycle system power. **The error persists.**

Y N
| Perform SCP 6 Final Actions.

Perform GP 9 to reload system software.

16-638-66 to 16-641-46 O/S Failure

16-638-66 Unable to initialize with queue library

16-638-67 Unable to initialize with queue library

16-639-38 Create Thread Fault

16-639-46 Pthread create error

16-640-28 RPC call failure

16-640-35 RPC send

16-640-46 Unable to create Semaphore

16-641-00 Cannot log fault to NC Fault Log

16-641-26 Cannot log fault to ess fault log

16-641-46 Cannot log fault to NC fault service

Procedure

WARNING

Ensure that the electricity to the machine is switched off while performing tasks that do not need electricity. Disconnect the power cord. Electricity can cause death or injury. Moving parts can cause injury.

Cycle system power. **The error persists.**

Y N
| Perform SCP 6 Final Actions.

Perform GP 9 to reload system software.

16-642-46 to 16-645-67 File I/O Errors

16-642-46 Invalid Internal Parameters

16-642-47 Invalid Internal Parameters

16-643-19 Unable to close file

16-643-26 Unable to close file

16-643-47 Failed to close a file

16-644-11 Can't read template cache file

16-644-26 Unable to read from file

16-644-47 SWVerify Get_next_proc failed

16-644-66 File I/O error

16-644-67 File I/O error

16-645-11 Can't write updated template cache file

16-645-26 Unable to write to file

16-645-46 Failed to Write File

16-645-47 Failed to Write File

16-645-66 File I/O error

16-645-67 File I/O error

Procedure

WARNING

Ensure that the electricity to the machine is switched off while performing tasks that do not need electricity. Disconnect the power cord. Electricity can cause death or injury. Moving parts can cause injury.

Cycle system power. **The error persists.**

Y N
| Perform SCP 6 Final Actions.

Perform GP 9 to reload system software.

16-646-26 to 16-650-99 Invalid Service Attribute

16-646-26 Failed to delete file

16-647-19 Unable to get Time and Date

16-647-26 Unable to become Client of Diag Service

16-649-35 Invalid service attribute defaults

16-650-35 Invalid service attribute requested

16-650-99 Invalid service attribute requested

Procedure

WARNING

Ensure that the electricity to the machine is switched off while performing tasks that do not need electricity. Disconnect the power cord. Electricity can cause death or injury. Moving parts can cause injury.

Cycle system power. **The error persists.**

Y N
| Perform SCP 6 Final Actions.

Perform GP 9 to reload system software.

16-651-19 to 16-656-38 Registration Failure

16-651-19 Cannot register for SESS Events

16-651-35 Cannot register for SESS Events

16-651-99 SPI register failed

16-652-38 Unable to Enroll Spi Callbacks

16-652-99 SPI enroll failed

16-653-38 Error - Invalid Job Handle Fault

16-654-38 Return from spi_register Fault

16-654-99 Return from Log_init Fault

16-655-38 Return from spi_register Fault

16-656-38 RPC processing fault

Procedure

WARNING

Ensure that the electricity to the machine is switched off while performing tasks that do not need electricity. Disconnect the power cord. Electricity can cause death or injury. Moving parts can cause injury.

Cycle system power. **The error persists.**

Y N
| Perform SCP 6 Final Actions.

Perform GP 9 to reload system software.

16-658-07 Unable to Get Host Name

16-658-07 Unable to get host name

Initial Actions

Check printer network settings.

Procedure

WARNING

Ensure that the electricity to the machine is switched off while performing tasks that do not need electricity. Disconnect the power cord. Electricity can cause death or injury. Moving parts can cause injury.

Cycle system power. **The error persists.**

Y N
| Perform SCP 6 Final Actions.

Perform GP 9 to reload system software.

16-658-07 to 16-667-95 Parser Utility Errors

- 16-659-11 Parser utility open failure.
- 16-659-28 Parser utility open failure.
- 16-659-93 Parser utility open failure.
- 16-659-95 Parser utility open failure.
- 16-660-95 Cannot read local directory entries.
- 16-660-99 Service initialization failed.
- 16-661-95 Cannot create spool directory.
- 16-662-11 Parser utility template failed to parse.
- 16-662-28 Parser utility template failed to parse.
- 16-662-93 Parser utility template failed to parse.
- 16-662-95 Parser utility template failed to parse.
- 16-663-11 Parser utility destroy template failed
- 16-663-28 Parser utility destroy template failed
- 16-663-93 Parser utility destroy template failed
- 16-663-95 Parser utility destroy template failed
- 16-664-11 Parser utility parser closing failed
- 16-664-28 Parser utility parser closing failed
- 16-664-93 Parser utility parser closing failed
- 16-664-95 Parser utility parser closing failed
- 16-665-95 Unable to detach from child thread
- 16-666-11 Parser utility invocation failed.
- 16-666-28 Parser utility invocation failed.
- 16-666-93 Parser utility invocation failed.
- 16-666-95 Parser utility invocation failed
- 16-667-11 Parser utility set status failed.

16-667-28 Parser utility set status failed.

16-667-95 Parser utility set status failed.

Procedure

WARNING

Ensure that the electricity to the machine is switched off while performing tasks that do not need electricity. Disconnect the power cord. Electricity can cause death or injury. Moving parts can cause injury.

Cycle system power. **The error persists.**

Y N
| Perform SCP 6 Final Actions.

Perform GP 9 to reload system software.

16-668-47 Write NVM Failed

16-668-47 Write NVM Failed

Procedure

WARNING

Ensure that the electricity to the machine is switched off while performing tasks that do not need electricity. Disconnect the power cord. Electricity can cause death or injury. Moving parts can cause injury.

Cycle system power. **The error persists.**

Y N
| Perform SCP 6 Final Actions.

Perform GP 9 to reload system software. **The error persists.**

Y N
| Perform SCP 6 Final Actions.

Replace the ESS Board, REP 18.1.98.

16-668-93, 16-668-95 Unable To Determine Local File Statistics

16-668-93 Unable to determine local file statistics

16-668-95 Unable to determine local file statistics

Procedure

WARNING

Ensure that the electricity to the machine is switched off while performing tasks that do not need electricity. Disconnect the power cord. Electricity can cause death or injury. Moving parts can cause injury.

Cycle system power. **The error persists.**

Y N
| Perform SCP 6 Final Actions.

Perform GP 9 to reload system software.

16-669-28 to 16-670-00 Unable To Write Job Template

16-669-28 Unable to write job template to network controller disk.

16-669-93 Unable to write job template to network controller disk.

16-669-95 Unable to write job template to network controller disk.

16-670-00 Unable to lock/unlock data store.

Procedure

WARNING

Ensure that the electricity to the machine is switched off while performing tasks that do not need electricity. Disconnect the power cord. Electricity can cause death or injury. Moving parts can cause injury.

Cycle system power. **The error persists.**

Y N
| Perform SCP 6 Final Actions.

Perform GP 9 to reload system software.

16-670-11 to 16-671-47 Unable To Decode Template File

16-670-11 Unable to decode template file

16-670-28 Unable to decode template file

16-670-47 Save NVM Failed

16-670-93 Unable to decode template file

16-671-00 Sort jobs failed

16-671-47 Init NVM failed

Procedure

WARNING

Ensure that the electricity to the machine is switched off while performing tasks that do not need electricity. Disconnect the power cord. Electricity can cause death or injury. Moving parts can cause injury.

Cycle system power. **The error persists.**

Y N
| Perform SCP 6 Final Actions.

Perform GP 9 to reload system software.

16-671-93 to 16-673-95 File Error

16-671-93 Unable to encode template file

16-671-95 Unable to encode template file

16-672-09 Unable to remove file from system

16-672-95 Unable to remove file from system

16-673-95 Cannot remove local directory

Procedure

WARNING

Ensure that the electricity to the machine is switched off while performing tasks that do not need electricity. Disconnect the power cord. Electricity can cause death or injury. Moving parts can cause injury.

Cycle system power. **The error persists.**

Y N
| Perform SCP 6 Final Actions.

Perform GP 9 to reload system software.

16-674-00 to 16-709-00 XSA Database Error

16-674-00 XSA RPC Server Death

16-674-09 XSA RPC Server Death

16-675-00 XSA Database Server Death

16-700-00 Unknown Attribute Requested

16-700-35 Unknown attribute requested

16-701-00 Unable to communicate with XSA database

16-701-68 Unable to communicate with Postgre database. Status code 16-536 is raised with this fault code.

16-701-99 Unable to communicate with XSA database

16-702-00 Unable to communicate with XSA database

16-702-95 Unable to communicate with XSA database

16-707-00 Unknown Queue Request received

16-709-00 Unknown Modify request received

Procedure

WARNING

Ensure that the electricity to the machine is switched off while performing tasks that do not need electricity. Disconnect the power cord. Electricity can cause death or injury. Moving parts can cause injury.

Cycle system power. **The error persists.**

Y N
| Perform SCP 6 Final Actions.

Perform GP 9 to reload system software.

16-710-00 to 16-750-11 Unable To Create Client Handle

16-710-00 NC Internal Communication Failure

16-710-35 IPC send failure

16-716-00 Data Store init failed

16-716-00 Data Store init failed

16-718-00 Data Store Full

16-718-00 Data Store Full

16-720-00 Disk Partition Full

16-720-00 Disk Partition Full

16-728-00 Unable to compute Range String

16-730-00 Unable to create Client Handle

16-730-35 Unable to create Client Handle

16-730-66 Unable to create Client Handle

16-740-19 Error - NC Hard Disk IIO Failure

16-742-19 On Demand Image overwrite failed

16-750-07 Message Received from DM not Processed correctly

16-750-09 Cannot Add existing Service

16-750-11 Template cache file is missing

Procedure

WARNING

Ensure that the electricity to the machine is switched off while performing tasks that do not need electricity. Disconnect the power cord. Electricity can cause death or injury. Moving parts can cause injury.

Cycle system power. **The error persists.**

Y N
| Perform SCP 6 Final Actions.

Perform GP 9 to reload system software.

16-750-14 to 16-750-90 Invalid Request

16-750-14 Retry SNMP event registration

16-750-19 Invalid Online/ Offline request

16-750-26 Invalid number of faults requested

16-750-35 Queue Service library Initialization failed

16-750-38 Error - SPI Init Fault

16-750-46 Unknown Object (on Read)

16-750-47 SC Diag Startup failed

16-750-66 Failure to set service state

16-750-67 Failure to set service state

16-750-90 Invalid Queue Service IPC Queue ID

Procedure

WARNING

Ensure that the electricity to the machine is switched off while performing tasks that do not need electricity. Disconnect the power cord. Electricity can cause death or injury. Moving parts can cause injury.

Cycle system power. **The error persists.**

Y N
| Perform SCP 6 Final Actions.

Perform an "On Demand Overwrite" (ODIO) using the control panel:

1. Press the [Log In/Out] button on the Control Panel.
2. Use the keyboard to enter the User Name of the Administrator account.
3. Select the [Next] button.
4. Use the keyboard to enter the Password of the Administrator account then select the [Done] button.
(Default UserName is **admin**, the default Password for the Machine is **1111**).
5. Press the [Machine Status] button.
6. Press the [Tools] tab.
7. Select [Security Settings].
8. Select [Image Overwrite Security].
9. Select the [Disk Overwrite Now] tab.
10. Press the [Overwrite Now] button.

Note 1 : The Overwrite will take approximately 20 minutes to complete.

Note 2 : Disabling image overwrite will prevent the necessity of the customer ever having to run an ODIO, but needs to be acceptable / understood by the Customer. If disabling image overwrite is not an option, then set it to weekly scheduled overnight. To disable image overwrite, go to:

Admin / Machine Status / Tools / Security Settings / Image overwrite security / Disable or Enable

If problem persists, perform GP9 to reload system software.

16-750-92 to 16-751-26 Database Error

- 16-750-92 Bad file descriptor
- 16-750-93 IFS error when requesting memory
- 16-750-95 Local Spool area does not exist
- 16-751-00 Database Error known by Service Registry or registry not available
- 16-751-07 Message Received from NC AAA not Processed correctly
- 16-751-09 Registration receives unrequested ENS notification
- 16-751-11 Initialization procedure fails
- 16-751-14 SESS SC event registration failed
- 16-751-19 Unable to set time / date
- 16-751-26 Unrecognized Fault Code

Procedure

WARNING

Ensure that the electricity to the machine is switched off while performing tasks that do not need electricity. Disconnect the power cord. Electricity can cause death or injury. Moving parts can cause injury.

Cycle system power. **The error persists.**

Y N
| Perform SCP 6 Final Actions.

Perform GP 9 to reload system software.

16-751-28 to 16-751-93 Unknown Attribute

- 16-751-28 Templates attributes are invalid, or syntax error
- 16-751-35 Failure to initialize with DM Agent
- 16-751-38 Warning- Unknown Attribute
- 16-751-46 Unknown Object (on Write)
- 16-751-47 SWVerify RepairDir failed
- 16-751-66 Unable to send event to NC ENS
- 16-751-67 Unable to send event to NC ENS
- 16-751-92 Job State Fault
- 16-751-93 Invalid template attribute

Procedure

WARNING

Ensure that the electricity to the machine is switched off while performing tasks that do not need electricity. Disconnect the power cord. Electricity can cause death or injury. Moving parts can cause injury.

Cycle system power. **The error persists.**

Y N
| Perform SCP 6 Final Actions.

Perform GP 9 to reload system software.

16-752-00 to 16-752-47 Invalid File Details

16-752-00 File Cabinet Application Registration Error. Status code 17-552 is raised with this fault code.

16-752-07 Queue Service Library Initialization Failed

16-752-09 Attempt to register too many services

16-752-14 Retry SESS Sys Control event registration

16-752-19 Cannot Acknowledge System Mode Change

16-752-26 Unrecognized SESS Error Code

16-752-28 Template cache file is missing

16-752-35 Failure to initialize with PrintSpi

16-752-46 Invalid table row (on Read)

16-752-47 Invalid Test Pattern Source

Procedure

WARNING

Ensure that the electricity to the machine is switched off while performing tasks that do not need electricity. Disconnect the power cord. Electricity can cause death or injury. Moving parts can cause injury.

Cycle system power. **The error persists.**

Y	N
	Perform SCP 6 Final Actions.

Perform GP 9 to reload system software.

16-752-66 to 16-753-28 Scan to FAX Registration Error

16-752-66 Scan to FAX services registration error

16-752-67 Scan to Distribution services registration error

16-752-92 Printsipi can't read frame type from data store

16-752-93 Error accessing job(s) in job list

16-752-95 File transfer operation failure

16-753-00 File Cabinet Application Un-Registration Error. Status code 17-561 is raised with this fault code.

16-753-09 No. of services attempt to go below zero

16-753-14 Invalid event number error received by ENS

16-753-19 Unable to send event to NC ENS

16-753-26 Unable to become Client of PSW

16-753-28 Cannot communicate with UI for template list request

Procedure

WARNING

Ensure that the electricity to the machine is switched off while performing tasks that do not need electricity. Disconnect the power cord. Electricity can cause death or injury. Moving parts can cause injury.

Cycle system power. **The error persists.**

Y	N
	Perform SCP 6 Final Actions.

Perform GP 9 to reload system software.

16-753-35 to 16-754-09 Data Store Read Failure

16-753-35 Unable to change EJS status to offline

16-753-46 Invalid table row (on Write)

16-753-47 Failed to Close Directory

16-753-66 Data Store Read Failure

16-753-67 Data Store Read Failure

16-753-90 Null Return Address

16-753-92 Printsipi can't read frame type from data store

16-753-93 Error adding job(s) in job list

16-753-95 Requested transfer protocol not supported

16-754-09 Exiting w/NC services still registered

Procedure

WARNING

Ensure that the electricity to the machine is switched off while performing tasks that do not need electricity. Disconnect the power cord. Electricity can cause death or injury. Moving parts can cause injury.

Cycle system power. **The error persists.**

Y N
| Perform SCP 6 Final Actions.

Perform GP 9 to reload system software.

16-754-14 to 16-754-68 OS Error

16-754-14 Event notification via IPC error - no queue

16-754-19 Shutdown Request Reason Unknown

16-754-26 Fault Service encountered error reading fault log

16-754-28 Initialization procedure fails

16-754-35 Can not generate SESS event

16-754-46 Attempted write of read-only object

16-754-47 SWVerify Repair file failed

16-754-66 OS problem

16-754-67 OS problem

16-754-68 Initialize procedure fails

Procedure

WARNING

Ensure that the electricity to the machine is switched off while performing tasks that do not need electricity. Disconnect the power cord. Electricity can cause death or injury. Moving parts can cause injury.

Cycle system power. **The error persists.**

Y N
| Perform SCP 6 Final Actions.

Perform GP 9 to reload system software.

16-754-90 to 16-755-28 Fault Service Error

16-754-90 Attempt to Free Null Node

16-754-92 Consumer Interface Fault

16-754-93 Error deleting jobs from job list

16-754-95 Unable to remove advisory lock on network server

16-755-00 Service Registry cannot initialize database

16-755-09 Unable to register requested service

16-755-14 Event notification via IPC error - full queue

16-755-19 Unable to provide new s/w config to SESS

16-755-26 Fault Service failed to Clear Fault Log

16-755-28 Cancel Request Failed

Procedure

WARNING

Ensure that the electricity to the machine is switched off while performing tasks that do not need electricity. Disconnect the power cord. Electricity can cause death or injury. Moving parts can cause injury.

Cycle system power. **The error persists.**

Y N
| Perform SCP 6 Final Actions.

Perform GP 9 to reload system software.

16-755-35 to 16-756-14 Request Error

16-755-35 Unable to update Data Store attribute

16-755-46 Object type mismatch

16-755-47 SWVerify Repair permission failed

16-755-67 Cancel Request Failed

16-755-90 Exceeding Queue Array Size

16-755-93 Unable to initialize with IFS

16-755-99 Unable to abort job fault

16-756-09 Unable to unregister requesting service

16-756-14 RPC creation error: RPC coms to client services error

Procedure

WARNING

Ensure that the electricity to the machine is switched off while performing tasks that do not need electricity. Disconnect the power cord. Electricity can cause death or injury. Moving parts can cause injury.

Cycle system power. **The error persists.**

Y N
| Perform SCP 6 Final Actions.

Perform GP 9 to reload system software.

16-756-26 to 16-757-26 NVM Corrupt

16-756-26 Memory Allocation Failure

16-756-35 Unable to read NVM value

16-756-46 ServiceRun loop failed

16-756-47 SC Run Diagnostic failed

16-756-66 Unable to read NVM value

16-756-67 Unable to read NVM value

16-756-93 IPA operation failed

16-757-09 Invalid RPC parameters

16-757-14 RPC Control error

16-757-19 System Manager callback sm_operation complete failed

16-757-26 Fault Service could not close Fault Log

Procedure

WARNING

Ensure that the electricity to the machine is switched off while performing tasks that do not need electricity. Disconnect the power cord. Electricity can cause death or injury. Moving parts can cause injury.

Cycle system power. **The error persists.**

Y N
| Perform SCP 6 Final Actions.

Perform GP 9 to reload system software. **The error persists.**

Y N
| Perform SCP 6 Final Actions.

Replace the ESS Board, REP 18.1.98.

16-757-35 to 16-758-26 Unable to Write NVM

16-757-35 Unable to write NVM value

16-757-46 Failed to get a specific IPC queue

16-757-47 SWVerify Repair chksum failed

16-757-66 Unable to write NVM

16-757-67 Unable to write NVM

16-757-93 Unable to set ICS document state

16-758-09 Invalid service failure reported

16-758-14 RPC communications error to client

16-758-19 Unable to Unregister Registration Service

16-758-26 Fault Service: Error trying to access queue ID

Procedure

WARNING

Ensure that the electricity to the machine is switched off while performing tasks that do not need electricity. Disconnect the power cord. Electricity can cause death or injury. Moving parts can cause injury.

Cycle system power. **The error persists.**

Y N
| Perform SCP 6 Final Actions.

Perform GP 9 to reload system software. **The error persists.**

Y N
| Perform SCP 6 Final Actions.

Replace the ESS Board, REP 18.1.98.

16-758-35 to 16-759-26 Service Run Loop Failed

- 16-758-35 Unable to change EJS state to OFF line
- 16-758-46 Registration Monitor Failure
- 16-758-47 Error Finding Job Id
- 16-758-66 ServiceRun loop failed
- 16-758-67 ServiceRun loop failed
- 16-758-93 Unable to obtain data store object handle
- 16-759-09 Unable to map process death
- 16-759-14 Request for wildcard from non-NC
- 16-759-19 NC Failed Cold Reset 3 Times in a Row
- 16-759-26 Unrecognized Service ID requesting Fault Information

Procedure

WARNING

Ensure that the electricity to the machine is switched off while performing tasks that do not need electricity. Disconnect the power cord. Electricity can cause death or injury. Moving parts can cause injury.

Cycle system power. **The error persists.**

Y N
| Perform SCP 6 Final Actions.

Perform GP 9 to reload system software.

16-759-46 to 16-760-46 Fail to Enable Process

- 16-759-46 Failed to disable or enable a process
- 16-759-47 Failed to Abort Process
- 16-759-66 OA event register failed
- 16-759-67 OA event register failed
- 16-759-93 Unable to create .DAT file
- 16-760-09 Scan To File process death
- 16-760-14 Invalid unregister request.
- 16-760-19 NC Initializing
- 16-760-26 Unable to become Client of RDT
- 16-760-46 Processes is in an unknown state

Procedure

WARNING

Ensure that the electricity to the machine is switched off while performing tasks that do not need electricity. Disconnect the power cord. Electricity can cause death or injury. Moving parts can cause injury.

Cycle system power. **The error persists.**

Y N
| Perform SCP 6 Final Actions.

Perform GP 9 to reload system software.

16-760-47 to 16-761-46 File Error

16-760-47 Incorrect Checksum partition 1

16-760-67 Create List Failed

16-760-68 SRS returns invalid or missing data

16-760-93 Job report failure from CCM

16-760-99 Request for system policy failed

16-761-09 LPD process death

16-761-14 Invalid RPC data

16-761-19 NC Shutting Down

16-761-26 Unable to become client of UI

16-761-46 Ethernet status file error

Procedure

WARNING

Ensure that the electricity to the machine is switched off while performing tasks that do not need electricity. Disconnect the power cord. Electricity can cause death or injury. Moving parts can cause injury.

Cycle system power. **The error persists.**

Y N
| Perform SCP 6 Final Actions.

Perform GP 9 to reload system software.

16-761-47 to 16-769-95 Other Network Faults 1

16-761-47 SWVerify Init File failed

16-761-67 Failed to Retrieve Public List

16-761-68 Login gets no response from SRS (No IPC Response?)

16-761-93 Image conversion to TIFF failed

16-761-95 Unable to read template pool

16-762-09 Netware process death

16-762-14 Invalid internal table type

16-762-19 DC Platform Mgr Comm Error

16-762-26 Unable to become client of SCS Diag Service

16-762-46 Token ring status file error

16-762-47 Missing File

16-762-67 Invalid Index for Recipient List

16-762-68 Service Registry Bad data / Corrupted

16-762-93 IFSImageDoneX call failed

16-762-95 Unable to read document repository

16-763-09 NetBios process death

16-763-14 Reached internal limit for events

16-763-19 System Manager Comm Error

16-763-26 No acknowledgment to RPC message. RPC time-out

16-763-46 DHCP status file error

16-763-47 Invalid Permission

16-763-67 Failed to retrieve LDAP list

16-763-93 Document image count not found

16-763-95 Internal destination error

16-764-09 AppleTalk process death

16-764-14 Internal Logic error
16-764-19 Set Up of the SIGALRM Signal failed
16-764-46 RARP status file error
16-764-47 Incorrect Checksum partition 2
16-764-67 Create List Failed
16-765-09 Banyan Vines process death
16-765-19 SystemMgr call failed
16-765-46 Failed to clear SM status
16-765-47 Novell Daemon not running
16-765-67 Failed to Retrieve Recipient List
16-765-93 Unable to access data store
16-766-09 Adobe process failure
16-766-19 DM admin error
16-766-46 Failed to set SM status
16-766-47 No Servers Responded
16-766-67 Failed to Bind to LDAP Server
16-766-93 TIFF handle has become null
16-766-95 Cannot create Image file name
16-767-09 HP PCL process death
16-767-19 Request to cancel spooling job error
16-767-46 Failed to send SESS alert/event
16-767-47 Server in Config list not up
16-767-67 Error performing LDAP search
16-767-93 Get Document Image Count failed
16-767-95 Cannot determine filing policy for transfer
16-768-09 Parallel process death

16-768-19 Hold/release of jobs error
16-768-46 Request had invalid parameters
16-768-47 NC Not Attached to Server
16-768-67 Error performing Public search
16-768-93 Increment image count failed
16-768-95 Cannot get Network advisory lock file name
16-769-09 HTTP process death
16-769-19 Novell Network communications error
16-769-46 Config Methods library error
16-769-47 NC Not Attached to print queue
16-769-67 Failed to Cancel Search Request
16-769-93 IFS deregister call failed
16-769-95 Cannot determine appropriate lock name/address

Procedure

WARNING

Ensure that the electricity to the machine is switched off while performing tasks that do not need electricity. Disconnect the power cord. Electricity can cause death or injury. Moving parts can cause injury.

Cycle system power. **The error persists.**

Y N
| Perform SCP 6 Final Actions.

Perform GP 9 to reload system software.

16-770-09 to 16-779-95 Other Network Faults 2

16-770-09 Unexpected process death

16-770-19 Online/Offline request time out

16-770-46 Cannot register for SESS events

16-770-47 Attached to Queue and Server

16-770-67 Required attribute missing

16-771-09 Print Service EJS process death

16-771-19 Online/Offline callback failure

16-771-46 Internal error with Synchronizer queue

16-771-47 Novell Config Info Failure

16-772-09 NC Print SPI process death

16-772-19 Failure to set NC Platform Manager service state

16-772-46 TCPIP status file error

16-772-47 RPC Failure for communication

16-772-95 Invalid transfer request

16-773-09 NC Print Service Surrogate process death

16-773-19 Unknown client requested online/offline

16-773-46 Failed requesting platform reset

16-774-09 NC Protocol Module process death

16-774-19 Can not obtain RPC connection

16-774-46 BOOTP status file error

16-775-19 Can not obtain Data Store handle for server object

16-775-46 TCPIP missing configuration data

16-775-95 Cannot create temporary file name

16-776-09 NC Fault Service process death

16-776-19 Cannot delete jobs using Job Map library

16-776-46 TCPIP invalid interface

16-776-95 Cannot clean up after job completion

16-777-09 NC Completed Job Log Service/SPI process death

16-777-19 Cannot access Data Store element

16-777-46 TCPIP invalid addressing

16-777-95 Cannot log requested network server

16-778-09 NC Configuration Utility process death

16-778-19 Invalid Enable Demo Job setting

16-778-46 TCPIP socket failure

16-778-95 Cannot generate confirmation sheet

16-779-00 Power Save Complete callback failed

16-779-09 NC Diagnostic Service process death

16-779-19 Power Save Complete callback failed

16-779-46 TCPIP interface attach

16-779-47 SESS IPX test failed on open for send

16-779-95 Cannot create the template/job log name.

Procedure

WARNING

Ensure that the electricity to the machine is switched off while performing tasks that do not need electricity. Disconnect the power cord. Electricity can cause death or injury. Moving parts can cause injury.

Cycle system power. **The error persists.**

Y N
| Perform SCP 6 Final Actions.

Perform GP 9 to reload system software. **The error persists.**

Y N
| Perform SCP 6 Final Actions.

Perform DC361 to backup data, then perform DC301 Network Controller Reinitialization

16-780-00 to 16-789-47 Other Network Faults 3

16-780-00 Power Saver request time out

16-780-09 NC Authentication SPI process death

16-780-19 Power Saver request time out

16-780-46 TCPIP enable interface

16-780-47 SESS IPX test failed on open for receive

16-780-95 Cannot determine the remote directory

16-781-09 NC Counters Utility process death

16-781-19 Network Upgrade Checksum Error

16-781-46 TCPIP NVRAM Failure.

16-781-47 SESS IPX test failed on bind for send

16-782-09 NC Configuration Synchronization process failure

16-782-19 SW Upgrade manifest mismatch

16-782-46 TCPIP Gateway Failure

16-782-47 SESS IPX test failed on bind for receive

16-783-09 Unable to send sc_proc_disable()

16-783-19 NC Failure to enter upgrade mode.

16-783-46 TCPIP host file failure

16-783-47 SESS IPX test send failure

16-784-09 Missing service type

16-784-19 Upgrade aborted - IOT failed to enter Upgrade Mode

16-784-46 TCPIP Resolve File Failure

16-784-47 SESS IPX test receive failure

16-785-09 NC SNMP Agent process failure

16-785-19 Upgrade aborted - UI failed to enter Upgrade Mode

16-785-46 TCPIP Resolve File Failure

16-785-47 SESS IPX test bad data in receive

16-786-09 Token Ring process death

16-786-19 NC failure to uncompress upgrade file

16-786-46 TCPIP ELT File Failure

16-786-47 SESS IPX test unknown error

16-787-09 Sub agent process death

16-787-19 IOT SW Upgrade failed

16-787-46 TCPIP IPC failure

16-787-47 SESS Apple test zip failure - network unreachable

16-788-09 Serial process death

16-788-19 NC PM Failed to install Scan to File

16-788-46 Dynamic DNS status file error

16-788-47 SESS Apple test no zones found

16-789-09 Connectivity Configuration Server process death

16-789-19 NC PM Failed to install LAN FAX

16-789-46 Autonet status file error

16-789-47 SESS Apple test unknown error

Procedure

WARNING

Ensure that the electricity to the machine is switched off while performing tasks that do not need electricity. Disconnect the power cord. Electricity can cause death or injury. Moving parts can cause injury.

Cycle system power. **The error persists.**

Y N
| Perform SCP 6 Final Actions.

Perform GP 9 to reload system software.

16-790-09 to 16-799-47 Other Network Faults 4

16-790-09 Lan Fax process death

16-790-19 NC PM Failed to install Job Based Accounting

16-790-47 SESS Banyan test unknown error

16-791-09 Accounting process death

16-791-19 Scan to File DLM is not defined

16-791-46 DHCP for IPv6 failed. Status code 17-512 is raised for the fault code.

16-791-47 SESS Banyan test no network

16-792-09 Tiff process death

16-792-19 Lan Fax DLM is not defined

16-792-47 SESS Banyan test open failure

16-793-09 Port9100 process death

16-793-19 Job Based Accounting DLM is not defined

16-793-47 SESS Banyan test echo failure

16-794-09 Cross platform synchronization error

16-794-19 Install Password mismatch

16-794-47 SESS Banyan test no servers

16-795-09 Slpsa process death

16-795-19 NC PM Failed to remove LAN FAX

16-795-47 SESS NetBIOS test no lanas found

16-796-09 SSDP process death

16-796-19 NC PM Failed to remove Scan to File

16-796-47 SESS NetBIOS test invalid command

16-797-09 USB process death

16-797-19 NC PM Failed to remove Job Based Accounting

16-797-47 SESS NetBIOS test interface busy

16-798-09 POP3 process death

16-798-19 Option already enabled

16-798-47 SESS NetBIOS test too many commands

16-799-09 SMTP process death

16-799-19 Option already enabled

16-799-47 SESS NetBIOS test invalid adapter

Procedure

WARNING

Ensure that the electricity to the machine is switched off while performing tasks that do not need electricity. Disconnect the power cord. Electricity can cause death or injury. Moving parts can cause injury.

Cycle system power. **The error persists.**

Y N
| Perform SCP 6 Final Actions.

Perform GP 9 to reload system software.

16-800-09 to 16-809-47 Other Network Faults 5

16-800-09 List access failure (create, add, find, delete)

16-800-19 Option not supported

16-800-46 Ethernet Initialization failure

16-800-47 SESS NetBIOS test cannot cancel

16-801-09 Invalid SESS event/IPC error

16-801-19 Serial Number mismatch

16-801-46 Token Ring Initialization failure

16-801-47 SESS NetBIOS test oem x (unusual network problem)

16-802-09 Invalid SESS event/IPC error

16-802-19 Counters do not match

16-802-46 DHCP Initialization failure

16-802-47 SESS NetBIOS test adapter malfunction

16-803-09 Invalid SESS event/IPC error

16-803-46 RARP Initialization failure

16-803-47 SESS NetBIOS test cannot init token ring

16-804-09 Invalid SESS event/IPC error

16-804-47 SESS NetBIOS test no cable connected to board

16-805-09 Invalid SESS event/IPC error

16-805-19 Accounting install failed

16-805-47 SESS NetBIOS test could not join ring

16-806-00 CPI service Death Error

16-806-09 CPI service unavailable

16-806-19 Counters did not increment

16-806-47 SESS NetBIOS test cable not connected to MAU

16-807-00 JobLog Service Death Error

16-807-09 Job log service unavailable

16-807-19 State change failed

16-807-47 SESS NetBIOS test memory allocation error

16-808-00 Job Tracker Service Death Error

16-808-09 Job tracker service unavailable

16-808-47 SESS NetBIOS test no more minor devices available

16-809-00 Kerberos Service Death Error

16-809-09 Kerberos service unavailable

16-809-47 SESS NetBIOS test token ring board was stopped

Procedure

WARNING

Ensure that the electricity to the machine is switched off while performing tasks that do not need electricity. Disconnect the power cord. Electricity can cause death or injury. Moving parts can cause injury.

Cycle system power. **The error persists.**

Y **N**
| Perform SCP 6 Final Actions.

Perform GP 9 to reload system software.

16-810-00 to 16-819-47 Other Network Faults 6

- 16-810-00 Scan To Distribution Service Death Error
- 16-810-09 Scan service unavailable
- 16-810-19 Failed to remove Accounting
- 16-810-47 SESS NetBIOS test network is bad
- 16-811-00 SMB Service Death Error
- 16-811-09 SMB service unavailable
- 16-811-19 Failed to change the enable upgrade flag
- 16-811-47 SESS NetBIOS test command timed out
- 16-812-00 TCP/IP Service Death Error
- 16-812-09 TCPIP service unavailable.
- 16-812-19 Failed to change the enable upgrade flag.
- 16-812-47 SESS NetBIOS test message incomplete
- 16-813-00 WS Scan Temp Service Death Error
- 16-813-09 Scan service unavailable
- 16-813-47 SESS NetBIOS test no resources on local adapter
- 16-814-00 Scan Compressor Service Death Error
- 16-814-09 Scan compressor service unavailable
- 16-814-47 SESS NetBIOS test duplicate name in local name table
- 16-815-09 Service Registry process death
- 16-815-47 SESS NetBIOS test name table is full
- 16-816-09 EIP Service not responding
- 16-816-47 SESS NetBIOS test unexpected protocol received
- 16-817-47 SESS NetBIOS test NetBIOS/ix being reset
- 16-818-47 SESS NetBIOS test NetBIOS/ix being stopped
- 16-819-47 SESS NetBIOS test NetBIOS/ix not loaded

Procedure

WARNING

Ensure that the electricity to the machine is switched off while performing tasks that do not need electricity. Disconnect the power cord. Electricity can cause death or injury. Moving parts can cause injury.

Cycle system power. **The error persists.**

Y **N**
| Perform SCP 6 Final Actions.

Perform GP 9 to reload system software.

16-820-47 to 16-829-47 Other Network Faults 7

16-820-47 SESS NetBIOS test NetBIOS/ix not running

16-821-47 SESS NetBIOS test MAC driver went offline

16-822-47 SESS NetBIOS test error during reset

16-823-47 SESS NetBIOS test unknown error

16-824-47 SESS UNIX test unknown error

16-825-47 Echo Test Failure; SESS diag name not found

16-826-47 SESS Apple test zip failure - system error

16-827-47 SESS Apple test zip failure - invalid parameters

16-828-47 SESS Apple test zip failure - no router found

16-829-47 SESS Apple test zip failure - unknown zip error

Procedure

WARNING

Ensure that the electricity to the machine is switched off while performing tasks that do not need electricity. Disconnect the power cord. Electricity can cause death or injury. Moving parts can cause injury.

Cycle system power. **The error persists.**

Y N
| Perform SCP 6 Final Actions.

Perform GP 9 to reload system software.

16-830-47 to 16-839-47 Other Network Faults 8

16-830-47 GetNetData IP Diagnostic - failed to get default router

16-831-47 GetNetData IP Diagnostic - failed to get subnet mask

16-832-47 GetNetData IP Diagnostic - failed to get local devices

16-833-47 GetNetData IP Diagnostic - failed on ARP

16-834-47 Novell GetNetData - failed getting default file server

16-835-47 Novell GetNetData - failed getting frame type

16-836-47 Novell GetNetData - failed to init netwar

16-837-47 GetNetData - Diagnostic Name not found

16-838-47 SWVerify Setup Alarm Failed

16-839-47 SWVerify Repair Filelength Failed

Procedure

WARNING

Ensure that the electricity to the machine is switched off while performing tasks that do not need electricity. Disconnect the power cord. Electricity can cause death or injury. Moving parts can cause injury.

Cycle system power. **The error persists.**

Y N
| Perform SCP 6 Final Actions.

Perform GP 9 to reload system software.

16-840-47 to 16-849-47 Other Network Faults 9

- 16-840-47 System call failed
- 16-841-47 SWVerify Missing Directory
- 16-842-47 SWVerify Process Not Running
- 16-843-47 SWVerify Repair Timeout
- 16-844-47 Failed to save data to NVM
- 16-845-47 Failed to initialize NVM
- 16-846-47 Failed to restore contents of NVM
- 16-847-47 Failed to write value to NVM
- 16-848-47 Failed to read faults
- 16-849-47 Failed to create command array

Procedure

WARNING

Ensure that the electricity to the machine is switched off while performing tasks that do not need electricity. Disconnect the power cord. Electricity can cause death or injury. Moving parts can cause injury.

Cycle system power. **The error persists.**

Y N
| Perform SCP 6 Final Actions.

Perform GP 9 to reload system software.

16-850-47 to 16-859-47 Other Network Faults 10

- 16-850-47 Failed to add substitution string
- 16-851-47 Failed calling stream editor
- 16-852-47 Failed to process fault for error report
- 16-853-47 Failed to get last reset time
- 16-854-47 Failed on call to fault service
- 16-855-47 Failed on call send event
- 16-856-47 Failed on system command
- 16-857-47 Failed to find process
- 16-858-47 Failed to dump log
- 16-859-47 Failed on software verify

Procedure

WARNING

Ensure that the electricity to the machine is switched off while performing tasks that do not need electricity. Disconnect the power cord. Electricity can cause death or injury. Moving parts can cause injury.

Cycle system power. **The error persists.**

Y N
| Perform SCP 6 Final Actions.

Perform GP 9 to reload system software.

16-860-47 to 16-869-47 Other Network Faults 11

16-860-47 No response for IP Ping Test

16-861-47 Registration Monitor Failure

16-862-47 SESS NETBIOS test invalid cancel command

16-863-47 SESS NETBIOS test illegal buffer length

16-864-47 SESS NETBIOS test illegal local session number

16-865-47 SESS NETBIOS test session closed

16-866-47 SESS NETBIOS test command cancelled

16-867-47 SESS NETBIOS test name deregistered

16-868-47 SESS NETBIOS test local session table full

16-869-47 SESS NETBIOS test no listen in remote computer

Procedure

WARNING

Ensure that the electricity to the machine is switched off while performing tasks that do not need electricity. Disconnect the power cord. Electricity can cause death or injury. Moving parts can cause injury.

Cycle system power. **The error persists.**

Y N
| Perform SCP 6 Final Actions.

Perform GP 9 to reload system software.

16-870-47 to 16-879-47 Other Network Faults 12

16-870-47 SESS NETBIOS test illegal name number

16-871-47 SESS NETBIOS test cannot find name or no answer

16-872-47 SESS NETBIOS test name in use

16-873-47 SESS NETBIOS test name deleted

16-874-47 SESS NETBIOS test session abnormal end

16-875-47 SESS NETBIOS test name conflict

16-876-47 SW verify setup SIGTERM Failed

16-877-47 SESS PCI test unknown error

16-878-47 SESS PCI test failed to open driver

16-879-47 SESS PCI test failed flushing stream buffer

Procedure

WARNING

Ensure that the electricity to the machine is switched off while performing tasks that do not need electricity. Disconnect the power cord. Electricity can cause death or injury. Moving parts can cause injury.

Cycle system power. **The error persists.**

Y N
| Perform SCP 6 Final Actions.

Perform GP 9 to reload system software.

16-880-47 to 16-890-47 Other Network Faults 13

16-880-47 SESS PCI test failed on put msg call

16-881-47 SESS PCI test invalid argument

16-882-47 SESS PCI test failed on put msg call

16-883-47 SESS PCI test failed on ioctl call

16-884-47 SESS PCI test control flag area too small

16-885-47 SESS PCI test driver not initialized

16-886-47 SESS PCI test info request failed

16-887-47 SESS PCI test driver failed to register

16-888-47 SESS PCI test driver failed to unregister

16-889-47 SW verify get data failed

16-890-47 SW verify get next proc failed

Procedure

WARNING

Ensure that the electricity to the machine is switched off while performing tasks that do not need electricity. Disconnect the power cord. Electricity can cause death or injury. Moving parts can cause injury.

Cycle system power. **The error persists.**

Y N
| Perform SCP 6 Final Actions.

Perform GP 9 to reload system software.

16-891-00, 16-892-00 Edge Server Error

16-891-00 Edge server auto registration failed. Status code 17-562 is raised with this fault code.

16-892-00 Edge server communication failed. Status code 17-563 is raised with this fault code.

Procedure

WARNING

Ensure that the electricity to the machine is switched off while performing tasks that do not need electricity. Disconnect the power cord. Electricity can cause death or injury. Moving parts can cause injury.

Cycle system power. **The error persists.**

Y N
| Perform SCP 6 Final Actions.

Perform GP 9 to reload system software.

16-900-19 to 16-909-19 Other Network Faults 14

16-900-19 Failed to open on SMC driver

16-901-19 Failed to make ioctl call using SMC driver

16-902-19 Address specified is invalid

16-903-19 Result from ioctl does not match FD

16-904-19 Invalid ioctl request

16-905-19 Unknown ioctl failure

16-906-19 Malloc failed for net upgrade

16-908-19 Error opening file

16-909-19 Error transfer data to CCM

Procedure

WARNING

Ensure that the electricity to the machine is switched off while performing tasks that do not need electricity. Disconnect the power cord. Electricity can cause death or injury. Moving parts can cause injury.

Cycle system power. **The error persists.**

Y N
| Perform SCP 6 Final Actions.

Perform GP 9 to reload system software.

16-910-19 to 16-919-19 Other Network Faults 15

16-910-19 Failed to untar File

16-911-19 Error changing directory

16-912-19 Install script did not execute

16-913-19 Write failure to file

16-914-19 Shared memory was corrupted

16-915-19 Open failed

16-916-19 CRC Failed

16-917-19 Failed to close on checksum

16-918-19 CRC comparison failed

16-919-19 Restart request failed

Procedure

WARNING

Ensure that the electricity to the machine is switched off while performing tasks that do not need electricity. Disconnect the power cord. Electricity can cause death or injury. Moving parts can cause injury.

Cycle system power. **The error persists.**

Y N
| Perform SCP 6 Final Actions.

Perform GP 9 to reload system software.

16-920-19 to 16-929-19 Other Network Faults 16

16-920-19 ELT Daemon start failed

16-922-19 NVM store failed

16-923-19 Failed saving persistent data

16-924-19 Failed in restoring persistent data

16-925-19 Failed saving web config data

16-926-19 Failed to save data store values

16-927-19 Failed to restore web config data

16-928-19 Failed to install files

16-929-19 Failed to restore data store values

Procedure

WARNING

Ensure that the electricity to the machine is switched off while performing tasks that do not need electricity. Disconnect the power cord. Electricity can cause death or injury. Moving parts can cause injury.

Cycle system power. **The error persists.**

Y N
| Perform SCP 6 Final Actions.

Perform GP 9 to reload system software.

16-930-19 to 16-939-19 Other Network Faults 17

16-930-19 Failed to remove jobs

16-931-19 Failed to close on SMC driver

16-932-19 NVM write failure

16-933-19 Failed to remove file

16-934-19 Job Based Accounting not enough dc memory

16-935-19 Auto-upgrade failed. Cannot read/write attributes to machine.

16-936-19 Auto-upgrade failed. Cannot connect to remote server.

16-937-19 Auto-Upgrade failed Cannot login to remote server

16-938-19 Auto-upgrade failed. Cannot access directory on remote server

16-939-19 Auto-upgrade failed. Multiple upgrade files found on remote server

Procedure

WARNING

Ensure that the electricity to the machine is switched off while performing tasks that do not need electricity. Disconnect the power cord. Electricity can cause death or injury. Moving parts can cause injury.

Cycle system power. **The error persists.**

Y N
| Perform SCP 6 Final Actions.

Check the system software set version, then perform GP 9 to reload system software.

16-940-19 to 16-949-19 Other Network Faults 18

16-940-19 Auto-upgrade failed. Machine is in diagnostics mode.

16-941-19 Auto-Upgrade failed. NC to CCS Coms failure

16-942-19 Auto-Upgrade failed. Upgrade file is invalid

16-943-19 Auto-Upgrade failed. File is invalid. Installed software is more recent

16-944-19 Auto-Upgrade failed. File is invalid. Corruption detected

16-945-19 Auto-Upgrade failed - File not valid for machine

16-946-19 Failed install Scan to Email

16-947-19 Failed to install internet Fax

16-948-19 Remove of Scan to Email option failed

16-949-19 Remove of Internet Fax option failed

Procedure

WARNING

Ensure that the electricity to the machine is switched off while performing tasks that do not need electricity. Disconnect the power cord. Electricity can cause death or injury. Moving parts can cause injury.

Cycle system power. **The error persists.**

Y N
| Perform SCP 6 Final Actions.

Check the system software set version, then perform GP 9 to reload system software.

16-950-19 to 16-959-19 Other Network Faults 19

16-950-19 Scan to email image processing hardware not available

16-951-19 Internet fax image processing hardware not available

16-952-19 Scan to Email memory size error

16-953-19 Internet fax memory size error

16-954-19 Internet Fax Application Registration Error. Status code 17-553 is raised with this fault code.

16-955-19 Internet Fax Application Registration Error. Status code 17-557 is raised with this fault code.

16-956-19 Internet Fax Application Registration Error. Status code 17-554 is raised with this fault code.

16-957-19 Internet Fax Application Registration Error. Status code 17-558 is raised with this fault code.

16-958-19 Failed to install Kerberos.

16-959-19 Failed to install SMB.

Procedure

WARNING

Ensure that the electricity to the machine is switched off while performing tasks that do not need electricity. Disconnect the power cord. Electricity can cause death or injury. Moving parts can cause injury.

Cycle system power. **The error persists.**

Y N
| Perform SCP 6 Final Actions.

Perform GP 9 to reload system software.

16-960-19 to 16-969-19 Other Network Faults 20

16-960-19 Failed to install SMTP

16-961-19 Failed to remove Kerberos.

16-962-19 Failed to remove SMB.

16-963-19 Failed to remove SMTP

16-964-19 Failed to Cancel operation

16-965-19 Failed to send Platform Unavailable

16-966-19 Failed to install job tracker

16-967-19 Failed to remove job tracker

16-968-19 Failed to install POP3

16-969-19 Failed to remove POP3

Procedure

WARNING

Ensure that the electricity to the machine is switched off while performing tasks that do not need electricity. Disconnect the power cord. Electricity can cause death or injury. Moving parts can cause injury.

Cycle system power. **The error persists.**

Y N
| Perform SCP 6 Final Actions.

Perform GP 9 to reload system software.

16-975-19 to 16-979-35 Other Network Faults 21

16-975-19 Failed to install Disk Overwrite

16-976-19 Failed to install Immediate Image Overwrite

16-977-00 Queue List Jobs failure

16-977-19 NC PM failed to remove Disk Overwrite

16-977-35 Queue List Jobs failure

16-978-00 Unable to get copy jobs

16-978-19 NC PM failed to remove Job Overwrite

16-978-35 Unable to get copy jobs

16-979-00 Unknown attribute returned

16-979-19 NC PM failed to remove Embedded Fax

16-979-35 Unknown attribute returned

Procedure

WARNING

Ensure that the electricity to the machine is switched off while performing tasks that do not need electricity. Disconnect the power cord. Electricity can cause death or injury. Moving parts can cause injury.

Cycle system power. **The error persists.**

Y N
| Perform SCP 6 Final Actions.

Perform GP 9 to reload system software.

16-980-00 to 16-989-35 Other Network Faults 22

16-980-00 DM request Handle NULL

16-980-19 NC PM failed to install G4

16-980-35 DM request Handle NULL

16-981-00 Unable to Obtain Job Handle

16-981-35 Unable to Obtain Job Handle

16-982-00 Unknown Finishing Value returned

16-982-19 Failed to remove Embedded Fax

16-982-35 Unknown Finishing Value returned

16-983-00 Unknown Offset value returned

16-983-19 Failed to remove G4

16-983-35 Unknown Offset value returned

16-984-00 Unknown Job State Reason value returned

16-984-35 Unknown Job State Reason value returned

16-985-00 Unknown Medium Type value returned

16-985-19 Workflow Scanning Application Registration Error. Status code 17-554 is raised with this fault code.

16-985-35 Unknown Medium Type value returned

16-986-00 Unknown Collation value returned

16-986-19 Workflow Scanning Application Un-Registration Error. Status code 17-558 is raised with this fault code.

16-986-35 Unknown Collation value returned

16-987-00 Unknown Tray value returned

16-987-19 Server Fax Application Registration Error. Status code 17-551 is raised with this fault code.

16-987-35 Unknown Tray value returned

16-988-00 Unknown signature value returned

16-988-19 Server Fax Application Un-Registration Error. Status code 17-556 is raised with this fault code.

16-988-35 Unknown signature value returned

16-989-00 Unknown Plex Value returned

16-989-19 Disk Encryption operation failed on one or more partitions due to a higher priority operation

16-989-35 Unknown Plex Value returned

Procedure

WARNING

Ensure that the electricity to the machine is switched off while performing tasks that do not need electricity. Disconnect the power cord. Electricity can cause death or injury. Moving parts can cause injury.

Cycle system power. **The error persists.**

Y **N**
| Perform SCP 6 Final Actions.

Perform GP 9 to reload system software.

16-990-00 to 16-999-35 Other Network Faults 23

16-990-00 Promote response from DM received with errors

16-990-35 Promote response from DM received with errors

16-991-00 Request to DM to promote Job Failed

16-991-35 Request to DM to promote Job Failed

16-992-00 Unable to build SESS Job Identifier for promote

16-992-35 Unable to build SESS Job Identifier for promote

16-993-00 Unable to get admin. name from data store for promote

16-993-35 Unable to get admin. name from data store for promote

16-994-00 Cancel response from DM received with errors

16-994-35 Cancel response with errors

16-995-00 Request to DM to Cancel Job Failed

16-995-35 Request to DM to Cancel Job Failed

16-996-00 Warning- Unable to build SESS Job Identifier

16-996-35 Warning- Unable to build SESS Job Identifier

16-997-00 Unable to get admin. name from data store

16-997-35 Unable to get admin. name from data store

16-998-00 Job not set to Released State

16-998-35 Job not set to Released State

16-999-00 Could Not Obtain Job PIN for Authorization

16-999-35 Could Not Obtain Job PIN for Authorization

Procedure

WARNING

Ensure that the electricity to the machine is switched off while performing tasks that do not need electricity. Disconnect the power cord. Electricity can cause death or injury. Moving parts can cause injury.

Cycle system power. The error persists.

Y N
| Perform SCP 6 Final Actions.

A

19-300-00 to 19-310-00 Image Disk (HDD) Failure

19-300-00 Unable to read from Image Disk

19-301-00 Unable to write to Image Disk

19-302-00 Bad Data received from Disk

19-303-00 Unable to Format Image Disk

19-310-00 Disk System capacity fault

NOTE: Status codes 19-511 and 19-512 are raised with these fault codes.

Procedure

WARNING

Ensure that the electricity to the machine is switched off while performing tasks that do not need electricity. Disconnect the power cord. Electricity can cause death or injury. Moving parts can cause injury.

Check that the SATA cable from the ESS Board to the Hard Drive is connected and not damaged. **The cable is good.**

Y N
|
Install a replacement SATA cable.

Check the power harness from the LVPS to the Hard Drive. **The wiring is good.**

Y N
|
Repair the harness as necessary.

Install new components as necessary:

- Hard Drive, REP 18.1.97
- ESS Board, REP 18.1.98

19-401-00, 19-402-00 Out of Memory

19-401-00 Out of Memory - Stress Document

19-402-00 Out of Memory - Stress Job

NOTE: Status code 19-502 is raised with these fault codes.

Initial Actions

Break the print job into smaller files.

Procedure

WARNING

Ensure that the electricity to the machine is switched off while performing tasks that do not need electricity. Disconnect the power cord. Electricity can cause death or injury. Moving parts can cause injury.

If this fault remains for more than five minutes, cycle system power. **The error persists.**

Y N
|
Go to SCP 6 Final Actions.

Perform GP 9 to reload system software.

19-403-00 Out of Memory - Job in EPC

19-403-00 Out of Memory - job in EPC

NOTE: Status code 19-515 is raised with this fault code.

Procedure

WARNING

Ensure that the electricity to the machine is switched off while performing tasks that do not need electricity. Disconnect the power cord. Electricity can cause death or injury. Moving parts can cause injury.

No service action is required. Re-scan the job.

19-409-00 Video Integrity Fault

19-409-00 Video integrity fault

NOTE: Status code 19-514 is raised with this fault code.

Procedure

WARNING

Ensure that the electricity to the machine is switched off while performing tasks that do not need electricity. Disconnect the power cord. Electricity can cause death or injury. Moving parts can cause injury.

Cycle system power, then re-run the job.

19-410-00 to 19-410-13 Image Structure Failure RAP

19-410-00 Mark Output Timeout

19-410-01 Video Decompressor fault

19-410-02 Compress Image timeout

19-410-03 Decompress Image timeout

19-410-04 Merge Image timeout

19-410-05 Rotate Image timeout

19-410-06 Network Input Failure

19-410-07 E-Fax Send/Receive Failure

19-410-08 Scan Input Failure

19-410-09 Byte Count Error

19-410-10 Set Up Too Late

19-410-11 DMA Master Abort

19-410-12 Huffman Error

19-410-13 EOR ERROR

NOTE: Status code 19-510 is raised with -00. 19-505 is raised with the other fault codes listed.

Procedure

WARNING

Ensure that the electricity to the machine is switched off while performing tasks that do not need electricity. Disconnect the power cord. Electricity can cause death or injury. Moving parts can cause injury.

If this fault remains for more than five minutes, cycle system power. **The error persists.**

Y N
| Go to SCP 6 Final Actions.

Perform GP 9 to reload system software.

19-750-00 EPC Memory Size Fault

19-750-00 EPC Memory Size fault

Procedure

WARNING

Ensure that the electricity to the machine is switched off while performing tasks that do not need electricity. Disconnect the power cord. Electricity can cause death or injury. Moving parts can cause injury.

No service action required. Re-run the job.

19-752-00 Image Rotation Config Fault

19-752-00 Image Rotation Config fault

Procedure

WARNING

Ensure that the electricity to the machine is switched off while performing tasks that do not need electricity. Disconnect the power cord. Electricity can cause death or injury. **Moving parts can cause injury.**

Cycle system power, then re-run the job.

19-754-00 Image Disk Config Fault

19-754-00 Image Disk Config fault

Procedure

WARNING

Ensure that the electricity to the machine is switched off while performing tasks that do not need electricity. Disconnect the power cord. Electricity can cause death or injury. **Moving parts can cause injury.**

Cycle system power, then re-run the job. **The error persists.**

Y N

| Go to SCP 6 Final Actions.

Go to 19-300-00 to 19-310-00 Image Disk (HDD) Failure RAP.

19-760-00 Test Patterns are Missing from EPC

19-754-00 Test Patterns are missing from EPC

NOTE: Status code 09-582 is raised with this fault code.

Procedure

WARNING

Ensure that the electricity to the machine is switched off while performing tasks that do not need electricity. Disconnect the power cord. Electricity can cause death or injury. Moving parts can cause injury.

Cycle system power. **The error persists.**

Y **N**
| Go to SCP 6 Final Actions.

Perform GP 9 to reload system software.

20A Fax Troubleshooting Entry

Use this RAP to isolate components which contribute to Fax communications failure.

Initial Actions

- Check that the telephone and Fax line cables are properly connected.
- Use a hand set to dial remote number and listen to dial type, (tone / pulse)
- Check the fault history. Go to the appropriate RAP.
- Check the Fax setup for active features that would inhibit transmission, such as: Delayed start time, Local name and ID are set, Dialing type or junk Fax prevention.

Check the following:

- Fax country setting
- Line setup
- Options
- Dial type setting, tone / pulse.

- Print a Fax Activity Report and check for error codes.

Procedure

WARNING

Ensure that the electricity to the machine is switched off while performing tasks that do not need electricity. Disconnect the power cord. Electricity can cause death or injury. Moving parts can cause injury.

The Fax tab is available

Y N
Go to 20H Fax Tab Not Available.

The printer will send a Fax to all machines.

Y N
The printer will send a fax to some machines.

Y N
Go to 20B Unable To Send A Fax.

Go to 20C Unable To Send A Fax To Some Machines RAP.

The printer will receive a fax from the remote machine.

Y N
Go to 20D Unable To Receive A Fax.

The Fax prints out.

Y N
Go to 20E Fax Will Not Print.

The error is cleared.

Y N
Go to 20G Fax Board Checkout.

The Fax is working correctly. Send a three page test Fax to a known good Fax machine. Print a Protocol Report and check for errors.

20B Unable To Send A Fax

Use this RAP to isolate components which contribute to a send failure.

Initial Actions

- Refer to the 20A Fax Entry RAP and complete all initial actions.

Procedure

WARNING

Ensure that the electricity to the machine is switched off while performing tasks that do not need electricity. Disconnect the power cord. Electricity can cause death or injury. Moving parts can cause injury.

Verify with the customer that analog phone line is operational. Connect a telephone handset into line outlet and listen for a dial tone. Use a known good telephone handset. **The dial tone is present.**

Y N
Use the line test tool to check the telephone line. **The green normal indicator light is on.**

Y N
Ask the customer to request a line check by the telephone company.

Use a telephone handset to dial a known good number. **The ring back is heard.**

Y N
Ask the customer to request a line check by the telephone company.

Enable audio line monitor and set to Enable and High volume.

Dial the Fax number and listen for a dial tone or dialing and answer tones. **A Fax tone is present.**

Y N
Enter dC131 NVM Read / Write. Reset the value at the following location:

NVM ID 200-415 Line1CurrentDetect = 0

NVM ID 200-416 Line2CurrentDetect = 0 **A Fax tone is present.**

Y N
Go to the 20F Fax Board Checkout.
Install new components as necessary:

- Fax Board, REP 18.1.7
- Telephone cable

The Fax is working correctly. Send a three page test Fax to a known good Fax machine. Enter Admin / Tools / Service Settings / Embedded Fax Setting / Print Fax Reports. Print a Protocol Report and check for errors.

The dial tone - dialling answer tones are present.

Y N
The exchange is receiving the digits too quickly or is not processing the digits correctly. Ask the customer if the exchange is DTMF (Dual Tone Multiple Frequency) or pulse dialing.

Perform the following:

- Ensure the printer is set for the correct dialing tone.

A B

Enter dC131 NVM Read / Write. Reset the values at NVM ID 200-201 FaxLine1DialTypeDef and at NVM ID 200-202 FaxLine2DialTypeDef set to 0 = Tone or 1 = Pulse.

- Insert a pause (,) between the first and second digit of the dial string. In the Dialling Options select Dialling Characters / Pause / Add Character / Save.

The Fax only dials once and hangs up or the busy tone has unusual timing, frequency or level. **The busy tones are recognized.**

Y N

Check the number for a voice or tone answer.

The Fax is working correctly. Send a three page test Fax to a known good Fax machine. Enter Admin / Tools / Service Settings / Embedded Fax Setting / Print Fax Reports. Print a Protocol Report and check for errors. Re-enter the details from the fax options

Check that the customer is dialing the correct number. **The number is correct.**

Y N

Ask the customer to dial the number using the appropriate access codes.

Enable audio line monitor (Enter Admin / Tools / Service Settings / Embedded Fax Setting / Transmission Defaults / Audio Line Monitor) and set to Enable. Select High volume and max time.

Dial the Fax number and listen for a dial tone or dialing and answer tones. **A Fax tone is present.**

Y N

Enter dC131 NVM Read / Write. Reset the value at the following location:
NVM ID 200-415 Line1CurrentDetect = 0
NVM ID 200-416 Line2CurrentDetect = 0 **A Fax tone is present.**

Y N

Go to the 20F Fax Board Checkout.
Install new components as necessary:

- Fax Board, REP 18.1.7.
- Telephone cable

The Fax is working correctly. Send a three page test Fax to a known good Fax machine. Enter Admin / Tools / Service Settings / Embedded Fax Setting / Print Fax Reports. Print a Protocol Report and check for errors.

The dial tone - dialling answer tones are present.

Y N

The exchange is receiving the digits too quickly or is not processing the digits correctly. Ask the customer if the exchange is DTMF (Dual Tone Multiple Frequency) or pulse dialing.

Perform the following:

- Ensure that the machine is set for the correct dialing tone.
Enter dC131 NVM Read / Write. Reset the values at NVM ID 200-201 FaxLine1DialTypeDef and at NVM ID 200-202 FaxLine2DialTypeDef set to 0 = Tone or 1 = Pulse.
- Insert a pause (,) between the first and second digit of the dial string. In the Dialling Options select Dialling Characters / Pause / Add Character / Save.

C

- Enter dC131 NVM Read / Write. Set NVM ID 200-397 FaxTimeBeforeDial to 13.

The Fax only dials once and hangs up or the busy tone has unusual timing, frequency or level.

Are the busy tones recognized.

Y N

- Check the number for a voice or tone answer.
- Check that the values at NVM ID 200-237 to 200-241 are set to the correct defaults to match the appropriate country setting.

The fax is working correctly. Send a three page test Fax to a known good Fax machine. Print a Protocol Report and check for errors. Re-enter the details from the fax options.

C

20C Unable To Send A Fax To Some Machines

Use this RAP to isolate components which contribute to a failure to send a Fax to some machines.

Initial Actions

- Refer to the 20A Fax Entry RAP and complete all of the initial actions.

Procedure

WARNING

Ensure that the electricity to the machine is switched off while performing tasks that do not need electricity. Disconnect the power cord. Electricity can cause death or injury. Moving parts can cause injury.

The correct number is being dialled to make the connection. **The connection is made.**

Y N

The exchange is not processing the digits correctly, the machine needs longer pause between digits.

- Insert a pause (,) between the first and second digit of the dial string. In the Dialling Options select Dialling Characters / Pause / Add Character / Save.
- Enter dC131 NVM Read / Write. Change setting at NVM ID 200-410 FaxDTMFTone-Time to 100.

Call the fax number from a known good telephone and listen for the answer fax tone. **The Fax tone is heard.**

Y N

Fax on remote end is not picking up or no Fax is connected. Advise customer to check the machine at the remote end.

Print a Protocol Report. The Protocol Report shows RNR (Receive Not Ready) is received from the remote Fax repeatedly until time out and DCN (Disconnect). Check communication failure after V34-PH2 / V34-PH3 or DCS / TCF. **The remote Fax receives and prints the Fax.**

Y N

Compatibility problem with remote Fax.

- Print a Protocol Report and check for communication errors.
- Line quality too poor for Super G3 to function correctly. Possible mains interference on line.
- Disable V34 (Super G3). Enter dC131 NVM Read / Write. Reset the value at the following locations:
 - NVM ID 200-087 T30MaxSpeedL1Tx = 11 (14400).
 - NVM ID 200-088 T30MaxSpeedL2Tx = 11 (14400).
- When sending to a PC fax or fax server that has an ISDN card, there is a need to customize the CEQ values. Enter dC131 NVM Read / Write. Set the value at NVM ID 203-031 to 0.

The Protocol Report shows MCF (Message Confirmation) is not sent by the remote Fax (last page), only DCN (Disconnect). **The failure report printed out, but the remote fax prints multiple copies of the job or failed page.**

Y N

The Fax is working correctly. Send a three page test Fax to a known good Fax machine. Print a Protocol Report and check for errors.

The machine will resend up to 10 times before printing the failure report. Set number of resends to 1 or 2.

20D Unable To Receive A Fax

Use this RAP to isolate components which contribute to the fax not received from the machine.

Initial Actions

- Refer to the 20A Fax Entry RAP and complete all of the initial actions.

Procedure

WARNING

Ensure that the electricity to the machine is switched off while performing tasks that do not need electricity. Disconnect the power cord. Electricity can cause death or injury. Moving parts can cause injury.

Verify with the customer that analog phone line is operational. Use a known good telephone handset or use the line test tool to check the telephone line. **The dial tone is present.**

Y N

- Ask the customer to request a line check by the telephone company.
- Ensure Fax service is enabled and supported on that line by a PBX administrator.

Call the handset from another telephone. **The phone rings.**

Y N

- Ask the customer to request a line check by the telephone company.
- Ensure Fax service is enabled and supported on that line by a PBX administrator.

Enable audio line monitor and set to Enable and High volume.

Dial the Fax number and listen for a dial tone or dialing and answer tones. **A Fax tone is present.**

Y N

- Go to 20G Embedded Fax Checkout
- Install new components as necessary:
 - Fax Board, REP 18.1.7
 - Telephone cable

Reconnect the fax and call the fax number from a independent telephone line and listen for a Fax tone. **The machine answers and a fax tone is heard.**

Y N

- Print an Activity Report. Check for receive calls on the Activity Report. Machine probably does not bleep to indicate incoming call.
- Check that the NVM values at NVM ID 200-203, NVM ID 200-423 and 200-426 are set to the correct defaults to match the appropriate country setting. **The machine answers and a Fax tone is heard.**

Y N

- Go to 20G Fax Board Checkout
- Install new components as necessary:
 - Fax Board, REP 18.1.7

The Fax is working correctly. Send a three page test Fax to a known good Fax machine. Print a Protocol Report and check for errors.

A

Receive a three page test Fax from the original Fax machine. Print a Protocol Report and check for errors. **The Protocol Report shows communication failure after CSI / DIS (Called Subscriber Identified / Digital Identification Signal) or DCS / TCF (Digital Command Signal / Training Check) or after V34-PH2 / V34-PH3 or EQM (Eye Quality Monitor) value greater than 5000.**

Y N

The problem may be intermittent, inform the operator of the remote machine, they should report the problem to the telephone company.

Perform the following:

- Confirm line is standard PSTN / PBX analogue line
- Line quality too poor for Super G3 or G3 to function correctly. Possible mains interference on line. Possible DSL line, not properly filtered.
- Ask customer to request Fax capable service from telephone company.
- If mains noise, install a new Fax Board, REP 18.1.7. Use line 1.
- Enter dC131 NVM Read / Write. Set the value at the following locations:
 - NVM ID 200-085 T30 Maximum resolution Line 1 Rx = 7
 - NVM ID 200-086 T30 Maximum resolution Line 2 Rx = 7This sets the receive resolution capabilities for line 1 and line 2 to 400 x 400 max, this will shorten the DIS.
- The DIS field is too long to enable successful communication. Enter dC131 NVM Read / Write. Change NVM ID 200-141 USSTOCKSUPPORTRAX to 0 (disable).
- Disable V34 (Super G3). Enter dC131 NVM Read / Write and reset the value at the following locations:
 - NVM ID 200-089 T30MaxSpeedL1Rx = 11 (14400)
 - NVM ID 200-090 T30MaxSpeedL2Rx = 11 (14400)If the problem still exists try a lower line receive (Rx) speed: 12 = 12000, 13 = 9600, 14 = 7200, 15 = 4800, 16 = 2400
- Send a three page test Fax from a known good fax machine.

A

20E Fax Will Not Print

Use this RAP to solve Fax printing problems.

Initial Actions

- Check the condition of the media in all trays.
- Check that the trays are loaded with the appropriate media for printing the Fax.

Procedure

WARNING

Ensure that the electricity to the machine is switched off while performing tasks that do not need electricity. Disconnect the power cord. Electricity can cause death or injury. Moving parts can cause injury.

- If the received Fax has mixed size documents (example, the first prints are 8.5 x 11 and then followed by 8.5 x 14 prints). Check in the 'All Incomplete Jobs' queue, the job will print 8.5 x 11 pages without printing 8.5 x 14 pages and then the job will be deleted.

Perform the following:

In Tools menu, go to Fax setup and select:

- Receive Defaults.
- Receive Printing mode and change to Manual.
- In paper sizes, select correct page for each size to match the paper in the tray.
- Save and then change back to Auto. Save and Exit.

- If prompted for a size paper that is not loaded in trays.

Perform the following:

In Tools menu, go to Fax setup and select:

- Receive Defaults.
- Receive Printing mode.
- Select manual, change small paper setting to None and Save.

NOTE: For small, long and large paper sizes select NONE if the corresponding paper is not loaded in the paper trays.

- Change setting to Auto and Save.

20F Fax Board Checkout

Use this RAP to check for problems with the Fax Board.

Initial Actions

- Cycle system power
- Check that the Fax Board is correctly grounded.

Procedure

WARNING

Ensure that the electricity to the machine is switched off while performing tasks that do not need electricity. Disconnect the power cord. Electricity can cause death or injury. Moving parts can cause injury.

Check for +5V from the USB port. **The voltage is good.**

Y N

Install a new components as required.

- USB cable
- ESS Board, REP 18.1.98

Install new components as necessary:

- Fax Board, REP 18.1.7
- ESS Board, REP 18.1.98.

Switch on the machine. **The fault is cleared.**

Y N

Return to the original fault code RAP and perform the remaining actions in the procedure.

Go to SCP 6 and perform the final actions.

20G Fax Problems on Digital Networks

Use this RAP to isolate the problem when using digital networks.

The Fax option was designed as an analog Group 3 device. This will have the best performance when connected to a dedicated analog phone PSTN (Public Switched Telephone Network) line or POTS (Plain Old Telephone system).

- The Fax option will function on the following technologies:
 - ADSL - Asymmetric Digital Subscriber Line
 - DSL - Digital Subscriber Line
 - VOIP - Voice Over Internet Protocol
 - FOIP - Fax Over Internet Protocol, (T.38 protocol).
 - T1 Trunk / E1 Trunk (Europe).

NOTE: Due to the compression used on these technologies. The level of performance will be lower than on a PSTN or POTS.

- The Fax option will not function on the following technology:
 - ISDN - Integrated Services Digital Network

Initial Actions

- Cycle system power.
- Check with the customer or IT person on what network the Fax service is being used and what is the quality of service.
- Check that an analogue adapter or a connection for analogue terminals is available.
- Ask the customer to check with service provider that an analogue port for Fax service has been provided and enabled.

Procedure

WARNING

Ensure that the electricity to the machine is switched off while performing tasks that do not need electricity. Disconnect the power cord. Electricity can cause death or injury. Moving parts can cause injury.

Perform the steps that follow:

- Go to 20A Fax Entry RAP.
- Request the latest SPAR release.
- Disable V34.
 - Enter dC131 NVM Read / Write and reset the value at the following locations:
 - NVM ID 200-087 T30MaxSpeedL1Tx = 11 (14400)
 - NVM ID 200-088 T30MaxSpeedL2Tx = 11 (14400)
 - NVM ID 200-089 T30MaxSpeedL1Rx = 11 (14400)
 - NVM ID 200-090 T30MaxSpeedL2Rx = 11 (14400)
 - NVM ID 203-105 V34toV21FallbackTime = 20

- If problems are still not resolved after these actions, then escalate the problem using the normal escalation process

20H Fax Tab Not Available RAP

Use this RAP to isolate the problem when the Fax service is not available or greyed out.

Initial Actions

- Cycle system power.
- Check Fax Board installation.

Procedure

WARNING

Ensure that the electricity to the machine is switched off while performing tasks that do not need electricity. Disconnect the power cord. Electricity can cause death or injury. Moving parts can cause injury.

The Fax tab is displayed on the Control Panel.

Y N

The fax installation was not completed.

Go to Fax Setup. Select Enable and Save. Cycle system power. This will initiate the 'Fax Install Wizard' and follow the prompts on the screen to complete the install of the Fax.

The Fax tab is displayed after installation.

Y N

Check that the Fax Board is installed correctly, REP 18.1.7.

Perform the following:

1. Cycle system power.
2. Check the connection between the Fax Board and ESS Board.
3. Switch on the printer.

The super fine tab is displayed.

Y N

The Server Fax may be enabled.

Go to Admin / Tools / Service Setting / Embedded Fax Setting / Fax Setup and press Disable and Save. This will disable the Server Fax.

After installing Fax Module. The Fax selection tab is greyed out and requesting a pass code to enable the Fax (Scan to E-mail installed).

Y N

The fax is installed correctly. Send a three page test fax to a known good fax machine. Enter Admin / Tools / Service Settings / Embedded Fax Setting / Print Fax Reports. Print a Protocol Report and check for errors.

Reload system software with the AltBoot procedure, GP 9.

NOTE: Software should only be loaded on a working machine. Loading or reloading software onto a machine (or fax card) that has a fault will not work.

20-302-00 to 20-305-00 Fax Board Hardware or Software Error

The Fax Board will automatically reset.

20-302-00 Fax Card Hardware or Software error

20-303-00 Fax Card Hardware or Software error

20-305-00 Fax Card Hardware or Software error

Initial Actions

- Backup the phone book and customer settings, refer to dC361 Save and Restore.

Procedure

WARNING

Ensure that the electricity to the machine is switched off while performing tasks that do not need electricity. Disconnect the power cord. Electricity can cause death or injury. Moving parts can cause injury.

Cycle system power. **The error persists.**

Y N
| Go to SCP 6 and complete the Final Actions.

Clear Fax NVM. Go to dC301 NVM Initialization, select Embedded Fax NVM initialization and perform the routine, All Data. **The error persists.**

Y N
| Go to SCP 6 and complete the Final Actions.

Perform GP 9 to reload system software. **The error persists.**

Y N
| Go to SCP 6 and complete the Final Actions.

Go to 20F Fax Board Checkout.

20-320-00 Fax Fault Not Cleared by Card Reset

20-320-00 5 instances of unrecoverable fax fault not cleared by card reset

NOTE: Status code 20-559 is raised with this fault code.

Initial Actions

- Backup the phone book and customer settings, refer to dC361 Save and Restore.

Procedure

WARNING

Ensure that the electricity to the machine is switched off while performing tasks that do not need electricity. Disconnect the power cord. Electricity can cause death or injury. Moving parts can cause injury.

Cycle system power. **The error persists.**

Y N
| Go to SCP 6 and complete the Final Actions.

Clear Fax NVM. Go to dC301 NVM Initialization, select Embedded Fax NVM initialization and perform the routine, All Data. **The error persists.**

Y N
| Go to SCP 6 and complete the Final Actions.

Perform GP 9 to reload system software.

20-322-00 NV Device Not Fitted to Basic Fax Card

20-322-00 NV device not fitted to basic fax card

NOTE: Status code 20-558 is raised with this fault code.

Initial Actions

- Backup the phone book and customer settings, refer to dC361 Save and Restore.

Procedure

WARNING

Ensure that the electricity to the machine is switched off while performing tasks that do not need electricity. Disconnect the power cord. Electricity can cause death or injury. Moving parts can cause injury.

Cycle system power. **The error persists.**

Y N
| Go to SCP 6 and complete the Final Actions.

Clear Fax NVM. Go to dC301 NVM Initialization, select Embedded Fax NVM initialization and perform the routine, All Data. **The error persists.**

Y N
| Go to SCP 6 and complete the Final Actions.

Install new parts as necessary:

- Fax Board, REP 18.1.7

20-323-00, 20-324-00 Fax System Memory is Low

20-323-00 Fax system memory is low

NOTE: Status code 20-547 is raised with this fault code.

20-324-00 Not enough memory to use Fax Service

NOTE: Status code 20-546 is raised with this fault code.

Initial Actions

- Backup the phone book and customer settings, refer to dC361 Save and Restore.
- Delete saved Fax documents.

Procedure

WARNING

Ensure that the electricity to the machine is switched off while performing tasks that do not need electricity. Disconnect the power cord. Electricity can cause death or injury. Moving parts can cause injury.

Cycle system power. **The error persists.**

Y N
| Go to SCP 6 and complete the Final Actions.

Clear Fax NVM. Go to dC301 NVM Initialization, select Embedded Fax NVM initialization and perform the routine, All Data. **The error persists.**

Y N
| Go to SCP 6 and complete the Final Actions.

Install new parts as necessary:

- Fax Board, REP 18.1.7

20-327-00 Registers Cannot be Accessed on Extended Card

20-327-00 Registers cannot be accessed on the Extended card

NOTE: Status code 20-570 is raised with this fault code.

Initial Actions

- Backup the phone book and customer settings, refer to dC361 Save and Restore.

Procedure

WARNING

Ensure that the electricity to the machine is switched off while performing tasks that do not need electricity. Disconnect the power cord. Electricity can cause death or injury. Moving parts can cause injury.

Cycle system power. **The error persists.**

Y N
| Go to SCP 6 and complete the Final Actions.

Clear Fax NVM. Go to dC301 NVM Initialization, select Embedded Fax NVM initialization and perform the routine, All Data. **The error persists.**

Y N
| Go to SCP 6 and complete the Final Actions.

Install new parts as necessary:

- Fax Board, REP 18.1.7

20-331-00 to 20-341-00 Fax Network Line 1 Fault

20-331-00 No comms via PSTN1 port. Status code 20-562 is raised with this fault code

20-332-00 No comms via PSTN2 port. Status code 20-563 is raised with this fault code

20-338-00 Fax communication error at power up or re-boot. Status code 20-549 is raised with this fault code.

20-339-00 Fax Card Internal Fault. Status code 20-571 is raised with this fault code.

20-340-00 FaxPort2ModemFailure. Status code 20-572 is raised with this fault code.

20-341-00 Miscellaneous Basic Card problems. Status code 20-547 is raised with this fault code

Initial Actions

- Backup the phone book and customer settings, refer to dC361 Save and Restore.

Procedure

WARNING

Ensure that the electricity to the machine is switched off while performing tasks that do not need electricity. Disconnect the power cord. Electricity can cause death or injury. Moving parts can cause injury.

Cycle system power. **The error persists.**

Y N
| Go to SCP 6 and complete the Final Actions.

Check the connection between the Fax and ESS Boards, REP 18.1.7. **The connection is good.**

Y N
| Repair the connection.

Check the phone line. Plug a phone into the line and check for a dial tone. If a phone is not available then use a line test tool. **The phone line connection is good.**

Y N
| Inform the customer to have the line checked by the telephone company.

Install new parts as necessary:

- Telephone cable
- Fax Board, REP 18.1.7
- ESS Board, REP 18.1.98

20-342-00 Error Accessing File on a NV Device

20-342-00 Error accessing file on a NV device

NOTE: Status code 20-570 is raised with this fault code.

Initial Actions

- Backup the phone book and customer settings, refer to dC361 Save and Restore.

Procedure

WARNING

Ensure that the electricity to the machine is switched off while performing tasks that do not need electricity. Disconnect the power cord. Electricity can cause death or injury. Moving parts can cause injury.

Cycle system power. **The error persists.**

Y N
| Go to SCP 6 and complete the Final Actions.

Clear Fax NVM. Go to dC301 NVM Initialization, select Embedded Fax NVM initialization and perform the routine, All Data. **The error persists.**

Y N
| Go to SCP 6 and complete the Final Actions.

Perform GP 9 to reload system software.

20-345-00 FaxPort1 Modem Failure

20-345-00 FaxPort1ModemFailure

NOTE: Status code 20-595 is raised with this fault code.

Initial Actions

- Backup the phone book and customer settings, refer to dC361 Save and Restore.

Procedure

WARNING

Ensure that the electricity to the machine is switched off while performing tasks that do not need electricity. Disconnect the power cord. Electricity can cause death or injury. Moving parts can cause injury.

Cycle system power. **The error persists.**

Y N
| Go to SCP 6 and complete the Final Actions.

Reseat USB connections between the Fax and ESS Boards. **The error persists.**

Y N
| Go to SCP 6 and complete the Final Actions.

Clear Fax NVM. Go to dC301 NVM Initialization, select Embedded Fax NVM initialization and perform the routine, All Data. **The error persists.**

Y N
| Go to SCP 6 and complete the Final Actions.

Perform GP 9 to reload system software.

20-701-00 Phonebook Download Failed

20-701-00 Phonebook download failed

Initial Actions

- Check that the Fax Board is correctly grounded.

Procedure

WARNING

Ensure that the electricity to the machine is switched off while performing tasks that do not need electricity. Disconnect the power cord. Electricity can cause death or injury. Moving parts can cause injury.

Perform GP 9 to reload system software. **The error persists.**

Y N
| Go to SCP 6 and complete the Final Actions.

Reseat USB connections between the Fax and ESS Boards. **The error persists.**

Y N
| Go to SCP 6 and complete the Final Actions.

Clear Fax NVM. Go to dC301 NVM Initialization, select Embedded Fax NVM initialization and perform the routine, All Data. **The error persists.**

Y N
| Go to SCP 6 and complete the Final Actions.

Install a new ESS Board, REP 18.1.98.

20-710-00, 20-711-00 Fax Card Overwrite Errors

20-710-00 IIO Error occurred on fax card when overwriting the job

20-711-00 ODIO Error on fax card when overwriting compact flash memory

NOTE: Status code 19-506 is raised with these fault codes.

Initial Actions

- Check that the Fax Board is correctly grounded.

Procedure

WARNING

Ensure that the electricity to the machine is switched off while performing tasks that do not need electricity. Disconnect the power cord. Electricity can cause death or injury. Moving parts can cause injury.

Cycle system power. **The error persists.**

Y N
| Go to SCP 6 and complete the Final Actions.

Reseat USB connections between the Fax and ESS Boards. **The error persists.**

Y N
| Go to SCP 6 and complete the Final Actions.

Install new parts as necessary:

- Fax Board, REP 18.1.7

22-300-05 to 22-309-04 Other Network Faults 24

22-300-05 Image Complete fault

22-300-10 DVMA Transfer fault

22-300-16 Clock overflow fault. Status code 03-561 is raised with this fault code

22-301-05 Scan resource fault

22-309-04 No Accepts received fault. Five consecutive 22-309-04 will cause 22-319-04.

Procedure

WARNING

Ensure that the electricity to the machine is switched off while performing tasks that do not need electricity. Disconnect the power cord. Electricity can cause death or injury. Moving parts can cause injury.

Cycle system power. The error persists.

Y N
| Go to SCP 6 and complete the Final Actions.

Perform GP 9 to reload system software.

22-310-04 to 22-318-04 Other Network Faults 25 RAP

22-310-04 Extended Job Service fault

22-311-04 Sequencer response fault

22-314-04 Module Registration Error

22-315-04 Module completion fault. Status code 22-503 is raised with this fault code.

22-316-04 Job Paper Tray fault. Status code 22-504 is raised with this fault code.

22-317-04 Job Finishing fault

22-318-04 Job IOT fault

Procedure

WARNING

Ensure that the electricity to the machine is switched off while performing tasks that do not need electricity. Disconnect the power cord. Electricity can cause death or injury. Moving parts can cause injury.

Cycle system power. The error persists.

Y N
| Go to SCP 6 and complete the Final Actions.

Perform GP 9 to reload system software.

22-319-04 IOT Integrity Problem While Printing a Job

22-319-04 IOT Integrity problem while printing a job

This fault can result in two ways:

1. IOT cycles down and back up 10 times without printing a page within the same job causing a 22-319-04.
2. 5 consecutive 22-309-04 will also cause a 22-319-04. Refer to 22-309-04 for more information.

Procedure

WARNING

Ensure that the electricity to the machine is switched off while performing tasks that do not need electricity. Disconnect the power cord. Electricity can cause death or injury. Moving parts can cause injury.

Cycle system power. **The error persists.**

Y N
| Go to SCP 6 and complete the Final Actions.

Check power is supplied directly from a wall outlet and the outlet provides adequate power.

Power is OK.

Y N
| Connect the printer to an adequate power source.

Perform GP 9 to reload system software.

22-320-00, 22-321-00 Scan to File Fault

22-320-00 Scan to File install fault

22-321-00 Scan to File remove fault

Initial Actions

Check Scan to file is correctly configured.

Procedure

WARNING

Ensure that the electricity to the machine is switched off while performing tasks that do not need electricity. Disconnect the power cord. Electricity can cause death or injury. Moving parts can cause injury.

Cycle system power. **The error persists.**

Y N
| Go to SCP 6 and complete the Final Actions.

Perform GP 9 to reload system software.

22-321-04 RS422I ResponseTimeOutError

22-321-04 RS422I ResponseTimeOutError (Config Mismatch)

NOTE: Status code 22-501 is raised with this fault code.

Initial Actions

- Check machine configuration.

Procedure

WARNING

Ensure that the electricity to the machine is switched off while performing tasks that do not need electricity. Disconnect the power cord. Electricity can cause death or injury. Moving parts can cause injury.

Cycle system power. **The error persists.**

Y N
| Go to SCP 6 and complete the Final Actions.

Perform GP 9 to reload system software.

22-323-00 to 22-327-00 Service Faults

22-323-00 LAN FAX remove fault

22-324-00 Scan to Email install fault

22-325-00 Scan to Email remove fault

22-326-00 IFAX install Fault

22-327-00 IFAX remove Fault

Procedure

WARNING

Ensure that the electricity to the machine is switched off while performing tasks that do not need electricity. Disconnect the power cord. Electricity can cause death or injury. Moving parts can cause injury.

Cycle system power. **The error persists.**

Y N
| Go to SCP 6 and complete the Final Actions.

Perform GP 9 to reload system software.

22-328-00 Incomplete System Information

22-328-00 Incomplete System Information. Accounting Service Data is corrup

NOTE: Status code 22-564 is raised with this fault code.

Procedure

WARNING

Ensure that the electricity to the machine is switched off while performing tasks that do not need electricity. Disconnect the power cord. Electricity can cause death or injury. Moving parts can cause injury.

Cycle system power. **The error persists.**

Y **N**
| Go to SCP 6 and complete the Final Actions.

Perform GP 9 to reload system software.

22-330-00 Supplies Plan Activation Code Entry Locked

22-330-00 Supplies Plan Activation Code entry locked; too many attempts

Procedure

WARNING

Ensure that the electricity to the machine is switched off while performing tasks that do not need electricity. Disconnect the power cord. Electricity can cause death or injury. Moving parts can cause injury.

Cycle system power. **The error persists.**

Y **N**
| Go to SCP 6 and complete the Final Actions.

Obtain a new PIN and try again in 24 hours.

22-330-01 to 22-332-00 Queue Timed Out

22-330-01 List Jobs Request Timed out between UI and CCS

22-330-02 Queue to NC print Timeout

22-330-03 Queue to Scan to file Timeout

22-330-04 Queue to FaxSend Timeout

22-330-05 Queue to DC JOB service Timeout

22-330-06 Queue to Scan to distribution Timeout

22-332-00 Plan Conversion entry locked; too many attempts

Procedure

WARNING

Ensure that the electricity to the machine is switched off while performing tasks that do not need electricity. Disconnect the power cord. Electricity can cause death or injury. Moving parts can cause injury.

Cycle system power. **The error persists.**

Y N

Go to SCP 6 and complete the Final Actions.

Perform GP 9 to reload system software.

22-335-00 to 22-340-00 Service Faults

22-335-00 JBA install fault

22-336-00 JBA Remove Fault

22-337-00 ODIO install fault

22-338-00 ODIO remove fault

22-339-00 IIO install fault

22-340-00 IIO remove fault

Procedure

WARNING

Ensure that the electricity to the machine is switched off while performing tasks that do not need electricity. Disconnect the power cord. Electricity can cause death or injury. Moving parts can cause injury.

Cycle system power. **The error persists.**

Y N

Go to SCP 6 and complete the Final Actions.

Perform GP 9 to reload system software.

22-350-01, 22-350-02 Software Detects Non-Valid Xerox SOK

22-350-01 Software detected non-valid Xerox software option key 1

22-350-02 Software detected non-valid Xerox software option key 2 or 3

Procedure

WARNING

Ensure that the electricity to the machine is switched off while performing tasks that do not need electricity. Disconnect the power cord. Electricity can cause death or injury. Moving parts can cause injury.

Cycle system power. **The error persists.**

Y N
| Go to SCP 6 and complete the Final Actions.

Ignore all requested options from the software option key (SOK).

22-351-01 to 22-351-03 SOK Write Failure

22-351-01 software option key 1 Write Failure

22-351-02 software option key 2 Write Failure

22-351-03 software option key 3 Write Failure

Procedure

WARNING

Ensure that the electricity to the machine is switched off while performing tasks that do not need electricity. Disconnect the power cord. Electricity can cause death or injury. Moving parts can cause injury.

Cycle system power. **The error persists.**

Y N
| Go to SCP 6 and complete the Final Actions.

Ignore all requested options from the software option key (SOK).

22-352-00, 22-352-01 Serial Number Lost/Missing

22-352-00 Serial number lost/missing. A password routine may be required to write serial number to machine.

22-352-01 Password routine required to write serial number to machine.

NOTE: Status code 22-557 is raised with these fault codes.

Initial Actions

NOTE: The SD Card is also referred to as the product enablement key.

- Check that the SD Card is present and fully inserted in the ESS Board.
- Check fault history for 03-xxx fault codes. Go to the appropriate RAP.

Procedure

WARNING

Ensure that the electricity to the machine is switched off while performing tasks that do not need electricity. Disconnect the power cord. Electricity can cause death or injury. Moving parts can cause injury.

Check the serial number reported on the Control Panel matches the chassis label. **The numbers are different.**

Y N
| Go to SCP 6 and complete the Final Actions.

Cycle system power. **The error persists.**

Y N
| Go to SCP 6 and complete the Final Actions.

Use dC132 to restore the serial number.

22-360-00 Service Plan Inconsistent

22-360-00 Service plan inconsistent. A password routine may be required to write service plan/region to machine.

NOTE: Status code 22-581 is raised with these fault codes.

Procedure

WARNING

Ensure that the electricity to the machine is switched off while performing tasks that do not need electricity. Disconnect the power cord. Electricity can cause death or injury. Moving parts can cause injury.

Cycle system power. **The error persists.**

Y N
| Go to SCP 6 and complete the Final Actions.

Install hardware removed before fault was raised. **The error persists.**

Y N
| Go to SCP 6 and complete the Final Actions.

Recover using SD Card (PagePack only).

22-370-00 Unable to Communicate with XSA Database

22-370-00 Unable to communicate with XSA database

NOTE: Status code 22-562 is raised with this fault code.

Procedure

WARNING

Ensure that the electricity to the machine is switched off while performing tasks that do not need electricity. Disconnect the power cord. Electricity can cause death or injury. Moving parts can cause injury.

Cycle system power. **The error persists.**

Y **N**
| Go to SCP 6 and complete the Final Actions.

Perform GP 9 to reload system software.

22-371-00, 22-372-00 Fax Application Registration Error

22-371-00 Fax Application Registration Error. Status code 22-566 is raised with this fault code

22-372-00 Fax Application Un-Registration Error. Status code 22-567 is raised with this fault code

Procedure

WARNING

Ensure that the electricity to the machine is switched off while performing tasks that do not need electricity. Disconnect the power cord. Electricity can cause death or injury. Moving parts can cause injury.

Cycle system power. **The error persists.**

Y **N**
| Go to SCP 6 and complete the Final Actions.

Reseat USB connections on the Fax and ESS Boards. **The error persists.**

Y **N**
| Go to SCP 6 and complete the Final Actions.

Perform GP 9 to reload system software.

22-407-00 to 22-421-00 Embedded Fax Faults

22-407-00 Install Embedded Fax Fault

22-417-00 Removal Embedded Fax Fault

22-419-00 Enable Embedded Fax Fault

22-421-00 Disable Embedded Fax Fault

Procedure

WARNING

Ensure that the electricity to the machine is switched off while performing tasks that do not need electricity. Disconnect the power cord. Electricity can cause death or injury. Moving parts can cause injury.

Cycle system power. **The error persists.**

Y N
| Go to SCP 6 and complete the Final Actions.

Reseat USB connections on the Fax and ESS Boards. **The error persists.**

Y N
| Go to SCP 6 and complete the Final Actions.

Perform GP 9 to reload system software.

22-701-04 Module Completion Fault

22-701-04 Module completion fault

Procedure

WARNING

Ensure that the electricity to the machine is switched off while performing tasks that do not need electricity. Disconnect the power cord. Electricity can cause death or injury. Moving parts can cause injury.

Cycle system power. **The error persists.**

Y N
| Go to SCP 6 and complete the Final Actions.

Reseat USB connections on the Fax and ESS Boards. **The error persists.**

Y N
| Go to SCP 6 and complete the Final Actions.

Perform GP 9 to reload system software.

22-720-00, 22-721-00 Service Registry Errors

22-720-00 Service Registry Bad data / Corrupted

22-721-00 Triple A gets no response from SRS

NOTE: Status code 16-503 is raised with these fault codes.

Procedure

WARNING

Ensure that the electricity to the machine is switched off while performing tasks that do not need electricity. Disconnect the power cord. Electricity can cause death or injury. Moving parts can cause injury.

Cycle system power. **The error persists.**

Y N
| Go to SCP 6 and complete the Final Actions.

Perform GP 9 to reload system software.

22-750-04 to 22-755-17 Configuration Mismatch RAP

22-750-04 Output Device Configuration Mismatch

22-750-17 Accessory Card Configuration Mismatch

22-751-04 Paper Tray Configuration Mismatch

22-754-17 UI Config change fault

22-755-17 RDT Configuration Mismatch

Initial Actions

Check option installation. Reseat all connections between the option and printer.

Procedure

WARNING

Ensure that the electricity to the machine is switched off while performing tasks that do not need electricity. Disconnect the power cord. Electricity can cause death or injury. Moving parts can cause injury.

Cycle system power. **The error persists.**

Y N
| Go to SCP 6 and complete the Final Actions.

Perform GP 9 to reload system software.

41-340-00 to 41-414-00 IOT NVM Error

41-340-00 IOT NVM-Verify Data Read error

41-342-00 F/W Exception Handling Error

41-400-00 IOT NVM-Read NVM failure version

41-402-00 IOT NVM-Read the data write copy failed area at three locations

41-404-00 IOT NVM-Ack-time error 1byte Read

41-406-00 IOT NVM-Ack-time error Continuous Read

41-408-00 IOT NVM-Write on the device can not start Busy

41-410-00 IOT NVM-Can not Write (Verify error)

41-412-00 IOT NVM-Write process is completed without

41-414-00 IOT NVM-Write retry processing over

NOTE: Status codes 03-561 and 04-563 are raised with this fault code.

Procedure

WARNING

Ensure that the electricity to the machine is switched off while performing tasks that do not need electricity. Disconnect the power cord. Electricity can cause death or injury. Moving parts can cause injury.

CAUTION

Do not replace the MCU and ESS Boards at the same time. Replace or check the ESS Board first, then cycle system power before replacing the MCU Board.

Cycle system power. **The error persists.**

Y N
| Go to SCP 6 and complete the Final Actions.

Check the wiring and connections between the MCU and ESS Boards. **The error persists.**

Y N
| Go to SCP 6 and complete the Final Actions.

Install new components as necessary:

- MCU Board, REP 18.2.2
- ESS Board, REP 18.1.98

41-388-00 Marking Logic Fail

41-388-00 Marking Logic Fail

NOTE: Status codes 03-561 and 04-561 are raised with this fault code.

Procedure

WARNING

Ensure that the electricity to the machine is switched off while performing tasks that do not need electricity. Disconnect the power cord. Electricity can cause death or injury. Moving parts can cause injury.

CAUTION

Do not replace the MCU and ESS Boards at the same time. Replace or check the ESS Board first, then cycle system power before replacing the MCU Board.

Cycle system power. **The error persists.**

Y N
| Go to SCP 6 and complete the Final Actions.

Check the wiring and connections between the MCU and ESS Boards. **The error persists.**

Y N
| Go to SCP 6 and complete the Final Actions.

Perform a Forced AltBoot GP 9 to reload system software. **The error persists.**

Y N
| Go to SCP 6 and complete the Final Actions.

Install new components as necessary:

- MCU Board, REP 18.2.2
- ESS Board, REP 18.1.98

42-313-00 Side Cooling Fan Failure

42-313-00 Cooling Fan Fail

NOTE: Status codes 03-561 and 04-563 are raised with this fault code.

Initial Actions

- Check for accumulations of dust, debris or other obstructions preventing Fan rotation.
- Check the Fan harness for damage.

Procedure

WARNING

Ensure that the electricity to the machine is switched off while performing tasks that do not need electricity. Disconnect the power cord. Electricity can cause death or injury. Moving parts can cause injury.

Use dC330 code 42-003 to test the LVPS Fan. **The Fan rotates.**

Y N
| Check the Fan harness and connections between the Fan and LVPS. **The wiring is good.**
Y N
| Secure the connections or repair the Fan harness as necessary.
|
| Install new components as necessary:
| • LVPS Fan, REP 4.1.1
| • LVPS, REP 18.1.12

Go to SCP 6 and complete the Final Actions.

42-330-00 Fuser Exhaust Fan Fail

42-330-00 Fuser Exhaust Fan Fail

NOTE: Status codes 03-561 and 04-563 are raised with this fault code.

Initial Actions

- Check for accumulations of dust, debris or other obstructions preventing Fan rotation.
- Check the Fan harness for damage.

Procedure

WARNING

Ensure that the electricity to the machine is switched off while performing tasks that do not need electricity. Disconnect the power cord. Electricity can cause death or injury. Moving parts can cause injury.

Use dC330 code 42-001 to test the Rear Fan. **The Fan rotates.**

Y N
| Check the Fan harness and connections between the Fan and LVPS. **The wiring is good.**
Y N
| Secure the connections or repair the Fan harness as necessary.
|
| Install new components as necessary:
| • Rear Fan, REP 19.3.9
| • LVPS, REP 18.1.12

Go to SCP 6 and complete the Final Actions.

45-301-00 to 45-305-00 IOT I/F Error

41-301-00 I/F Ack Unreceived High

41-302-00 I/F Ack Unreceived Low

41-303-00 I/F Received Buffer Overflow

41-304-00 I/F Send Buffer High Overflow

41-305-00 I/F Send Buffer Low Overflow

NOTE: Status codes 03-561 and 04-566 are raised with this fault code.

Procedure

WARNING

Ensure that the electricity to the machine is switched off while performing tasks that do not need electricity. Disconnect the power cord. Electricity can cause death or injury. Moving parts can cause injury.

CAUTION

Do not replace the MCU and ESS Boards at the same time. Replace or check the ESS Board first, then cycle system power before replacing the MCU Board. Simultaneous replacement of IP and MCU Boards will make the printer inoperable.

Cycle system power. **The error persists.**

Y N
| Go to SCP 6 and complete the Final Actions.

Check the wiring and connections between the MCU and ESS Boards. **The wiring is good.**

Y N
| Re-seat loose connectors or install new components as necessary:

- MCU Board, REP 18.2.2
- ESS Board, REP 18.1.98

Go to SCP 6 and complete the Final Actions.

61-020-00 to 61-340-00 ROS Error

61-020-00 ROS Rotation fail

61-327-00 ROS Warm up fail

61-340-00 ROS LD fail

NOTE: Status codes 03-561 and 06-515 are raised with this fault code.

Procedure

WARNING

Ensure that the electricity to the machine is switched off while performing tasks that do not need electricity. Disconnect the power cord. Electricity can cause death or injury. Moving parts can cause injury.

Cycle system power. **The error persists.**

Y N
| Go to SCP 6 and complete the Final Actions.

Use dC330 code 61-001 to test the Laser Unit motor. **The Laser Unit motor rotates.**

Y N
| Replace the Laser Unit, REP 2.1.1

Replace the ESS Board, REP 18.1.98. **The error persists.**

Y N
| Perform SCP 6 Final Actions.

Replace the MCU Board, REP 18.2.2.

62-311-00 to 62-389-00 IIT Scan Error

62-311-00 IISS LOGIC Fail. Status code 03-557 is raised with this fault code.

62-317-00 IIT Video Over-run

62-318-00 IIT Scanning Timing error

62-319-00 PLL Lock Time Out error

62-321-00 Scan failure

62-322-00 S/W Parameter error

62-360-00 CRG Position Fail

62-345-00 IISS EEPROM Fail

62-362-00 X Hard Fail

62-380-00 AGC Fail

62-386-00 AOC Fail

62-389-00 CRG Over Run Fail

NOTE: Status code 14-517 is raised with these fault codes.

Procedure

WARNING

Ensure that the electricity to the machine is switched off while performing tasks that do not need electricity. Disconnect the power cord. Electricity can cause death or injury. Moving parts can cause injury.

Cycle system power. **The error persists.**

Y N
| Go to SCP 6 and complete the Final Actions.

Check connections and wiring between the IIT Assembly (Scanner) and ESS Board. **The wiring is good.**

Y N
| Repair or reseal wiring as needed.

Install new components as necessary:

- IIT Control Board, REP 18.1.4
- IIT Assembly, REP 21.1.14
- ESS Board, REP 18.1.98

62-316-00 DADF Motor Fail

62-316-00 DADF Motor Fail

NOTE: Status code 14-517 is raised with this fault code.

Procedure

WARNING

Ensure that the electricity to the machine is switched off while performing tasks that do not need electricity. Disconnect the power cord. Electricity can cause death or injury. Moving parts can cause injury.

Cycle system power. **The error persists.**

Y N
| Go to SCP 6 and complete the Final Actions.

Check connections and wiring between the DADF Assembly and ESS Board. **The wiring is good.**

Y N
| Repair or reseal wiring as needed.

Install new components as necessary:

- DADF Assembly, REP 21.1.1
- IIT Control Board, REP 18.1.4
- ESS Board REP 18.1.98

62-790-00 PreIPS XFail

62-790-00 PreIPS XFail. Bank note detected.

Procedure

WARNING

Ensure that the electricity to the machine is switched off while performing tasks that do not need electricity. Disconnect the power cord. Electricity can cause death or injury. Moving parts can cause injury.

Cycle system power. **The error persists.**

Y N
| Go to SCP 6 and complete the Final Actions.

Check connections and wiring between the IIT Assembly and ESS Board. **The wiring is good.**

Y N
| Repair or reseal wiring as needed.

Install new components as necessary:

- IIT Assembly, REP 21.1.14
- IIT Control Board, REP 18.1.4
- ESS Board, REP 18.1.98

70-099-00 I/F IOTFED Communication

70-099-00 I/F IOTFED Communication

NOTE: Status codes 03-561 and 92-530 are raised with this fault code.

Initial Actions

- Lock the Optional Feeder to the printer.
- Reseat the printer on the Optional Feeder.
- Check for damage to the option connections.

Procedure

WARNING

Switch off the electricity to the machine. Disconnect the power cord from the customer supply while performing tasks that do not need electricity. Electricity can cause death or injury. Moving parts can cause injury.

WARNING

Use safe handling procedures when removing the module. Refer to GP 20. The module is heavy.

Cycle system power. **The error persists.**

Y N
| Go to SCP 6 and complete the Final Actions.

Remove the printer from the Optional Feeder. Check feeder option connector continuity. **The harnesses are undamaged.**

Y N
| Repair the damaged option harness.

Install new components as necessary:

- Feeder Board, REP 11.1.5
- MCU Board, REP 18.2.2

71-101-00 Tray1 Misfeed Jam

71-101-00 Tray1 Misfeed Jam

NOTE: Status code 07-501 is raised with this fault code.

Initial Actions

- Check media condition.
- Check for obstructions in the media path.
- Check Tray 1 media guides and lift operation.
- Check Feed Roller condition.
- Check actuator condition.

Procedure

WARNING

Switch off the electricity to the machine. Disconnect the power cord from the customer supply while performing tasks that do not need electricity. Electricity can cause death or injury. Moving parts can cause injury.

Check the Nudger, Feed, and Retard Rollers for excessive wear or contamination. **The rollers are undamaged and clean.**

Y N
| Clean or replace the rollers.

Use dC330 code 071-102 to test the Registration Sensor. **The sensor signal changes.**

Y N
| Check the connection between the HVPS and MCU Board. **The connection is secure.**
Y N
| Secure the connection.

Replace the HVPS, REP 18.2.5.

Use dC330 code 071-005 to test the Feed Clutch. **The clutch activates.**

Y N
| Replace the Feed Clutch, REP 15.2.16.

Use dC330 code 071-001 to test the Main Drive Assembly. **The motor rotates.**

Y N
| Replace the Main Drive Assembly, REP 3.1.1.

Install new components as necessary:

- Feed Rollers, REP 9.2.98
- MCU Board, REP 18.2.2

71-215-00 Tray 1 Feeder Composition Error

71-215-00 Tray 1 Feeder Composition Error

NOTE: Status codes 03-561 and 72-215 are raised with this fault code.

Procedure

WARNING

Switch off the electricity to the machine. Disconnect the power cord from the customer supply while performing tasks that do not need electricity. Electricity can cause death or injury. Moving parts can cause injury.

WARNING

Use safe handling procedures when removing the module. Refer to GP 20. The module is heavy.

Verify product and option compatibility, **The Tray is supported.**

Y N
| Install the correct Tray.

Perform GP 9 to reload system software. Reinstall the Tray and test. **The error persists.**

Y N
| Perform SCP 6 Final Actions.

Perform a Forced AltBoot GP 9 to reload system software.

72-098-00 to 74-098-00 Option Feeder Mode

72-098-00 Option Feeder2 Mode

73-098-00 Option Feeder3 Mode

74-098-00 Option Feeder4 Mode

NOTE: Status codes 03-561 and 77-098 are raised with this fault code.

Procedure

WARNING

Switch off the electricity to the machine. Disconnect the power cord from the customer supply while performing tasks that do not need electricity. Electricity can cause death or injury. Moving parts can cause injury.

WARNING

Use safe handling procedures when removing the module. Refer to GP 20. The module is heavy.

Cycle system power. **The error persists.**

Y N
| Go to SCP 6 and complete the Final Actions.

Remove the Optional Feeder, then obtain the appropriate system software set and perform GP 9 to reload system software. Reinstall the Optional Feeder and test. **The error persists.**

Y N
| Perform SCP 6 Final Actions.

Replace the Feeder Board, REP 11.1.5.

72-101-00 Tray 2 Misfeed Jam

72-101-00 Tray2 Misfeed Jam

NOTE: Status code 07-502 is raised with this fault code.

Initial Actions

- Check media condition.
- Check for obstructions in the media path.
- Check Tray 2 media guides and lift operation.
- Check Feed and Take Away Roller condition.
- Check actuator condition.

Procedure

WARNING

Switch off the electricity to the machine. Disconnect the power cord from the customer supply while performing tasks that do not need electricity. Electricity can cause death or injury. Moving parts can cause injury.

Check the Nudger, Feed, and Retard Rollers for excessive wear or contamination. The rollers are undamaged and clean.

Y N
Clean or replace the rollers.

Use dC330 code 071-119 to test the Tray 2 Path Sensor. The sensor signal changes.

Y N
Replace the Path Sensor, REP 11.4.4.

Use dC330 code 071-018 to test the Tray 2 Feed Solenoid. The clutch activates.

Y N
Replace the Feed Clutch, REP 11.1.8.

Use dC330 code 071-021 to test the Tray 2 Registration. The clutch activates.

Y N
Replace the Registration Clutch, REP 11.2.20.

Use dC330 code 071-009 to test the Tray 2 Feed Motor. The motor rotates.

Y N
Replace the Feed Motor, REP 11.1.5.

Install new components as necessary:

- Option Feeder Feed Assembly, REP 11.1.20
- MCU Board, REP 18.2.2

72-102-00 Feeder Path 2 Sensor On Jam (RC2)

72-102-00 Feeder Path 2 Sensor On Jam (RC2)

NOTE: Status code 07-508 is raised with this fault code.

Initial Actions

- Check for obstructions in the media path.
- Check Optional Feeder Path Sensor actuator condition.

Procedure

WARNING

Switch off the electricity to the machine. Disconnect the power cord from the customer supply while performing tasks that do not need electricity. Electricity can cause death or injury. Moving parts can cause injury.

Check the Nudger, Feed, and Separator Rollers for excessive wear or contamination. The rollers are undamaged and clean.

Y N
Clean or replace the rollers.

Use dC330 code 071-102 to test the Registration Sensor. The sensor signal changes.

Y N
Check the connection between the HVPS and MCU Board. The connection is secure.

Y N
Secure the connection.

Replace the HVPS, REP 18.2.5.

Use dC330 code 071-119 to test the Tray 2 Path Sensor. The sensor signal changes.

Y N
Replace the Path Sensor, REP 11.4.4.

Use dC330 code 071-018 to test the Tray 2 Feed Solenoid. The clutch activates.

Y N
Replace the Feed Clutch, REP 11.1.8.

Use dC330 code 071-021 to test the Tray 2 Registration. The clutch activates.

Y N
Replace the Registration Clutch, REP 11.2.20.

Use dC330 code 071-009 to test the Tray 2 Feed Motor. The motor rotates.

Y N
Replace the Feed Motor, REP 11.1.5.

Install new components as necessary:

- Option Feeder Feed Assembly, REP 11.1.20
- MCU Board, REP 18.2.2

72-215-00 Tray 2 Feeder Composition Error

72-215-00 Tray 2 Feeder Composition Error

NOTE: Status codes 03-561 and 77-216 are raised with this fault code.

Initial Actions

- Check Optional Feeder part number.
- Check Optional Feeder installation.

Procedure

WARNING

Switch off the electricity to the machine. Disconnect the power cord from the customer supply while performing tasks that do not need electricity. Electricity can cause death or injury. Moving parts can cause injury.

Cycle system power. **The error persists.**

Y	N
	Perform SCP 6 Final Actions.

Install new components as necessary:

- Option Feeder Board, REP 11.1.5
- Optional Feeder Assembly, REP 11.1.99
- MCU Board, REP 18.2.2

72-216-00 Option Feeder Motor2 Error

72-216-00 Option Feeder Motor2

NOTE: Status codes 03-561 and 77-216 are raised with this fault code.

Initial Actions

- Check for obstructions in the media path.
- Check Optional Feeder installation.

Procedure

WARNING

Switch off the electricity to the machine. Disconnect the power cord from the customer supply while performing tasks that do not need electricity. Electricity can cause death or injury. Moving parts can cause injury.

Use dC330 code 071-009 to test the Tray 2 Feed Motor. **The motor rotates.**

Y	N
	Replace the Feed Motor, REP 11.1.7

Install new components as necessary:

- Option Feeder Board, REP 11.1.5
- MCU Board, REP 18.2.2

73-101-00 Tray3 Misfeed Jam

73-101-00 Tray3 Misfeed Jam

NOTE: Status code 07-503 is raised with this fault code.

Initial Actions

- Check media condition.
- Check for obstructions in the media path.
- Check Tray 3 media guides and lift operation.
- Check Feed and Take Away Roller condition.
- Check actuator condition.

Procedure

WARNING

Switch off the electricity to the machine. Disconnect the power cord from the customer supply while performing tasks that do not need electricity. Electricity can cause death or injury. Moving parts can cause injury.

Check the Nudger, Feed, and Retard Rollers for excessive wear or contamination. The rollers are undamaged and clean.

Y N
Clean or replace the rollers.

Use dC330 code 071-120 to test the Tray 3 Path Sensor. The sensor signal changes.

Y N
Replace the Path Sensor, REP 11.4.4.

Use dC330 code 071-019 to test the Tray 3 Feed Solenoid. The clutch activates.

Y N
Replace the Feed Clutch, REP 11.1.8.

Use dC330 code 071-022 to test the Tray 3 Registration. The clutch activates.

Y N
Replace the Registration Clutch, REP 11.2.20.

Use dC330 code 071-009 to test the Tray 2 Feed Motor. The motor rotates.

Y N
Replace the Feed Motor, REP 11.1.5.

Install new components as necessary:

- Option Feeder Feed Assembly, REP 11.1.20
- MCU Board, REP 18.2.2

73-102-00 Path 3 Sensor On Jam (RC3)

73-102-00 Path 3 Sensor On Jam (RC3)

NOTE: Status code 07-507 is raised with this fault code.

Initial Actions

1. Check for obstructions in the media path.
2. Check Optional Feeder Path Sensor actuator condition.

Procedure

WARNING

Switch off the electricity to the machine. Disconnect the power cord from the customer supply while performing tasks that do not need electricity. Electricity can cause death or injury. Moving parts can cause injury.

Check the Nudger, Feed, and Separator Rollers for excessive wear or contamination. The rollers are undamaged and clean.

Y N
Clean or replace the rollers.

Use dC330 code 071-102 to test the Registration Sensor. The sensor signal changes.

Y N
Check the connection between the HVPS and MCU Board. The connection is secure.

Y N
Secure the connection.

Replace the HVPS, REP 18.2.5.

Use dC330 code 071-120 to test the Tray 3 Path Sensor. The sensor signal changes.

Y N
Replace the Path Sensor, REP 11.4.4.

Use dC330 code 071-019 to test the Tray 3 Feed Solenoid. The clutch activates.

Y N
Replace the Feed Clutch, REP 11.1.8.

Use dC330 code 071-022 to test the Tray 2 Registration. The clutch activates.

Y N
Replace the Registration Clutch, REP 11.2.20.

Use dC330 code 071-012 to test the Tray 3 Feed Motor. The motor rotates.

Y N
Replace the Feed Motor, REP 11.1.5.

Install new components as necessary:

- Option Feeder Feed Assembly, REP 11.1.20
- MCU Board, REP 18.2.2

73-215-00 Tray 3 Feeder Composition Error

73-215-00 Tray 3 Feeder Composition Error

NOTE: Status codes 03-561 and 77-216 are raised with this fault code.

Initial Actions

- Check Optional Feeder part number.
- Check Optional Feeder installation.

Procedure

WARNING

Switch off the electricity to the machine. Disconnect the power cord from the customer supply while performing tasks that do not need electricity. Electricity can cause death or injury. Moving parts can cause injury.

Cycle system power. **The error persists.**

Y	N
	Perform SCP 6 Final Actions.

Install new components as necessary:

- Option Feeder Board, REP 11.1.5
- Optional Feeder Assembly, REP 11.1.99
- MCU Board, REP 18.2.2

73-216-00 Option Feeder Motor3 Error

73-216-00 Option Feeder Motor3

NOTE: Status codes 03-561 and 77-216 are raised with this fault code.

Initial Actions

- Check for obstructions in the media path.
- Check Optional Feeder installation.

Procedure

WARNING

Switch off the electricity to the machine. Disconnect the power cord from the customer supply while performing tasks that do not need electricity. Electricity can cause death or injury. Moving parts can cause injury.

Use dC330 code 071-012 to test the Tray 3 Feed Motor. **The motor rotates.**

Y	N
	Replace the Feed Motor, REP 11.1.7.

Install new components as necessary:

- Option Feeder Board, REP 11.1.5
- MCU Board, REP 18.2.2

74-101-00 Tray 4 Misfeed Jam

74-101-00 Tray4 Misfeed Jam

NOTE: Status code 07-504 is raised with this fault code.

Initial Actions

- Check media condition.
- Check for obstructions in the media path.
- Check Tray 4 media guides and lift operation.
- Check Feed and Take Away Roller condition.
- Check actuator condition.

Procedure

WARNING

Switch off the electricity to the machine. Disconnect the power cord from the customer supply while performing tasks that do not need electricity. Electricity can cause death or injury. Moving parts can cause injury.

Check the Nudger, Feed, and Retard Rollers for excessive wear or contamination. The rollers are undamaged and clean.

Y N
Clean or replace the rollers.

Use dC330 code 071-120 to test the Tray 3 Path Sensor. The sensor signal changes.

Y N
Replace the Path Sensor, REP 11.4.4.

Use dC330 code 071-019 to test the Tray 3 Feed Solenoid. The clutch activates.

Y N
Replace the Feed Clutch, REP 11.1.8.

Use dC330 code 071-022 to test the Tray 3 Registration. The clutch activates.

Y N
Replace the Registration Clutch, REP 11.2.20.

Use dC330 code 071-009 to test the Tray 2 Feed Motor. The motor rotates.

Y N
Replace the Feed Motor, REP 11.1.5.

Install new components as necessary:

- Option Feeder Feed Assembly, REP 11.1.20
- MCU Board, REP 18.2.2

74-215-00 Tray 4 Feeder Composition Error

74-215-00 Tray 4 Feeder Composition Error

NOTE: Status codes 03-561 and 77-216 are raised with this fault code.

Initial Actions

1. Check Optional Feeder part number.
2. Check Optional Feeder installation.

Procedure

WARNING

Switch off the electricity to the machine. Disconnect the power cord from the customer supply while performing tasks that do not need electricity. Electricity can cause death or injury. Moving parts can cause injury.

Cycle system power. The error persists.

Y N
Perform SCP 6 Final Actions.

Install new components as necessary:

1. Option Feeder Board, REP 11.1.5
2. Optional Feeder Assembly, REP 11.1.99
3. MCU Board, REP 18.2.2

74-216-00 Option Feeder Motor4 Error

74-216-00 Option Feeder Motor4

NOTE: Status codes 03-561 and 77-216 are raised with this fault code.

Initial Actions

1. Check for obstructions in the media path.
2. Check Optional Feeder installation.

Procedure

WARNING

Switch off the electricity to the machine. Disconnect the power cord from the customer supply while performing tasks that do not need electricity. Electricity can cause death or injury. Moving parts can cause injury.

Use dC330 code 071-015 to test the Tray 4 Feed Motor. **The motor rotates.**

Y N
|
Replace the Feed Motor, REP 11.1.7.

Install new components as necessary:

1. Option Feeder Board
2. MCU Board, REP 18.2.2

75-101-00 Bypass Misfeed Jam

75-101-00 Bypass Misfeed Jam

NOTE: Status code 07-505 is raised with this fault code.

Initial Actions

1. Check media condition.
2. Check for obstructions in the media path.

Procedure

WARNING

Switch off the electricity to the machine. Disconnect the power cord from the customer supply while performing tasks that do not need electricity. Electricity can cause death or injury. Moving parts can cause injury.

Check the Nudger, Feed, and Separator Rollers for excessive wear or contamination. **The rollers are undamaged and clean.**

Y N
|
Clean or replace the rollers.

Use dC330 code 071-102 to test the Registration Sensor. **The sensor signal changes.**

Y N
|
Replace the Registration Sensor.

Use dC330 code 071-004 to test the Feed Solenoid. **The solenoid activates.**

Y N
|
Replace the MSI Feed Solenoid.

Use dC330 code 071-001 to test the Main Drive Assembly. **The motor rotates.**

Y N
|
Replace the Main Drive Assembly, REP 3.1.1.

Install new components as necessary:

1. MSI Pick-up Assembly, REP 13.1.15
2. MCU Board, REP 18.2.2

77-101-00 Regi Off Jam

77-101-00 Regi Off Jam

NOTE: Status code 07-522 is raised with this fault code.

Initial Actions

1. Check media condition.
2. Check for obstructions in the media path.

Procedure

WARNING

Switch off the electricity to the machine. Disconnect the power cord from the customer supply while performing tasks that do not need electricity. Electricity can cause death or injury. Moving parts can cause injury.

Check the Nudger, Feed, and Separator Rollers for excessive wear or contamination. **The rollers are undamaged and clean.**

Y N
Clean or replace the rollers.

Use dC330 code 071-102 to test the Registration Sensor. **The sensor signal changes.**

Y N
Replace the Registration Sensor.

Use dC330 code 071-006 to test the Registration Clutch. **The clutch activates.**

Y N
Replace the Registration Clutch.

Use dC330 code 071-001 to test the Main Drive Assembly. **The motor rotates.**

Y N
Replace the Main Drive Assembly, REP 3.1.1.

Install new components as necessary:

1. Transport Assembly, REP 15.1.6
2. MCU Board, REP 18.2.2

77-102-00 Psync On Jam

77-102-00 Psync On Jam

NOTE: Status code 07-5?? is raised with this fault code.

Initial Actions

1. Check media condition.
2. Check for obstructions in the media path.

Procedure

WARNING

Switch off the electricity to the machine. Disconnect the power cord from the customer supply while performing tasks that do not need electricity. Electricity can cause death or injury. Moving parts can cause injury.

Check the Nudger, Feed, and Separator Rollers for excessive wear or contamination. **The rollers are undamaged and clean.**

Y N
Clean or replace the rollers.

Use dC330 code 071-102 to test the Registration Sensor. **The sensor signal changes.**

Y N
Replace the Registration Sensor.

Use dC330 code 071-006 to test the Registration Clutch. **The clutch activates.**

Y N
Replace the Registration Clutch.

Use dC330 code 071-001 to test the Main Drive Assembly. **The motor rotates.**

Y N
Replace the Main Drive Assembly, REP 3.1.1.

Cycle system power. **The error persists.**

Y N
Perform SCP 6 Final Actions.

Perform GP 9 to reload system software. **The error persists.**

Y N
Perform SCP 6 Final Actions.

Install new components as necessary:

1. Transport Assembly, REP 15.1.6
2. MCU Board, REP 18.2.2

77-103-00, 77-104-00, 77-106-00 Exit On/Off Jam

77-103-00 Exit Off Jam

77-104-00 Exit Off Early Jam

77-106-00 Exit On Jam

NOTE: Status code 07-5?? is raised with this fault code.

Initial Actions

1. Check Exit Sensor actuator operation.
2. Check for obstructions in the media path.

Procedure

WARNING

Switch off the electricity to the machine. Disconnect the power cord from the customer supply while performing tasks that do not need electricity. Electricity can cause death or injury. Moving parts can cause injury.

WARNING

Do not touch the Fuser while it is hot.

Check the Nudger, Feed, and Separator Rollers for excessive wear or contamination. The rollers are undamaged and clean.

Y N
Clean or replace the rollers.

Use dC330 code 071-103 to test the Exit Sensor. The sensor signal changes.

Y N
Replace the Exit Sensor.

Use dC330 code 071-102 to test the Registration Sensor. The sensor signal changes.

Y N
Replace the Registration Sensor.

Use dC330 code 071-007 to test the Exit Clutch. The clutch activates.

Y N
Replace the Exit Clutch.

Use dC330 code 071-006 to test the Registration Clutch. The clutch activates.

Y N
Replace the Registration Clutch.

Use dC330 code 071-001 to test the Main Drive Assembly. The motor rotates.

Y N
Replace the Main Drive Assembly, REP 3.1.1.

Install new components as necessary:

1. Exit Chute Assembly, REP 17.1.99
2. MCU Board, REP 18.2.2

77-110-00 Feeder Regi Sensor On Jam

77-110-00 Feeder Regi sensor On Jam

NOTE: Status code 07-520 is raised with this fault code.

Initial Actions

1. Check media condition.
2. Check for obstructions in the media path.

Procedure

WARNING

Switch off the electricity to the machine. Disconnect the power cord from the customer supply while performing tasks that do not need electricity. Electricity can cause death or injury. Moving parts can cause injury.

Check the Nudger, Feed, and Separator Rollers for excessive wear or contamination. The rollers are undamaged and clean.

Y N
Clean or replace the rollers.

Use dC330 code 071-102 to test the Registration Sensor. The sensor signal changes.

Y N
Replace the Registration Sensor.

Use dC330 code 071-006 to test the Registration Clutch. The clutch activates.

Y N
Replace the Registration Clutch.

Use dC330 code 071-001 to test the Main Drive Assembly. The motor rotates.

Y N
Replace the Main Drive Assembly, REP 3.1.1.

Install new components as necessary:

1. Transport Assembly, REP 15.1.6
2. MCU Board, REP 18.2.2

77-123-00 Duplex Regi On Jam

77-110-00 Duplex Regi On Jam (also see Eureka Tip #1367425)

NOTE: Status code 07-511 is raised with this fault code.

Initial Actions

1. Check Rear Cover latch and fitment.
2. Check media condition.
3. Check for obstructions in the media path.

Procedure

WARNING

Switch off the electricity to the machine. Disconnect the power cord from the customer supply while performing tasks that do not need electricity. Electricity can cause death or injury. Moving parts can cause injury.

WARNING

Do not touch the Fuser while it is hot.

Check the Duplex, Exit, and Pinch Rollers for excessive wear or contamination. The rollers are undamaged and clean.

Y N
|
Clean or replace the rollers.

Use dC330 code 071-006 to test the Registration Clutch. The clutch activates.

Y N
|
Replace the Registration Clutch. REP 15.2.4.

Use dC330 code 071-008 to test the Exit Invert Clutch. The clutch activates.

Y N
|
Replace the Exit Invert Drive Assembly, REP 3.1.3.

Use dC330 code 071-001 to test the Main Drive Assembly. The motor rotates.

Y N
|
Replace the Main Drive Assembly, REP 3.1.1.

Install new components as necessary:

1. Duplex Chute Assembly, REP 14.1.12
2. Exit Drive Assembly, REP 3.1.2
3. Transport Assembly, REP 15.1.6
4. MCU Board, REP 18.2.2
5. Rear Door Assembly PL 19.3

77-300-00 Front Door Interlock Open

77-300-00 Front Door Interlock Open

NOTE: Status code 01-510 is raised with this fault code.

Initial Actions

1. Check Front Cover latch and fitment.
2. Check front interlock actuator
3. Check Front Interlock Switch position and condition.

Procedure

WARNING

Switch off the electricity to the machine. Disconnect the power cord from the customer supply while performing tasks that do not need electricity. Electricity can cause death or injury. Moving parts can cause injury.

Use dC330 code 041-300 to test the Front Interlock Switch. The switch signal changes.

Y N
|
Repair the Front Interlock Switch.

Install new components as necessary:

1. Front Cover Assembly, REP 19.1.96
2. MCU Board, REP 18.2.2

77-301-00 Rear Door Interlock Open

77-301-00 Rear Door Interlock Open

NOTE: Status code 01-516 is raised with this fault code.

Initial Actions

1. Check Rear Cover latch and fitment.
2. Check rear interlock actuator
3. Check Rear Interlock Switch position and condition.

Procedure

WARNING

Switch off the electricity to the machine. Disconnect the power cord from the customer supply while performing tasks that do not need electricity. Electricity can cause death or injury. Moving parts can cause injury.

WARNING

Do not touch the Fuser while it is hot.

Use dC330 code 041-301 to test the Rear interlock Switch **The switch signal changes.**

Y N
| Replace the Rear Interlock Switch, REP 15.1.97.

Install new components as necessary:

1. Rear Door Assembly, REP 19.3.99
2. LVPS, REP 18.1.12
3. MCU Board, REP 18.2.2

77-900-00 IOT Static Jam

77-900-00 IOT Static Jam

NOTE: Status code 07-510 is raised with this fault code.

Initial Actions

1. Clear any media from the media path.
2. Check for obstructions at or near the Registration Sensor Actuator.
3. Cycle system power.

Procedure

WARNING

Switch off the electricity to the machine. Disconnect the power cord from the customer supply while performing tasks that do not need electricity. Electricity can cause death or injury. Moving parts can cause injury.

Use dC330 code 071-102 to test the Registration Sensor. **The sensor signal changes.**

Y N
| Replace the Registration Sensor.

Install new components as necessary:

1. Transport Assembly, REP 15.1.6
2. MCU Board, REP 18.2.2

77-901-00 Feeder Static Jam

77-901-00 Feeder Static Jam. Message, "Remove Paper behind Tray 1".

NOTE: Status code 07-520 is raised with this fault code.

Initial Actions

1. Clear any media from the media path, and behind the Bypass Tray.
2. Check for obstructions at or near the Exit Sensor.
3. Cycle system power.

Procedure

WARNING

Switch off the electricity to the machine. Disconnect the power cord from the customer supply while performing tasks that do not need electricity. Electricity can cause death or injury. Moving parts can cause injury.

WARNING

Do not touch the Fuser while it is hot.

Use the appropriate dC330 code for the Paper Path Sensors

All sensors are LOW in Standby.

- 071-102 Registration Sensor
- 071-103 Exit Sensor
- 071-119 Tray 2 Path Sensor
- 071-120 Tray 3 Path Sensor
- 071-118 Tray 4 Path Sensor

Y N

Repair or replace the problem sensor

Install new components as necessary:

1. Feed Assembly, REP 11.1.20
2. MCU Board, REP 18.2.2

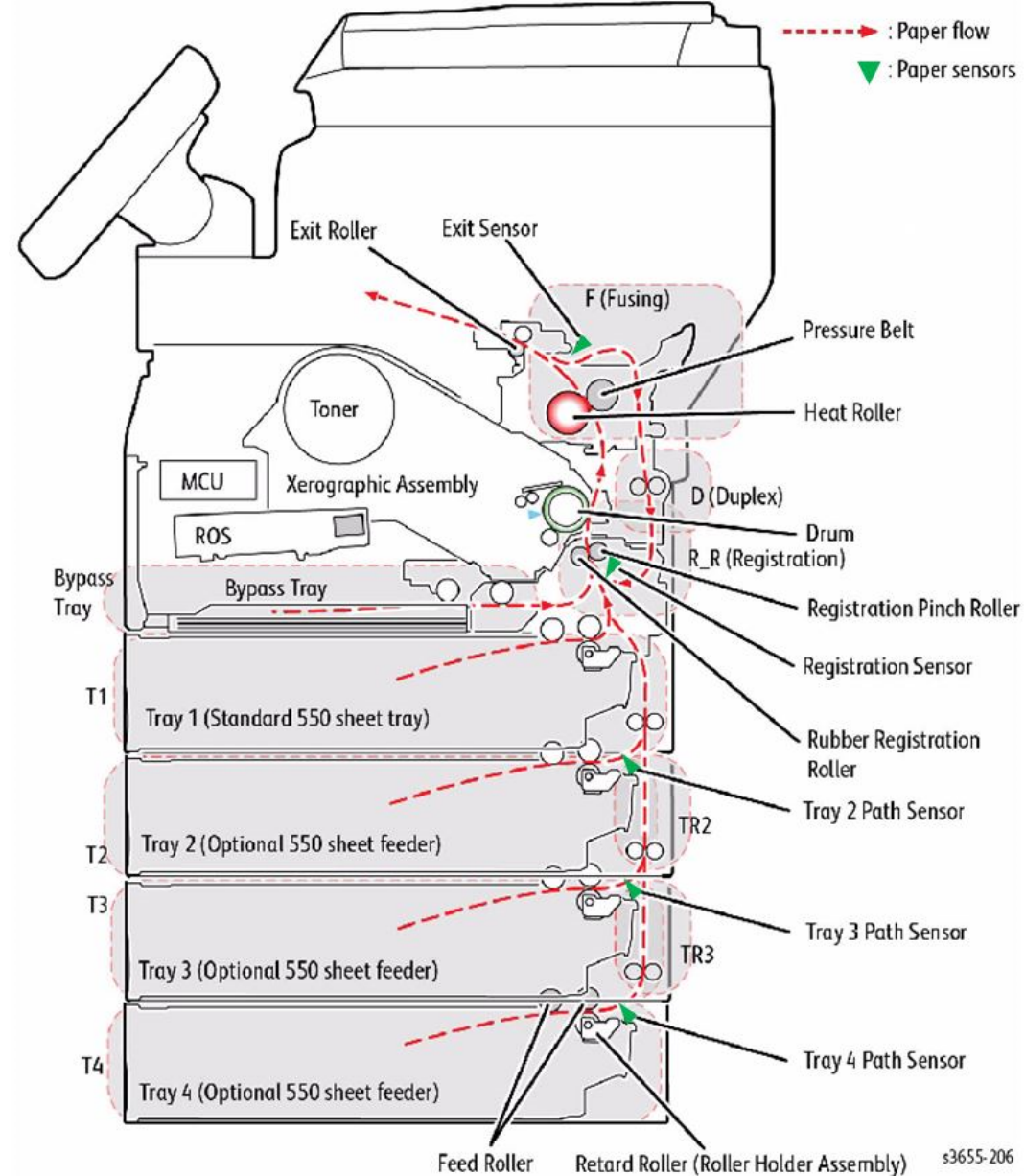

91-401-00, 91-402-00 K Drum Cartridge Life Near End

91-401-00 K Drum Cartridge Life Near End

91-402-00 K Drum Cartridge Life End

NOTE: Status code 09-533 is raised with these fault codes.

Initial Actions

- Reseat the Drum Cartridge.
- Verify Drum Cartridge is genuine Xerox.
- Cycle system power.

Procedure

WARNING

Switch off the electricity to the machine. Disconnect the power cord from the customer supply while performing tasks that do not need electricity. Electricity can cause death or injury. Moving parts can cause injury.

Check Drum Cartridge life count. **The Drum Cartridge is at or near end of life.**

Y	N
	Reseat the Drum Cartridge and cycle system power. The error persists.
	Y N
	Perform SCP 6 Final Actions
	Install new components as necessary:
	• Xerographic Connector, REP 5.1.10
	• MCU Board, REP 18.2.2

Replace the Drum Cartridge, REP 8.1.1 from customer stock.

91-913-00 K Drum Cartridge Dead Stop Error

91-913-00 K Drum Cartridge Dead Stop Error

NOTE: Status code 09-521 is raised with these fault codes.

Initial Actions

- Reseat the Drum Cartridge.
- Verify Drum Cartridge is genuine Xerox.
- Cycle system power.

Procedure

WARNING

Switch off the electricity to the machine. Disconnect the power cord from the customer supply while performing tasks that do not need electricity. Electricity can cause death or injury. Moving parts can cause injury.

Cycle system power. **The error persists.**

Y	N
	Go to SCP 6 and complete the Final Actions.

Check Drum Cartridge life count. **The Drum Cartridge is at or near end of life.**

Y	N
	Reseat the Drum Cartridge and cycle system power. The error persists.
	Y N
	Perform SCP 6 Final Actions
	Install new components as necessary:
	• Toner Cartridge, REP 8.1.2
	• Xerographic Connector, REP 5.1.10
	• MCU Board, REP 18.2.2

Replace the Drum Cartridge, REP 8.1.1 from customer stock.

91-914-00 to 91-936-00 K Drum Cartridge Error

91-914-00 K Drum Cartridge Comm Error

91-915-00 K Drum Cartridge Data Error

91-921-00 K Drum Cartridge Missing. Status code 09-553.

91-936-00 K Drum Cartridge ID Error

NOTE: Status codes 03-561 and 09-548 are raised with these fault codes.

Initial Actions

- Verify Drum Cartridge is genuine Xerox.
- Inspect the Drum Cartridge Xerographic Connector.
- Cycle system power.

Procedure

WARNING

Switch off the electricity to the machine. Disconnect the power cord from the customer supply while performing tasks that do not need electricity. Electricity can cause death or injury. Moving parts can cause injury.

Check Xerographic Connector condition. **The Xerographic Connector is good.**

Y N
| Replace the Xerographic Connector. **The error persists.**
Y N
| Perform SCP 6 Final Actions
Install new components as necessary:

- Xerographic Connector, REP 5.1.10
- MCU Board, REP 18.2.2

Replace the Drum Cartridge, REP 8.1.1 from customer stock.

92-315-00 ATCFail [K]

92-315-00 ATCFail [K]

NOTE: Status codes 03-561 and 04-563 are raised with this fault code. Fault codes are not cleared by power Off/On if the number of of ATC Fail faults reached the threshold value.

Initial Actions

- Verify Drum Cartridge is genuine Xerox.
- Clean the area surrounding the ATC Sensor.
- Inspect the Drum Cartridge Xerographic Connector.
- Cycle system power.

Procedure

WARNING

Switch off the electricity to the machine. Disconnect the power cord from the customer supply while performing tasks that do not need electricity. Electricity can cause death or injury. Moving parts can cause injury.

Check the Drum Cartridge life count. **Drum Cartridge life remains.**

Y N
| Replace the Drum Cartridge, REP 8.1.1 from customer stock.

Check Xerographic Connector condition. **The Xerographic Connector is good.**

Y N
| Replace the Xerographic Connector. **The error persists.**
Y N
| Perform SCP 6 Final Actions
Install new components as necessary:

- Xerographic Connector, REP 5.1.10
- MCU Board, REP 18.2.2

Replace the Drum Cartridge, REP 8.1.1 from customer stock.

92-584-00, 92-586-00 Internal - Over Temp Failure

92-584-00 Internal temperature over temp Broken. Status codes 03-561 and 04-563 are raised with this fault code.

92-586-00 Internal - Over temp failure

Initial Actions

- Verify printer installation complies with environmental specifications.
- Clear vents of any dust accumulation.
- Cycle system power.

Procedure

WARNING

Switch off the electricity to the machine. Disconnect the power cord from the customer supply while performing tasks that do not need electricity. Electricity can cause death or injury. Moving parts can cause injury.

Use dC140 code 091-200 to check environmental sensor operation. **The sensor is good.**

Y N
| Replace the HVPS, REP 18.2.5.

Use dC330 code 042-001 to test the Rear Fan. **The fan rotates.**

Y N
| Replace the Rear Fan, REP 19.3.9.

Use dC330 code 042-003 to test the LVPS Fan **The fan rotates.**

Y N
| Replace the LVPS Fan, REP 4.1.1.

Install new components as necessary:

- HVPS, REP 18.2.5
- LVPS, REP 18.1.12
- MCU Board, REP 18.2.2

92-650-00 K Image Calibration Error 1

92-650-00 K Image Calibration Error 1

NOTE: Status codes 03-561 and 09-548 are raised with this fault code. .

Initial Actions

- Verify Drum Cartridge is genuine Xerox.
- Clean the area surrounding the ATC Sensor.
- Inspect the Drum Cartridge Xerographic Connector.
- Cycle system power.

Procedure

WARNING

Switch off the electricity to the machine. Disconnect the power cord from the customer supply while performing tasks that do not need electricity. Electricity can cause death or injury. Moving parts can cause injury.

Check the Drum Cartridge life count. **Drum Cartridge life remains.**

Y N
| Replace the Drum Cartridge, REP 8.1.1 from customer stock.

Check Xerographic Connector condition. **The Xerographic Connector is good.**

Y N
| Replace the Xerographic Connector. **The error persists.**

Y N
| Perform SCP 6 Final Actions

Install new components as necessary:

- Xerographic Connector, REP 5.1.10
- MCU Board, REP 18.2.2

Replace the Drum Cartridge, REP 8.1.1 from customer stock.

92-661-00 Environment Temperature Sensor Fail

92-661-00 Environment Temperature Sensor Fail

Procedure

WARNING

Switch off the electricity to the machine. Disconnect the power cord from the customer supply while performing tasks that do not need electricity. Electricity can cause death or injury. Moving parts can cause injury.

Use dC140 code 091-200 to check environmental sensor operation. **The sensor is good.**

Y N
| Replace the HVPS, REP 18.2.5.

Install new components as necessary:

- MCU Board, REP 18.2.2

92-805-00 24V Fan Off Detect

92-584-00 24V fan off detect.

Initial Actions

- Clear vents of any dust accumulation.
- Cycle system power.

Procedure

WARNING

Switch off the electricity to the machine. Disconnect the power cord from the customer supply while performing tasks that do not need electricity. Electricity can cause death or injury. Moving parts can cause injury.

Use dC330 code 042-003 to test the LVPS Fan **The fan rotates.**

Y N
| Replace the LVPS Fan, REP 4.1.1.

Use dC140 code 091-200 to check environmental sensor operation. **The sensor is good.**

Y N
| Replace the HVPS, REP 18.2.5.

Install new components as necessary:

- LVPS Fan, REP 4.1.1.
- LVPS, REP 18.1.12
- MCU Board, REP 18.2.2

93-317-00 K Drum Cartridge Dispense Fail

93-317-00 K Drum Cartridge Dispense Fail

NOTE: Status codes 03-561 and 09-548 are raised with this fault code. .

Initial Actions

- Verify Toner Cartridge is genuine Xerox.
- Reseat and lock the Toner Cartridge.
- Cycle system power.

Procedure

WARNING

Switch off the electricity to the machine. Disconnect the power cord from the customer supply while performing tasks that do not need electricity. Electricity can cause death or injury. Moving parts can cause injury.

Check Toner Cartridge life count. **Toner Cartridge life remains.**

Y N
| Replace the Toner Cartridge, REP 8.1.2.

Remove and gently shake the Toner Cartridge. Replace the cartridge, then cycle system power and retest. **The error persists.**

Y N
| Perform SCP 6 Final Actions

Use dC330 code 093-001 to briefly test the Dispense Motor **The motor rotates.**

Y N
| Replace the Dispense Motor, REP 5.1.5.

Check Xerographic Connector condition. **The Xerographic Connector is good.**

Y N
| Replace the Xerographic Connector. **The error persists.**

Y N
| Perform SCP 6 Final Actions

Install new components as necessary:

- Toner Cartridge from customer stock, REP 8.1.2
- Drum Cartridge from customer stock, REP 8.1.1
- MCU Board, REP 18.2.2

Replace the Toner Cartridge, REP 8.1.2 from customer stock.

93-425-00, 93-912-00 K Toner Cartridge Life Near End

93-425-00 K Toner Cartridge Life Near End

93-912-00 K Toner Cartridge Life End

NOTE: Status code 09-501 is raised with these fault codes.

Initial Actions

- Verify Toner Cartridge is genuine Xerox.
- Reseat and lock the Toner Cartridge.
- Cycle system power.

Procedure

WARNING

Switch off the electricity to the machine. Disconnect the power cord from the customer supply while performing tasks that do not need electricity. Electricity can cause death or injury. Moving parts can cause injury.

Check Toner Cartridge life count. **The Toner Cartridge is at or near end of life.**

Y N
| Reseat and lock the Toner Cartridge, then cycle system power. **The error persists.**

Y N
| Perform SCP 6 Final Actions

Install new components as necessary:

- Toner Cartridge from customer stock, REP 8.1.2
- Toner CRUM Assembly, REP 5.1.99
- MCU Board, REP 18.2.2

Replace the Toner Cartridge, REP 8.1.2 from customer stock.

93-925-00, 93-926-00, 93-928-00 K Toner Cartridge Error

93-925-00 K Toner ID Error

93-926-00 K Toner Cartridge Data Error

93-928-00 K Toner Cartridge Comm Failure

NOTE: Status codes 03-561 and 09-548 are raised with these fault codes.

Initial Actions

- Verify Toner Cartridge is genuine Xerox.
- Inspect the Toner Cartridge CRUM connector.
- Cycle system power.

Procedure

WARNING

Switch off the electricity to the machine. Disconnect the power cord from the customer supply while performing tasks that do not need electricity. Electricity can cause death or injury. Moving parts can cause injury.

Check Toner Cartridge life count. **Toner Cartridge life remains.**

Y N
| Replace the Toner Cartridge, REP 8.1.2 from customer stock.

Check Toner CRUM Connector condition. **The Toner CRUM Assembly is good.**

Y N
| Replace the Toner CRUM Assembly. **The error persists.**

Y N
| Perform SCP 6 Final Actions

Install new components as necessary:

- Toner Cartridge from customer stock, REP 8.1.2
- Toner CRUM Assembly, REP 5.1.99
- MCU Board, REP 18.2.2

Replace the Toner Cartridge, REP 8.1.2 from customer stock.

93-938-00 CRUM Validation

93-938-00 Crum validation

Initial Actions

- Inspect the Toner Cartridge CRUM connector.
- Reseat and lock the Toner Cartridge.
- Cycle system power.

Procedure

WARNING

Switch off the electricity to the machine. Disconnect the power cord from the customer supply while performing tasks that do not need electricity. Electricity can cause death or injury. Moving parts can cause injury.

Check Toner CRUM Connector condition. **The Toner CRUM Assembly is good.**

Y N
| Replace the Toner CRUM Assembly. **The error persists.**

Y N
| Perform SCP 6 Final Actions

Install new components as necessary:

- Toner Cartridge from customer stock, REP 8.1.2
- Toner CRUM Assembly, REP 5.1.99
- MCU Board, REP 18.2.2

Replace the Toner Cartridge, REP 8.1.2 from customer stock.

93-973-00 Toner CRUM [K] Not in Position

93-973-00 Toner CRUM [K] not in position

NOTE: Status code 09-543 is raised with this fault code.

Initial Actions

- Verify Toner Cartridge is genuine Xerox.
- Reseat and lock the Toner Cartridge.
- Cycle system power.

Procedure

WARNING

Switch off the electricity to the machine. Disconnect the power cord from the customer supply while performing tasks that do not need electricity. Electricity can cause death or injury. Moving parts can cause injury.

Check Toner CRUM Connector condition. **The Toner CRUM Assembly is good.**

Y	N
	Replace the Toner CRUM Assembly. The error persists.
Y	N
	Perform SCP 6 Final Actions
	Install new components as necessary:
	• Toner Cartridge, REP 8.1.2
	• Toner CRUM Assembly, REP 5.1.99
	• MCU Board, REP 18.2.2

Replace the Toner Cartridge, REP 8.1.2 from customer stock.

94-419-00, 94-422-00 BTR Near Life End

94-419-00 BTR Near Life End

94-422-00 BTR Life End

NOTE: Status codes 94-320 and 94-300 respectively are raised with these fault codes.

Initial Actions

- Check Transfer Roller life count.
- Cycle system power.

Procedure

WARNING

Switch off the electricity to the machine. Disconnect the power cord from the customer supply while performing tasks that do not need electricity. Electricity can cause death or injury. Moving parts can cause injury.

WARNING

Do not touch the Fuser while it is hot.

Check Transfer Roller life count. **The Transfer Roller is at or near end of life.**

Y	N
	Install new components as necessary:
	• Transfer Roller, REP 6.1.1
	• MCU Board, REP 18.2.2

Replace the Transfer Roller, REP 6.1.1.

95-000-00 to 95-305-00 Upgrade Failure

One or more system software components has failed to upgrade.

95-000-00 Upgrade Failure : DC Boot Code

95-001-00 Upgrade Failure : SWUP Code

95-002-00 Upgrade Failure : DC Application

95-008-00 Upgrade Failure : DC operating System

95-009-00 Upgrade Failure : DC CIPS

95-016-00 Upgrade Failure : SUI Application

95-019-00 Upgrade Failure : SUI H8

95-020-00 Upgrade Failure : DADH Application

95-021-00 Upgrade Failure : External Memeory

95-022-00 Upgrade Failure : DADH Kernel

95-030-00 Upgrade Failure : Fax Application

95-031-00 Upgrade Failure : Fax FPGA

95-035-00 Upgrade Failure : Fax Boot

95-038-00 Upgrade Failure : Embedded Fax

95-040-00 Upgrade Failure : IOT Bootstrap

95-041-00 Upgrade Failure : IOT Boot Loader

95-042-00 Upgrade Failure : IOT Application

95-048-00 Upgrade Failure : IOT Duplex Module

95-049-00 Upgrade Failure : IOT LC Module

95-050-00 Upgrade Failure : LCSS 1K Application

95-060-00 Upgrade Failure : LCSS 2K Application

95-065-00 Upgrade Failure : LCSS 2K Boot

95-070-00 Upgrade Failure : LCSS 3K Application

95-100-00 Upgrade Failure : HCSS BO HCSS Application

95-110-00 Upgrade Failure : HCSS BO Application

95-140-00 Upgrade Failure : DC NC Application

95-141-00 Upgrade Failure : DC NC Operation System

95-150-00 Upgrade Failure : IIT Application

95-151-00 Upgrade Failure : Embedded Fax Application

95-153-00 Upgrade Failure : IIT Kernel

95-154-00 Upgrade Failure : IIT A4 Scan

95-155-00 Upgrade Failure : IIT CCD Module

95-156-00 Upgrade Failure : IIT FW TES Module

95-157-00 Upgrade Failure : DADH Quiet 100 Sheet Module

95-158-00 Upgrade Failure : DADH 100 Sheet Module

95-159-00 Upgrade Failure : DADH Quiet Module

95-170-00 Upgrade Failure : Scanner

95-180-00 Upgrade Failure : HCF FW Module

95-190-00 Upgrade Failure : PFM FW Module

95-191-00 Upgrade Failure : PFP FW Module

95-192-00 Upgrade Failure : HVF Application

95-193-00 Upgrade Failure : HVF BM Application

95-194-00 Upgrade Failure : HVF BC

95-195-00 Upgrade Failure : HVF BM BC

95-196-00 Upgrade Failure : PFP BL

95-200-00 Upgrade Failure : C Finisher Application

95-201-00 Upgrade Failure : D Finisher Application

95-202-00 Upgrade Failure : KM Finisher Application

95-203-00 Upgrade Failure : A Finisher Application

95-204-00 Upgrade Failure : SB Finisher Application

- 95-206-00 Upgrade Failure PFM Tray 3 Application
- 95-207-00 Upgrade Failure : PFM Tray 4 Application
- 95-208-00 Upgrade Failure : PFM Tray 5 Application
- 95-212-00 Upgrade Failure : DC IOT Proxy
- 95-213-00 Upgrade Failure : DC IIT Proxy
- 95-214-00 Upgrade Failure : DC ACD
- 95-216-00 Upgrade Failure : DC Glue
- 95-217-00 Upgrade Failure : DC PWS Proxy
- 95-218-00 Upgrade Failure : SS Boot Code
- 95-219-00 Upgrade Failure : SS Application
- 95-221-00 Upgrade Failure : LVF Boot
- 95-222-00 Upgrade Failure : LVF Application
- 95-223-00 Upgrade Failure : LVF BM Boot
- 95-224-00 Upgrade Failure : LVF BM Application
- 95-251-00 Upgrade Failure : DC Nomad Proxy
- 95-254-00 Upgrade Failure : DC URD
- 95-255-00 Upgrade Failure : DC SCD

Procedure

WARNING

Ensure that the electricity to the machine is switched off while performing tasks that do not need electricity. Disconnect the power cord. Electricity can cause death or injury. Moving parts can cause injury.

Obtain a current system software set, then perform GP 9 to reload system software. **The error persists.**

Y	N
Perform SCP 6 Final Actions.	

Perform a Forced AltBoot GP 9 to reload system software.

95-300-00 to 95-302-00 Upgrade Failure : Incompatible Product

95-300-00 Upgrade Failure : Incompatible Product

95-301-00 Upgrade Failure : Incompatible HW

95-302-00 Upgrade Failure : Incompatible FW

The reload process does not start and the printer resets. If configured, an email alert is sent and upgrade report printed. An entry is made in Upgrade History log.

Procedure

WARNING

Ensure that the electricity to the machine is switched off while performing tasks that do not need electricity. Disconnect the power cord. Electricity can cause death or injury. Moving parts can cause injury.

Verify product model, then obtain the appropriate system software set and perform GP 9 to reload system software. **The error persists.**

Y	N
Perform SCP 6 Final Actions.	

Perform a Forced AltBoot GP 9 to reload system software.

95-303-00, 95-304-00 Upgrade Failure: Downgrade / Sidegrade

95-303-00 Upgrade Failure : Downgrade

95-304-00 Upgrade Failure : Sidegrade

The reload process does not start and the printer resets. If configured, an email alert is sent and upgrade report printed. An entry is made in Upgrade History log.

Procedure

WARNING

Ensure that the electricity to the machine is switched off while performing tasks that do not need electricity. Disconnect the power cord. Electricity can cause death or injury. Moving parts can cause injury.

Obtain a current system software set, then perform GP 9 to reload system software. **The error persists.**

Y N
| Perform SCP 6 Final Actions.

Perform a Forced AltBoot GP 9 to reload system software.

95-305-00 Upgrade Failure: Platform Sync

95-305-00 Upgrade Failure : Platform Sync

The reload process does not start and the printer resets. If configured, an email alert is sent and upgrade report printed. An entry is made in Upgrade History log.

Procedure

WARNING

Ensure that the electricity to the machine is switched off while performing tasks that do not need electricity. Disconnect the power cord. Electricity can cause death or injury. Moving parts can cause injury.

Obtain a current system software set, then perform GP 9 to reload system software. **The error persists.**

Y N
| Perform SCP 6 Final Actions.

Perform a Forced AltBoot GP 9 to reload system software.

OF 1 Unusual Noises

Use this procedure to isolate unusual noises.

NOTE: Due to the intermittent nature of unusual noises, this RAP can only give guidance on how to isolate noises. This RAP will not find all possible causes. When machines become old and worn, unusual noises may arise that are not covered in this RAP.

Procedure

WARNING

Ensure that the electricity to the machine is switched off while performing tasks that do not need electricity. Disconnect the power cord. Electricity can cause death or injury. Moving parts can cause injury.

1. Ask the customer to demonstrate the function that generates the unusual noise.
2. Check the fault and error logs.
3. Cycle system power. Wait while the printer performs a normal initialization and warm-up.
4. Run the machine in all modes. Also use the diagnostics to run individual components. Go to the relevant subsection:
 - DADF
 - Scanner
 - Bypass Tray
 - Tray 1
 - Optional Feeder Assembly
 - Exit Path
 - Fans

DADF

Possible causes and potential solutions are:

- **Grinding noise.**
Possible causes are:
 - Feed bearinga can stick, preventing the feed roll from free wheeling as the document is transported.
 - Large flat spots, confined to one or two areas on the retard roll, which causes feed noise and an increase in jams.Solution:
 - Install a new Pick-up Module, PL 21.1 Item 97.
 - Replace the DADF, REP 21.1.1.
- **Noise from the DADH input tray.**
Possible causes are:
 - Document guides.Solution:
 - Clean the DADF input tray in the area below the input guides with antistatic fluid.
- **Squeaks from the DADH.**
Possible causes are:
 - DADF exit roll assembly or take away roll assembly.

Solution:

- Remove and clean the shafts and plastic bushes with antistatic fluid.

- **Knocking noise.**

Possible causes are:

- The feed motor not tensioned correctly, causing the drive belts to slip.

Solution:

- Replace the DADF, REP 21.1.1.

- **Gear rattle.**

Possible causes are:

- A loose meshing of the clutch and motor gears.

Solution:

- Replace the DADF, REP 21.1.1.

Scanner

Possible causes and potential solutions are:

- **Grinding.**

Possible causes are:

- The scan carriage is moving erratically and the scan motor is generating a grinding sound. The teeth of the scanner drive belt are not engaging with the capstan on the scan motor.

Solution:

- Replace the Scanner, REP 21.1.14.

Bypass Tray

Run the following components:

- Combine dC330 code 071.001, Main Drive Assembly, and 071.004, MSI Feed Solenoid to test Bypass Tray feed components.

Possible causes and potential solutions are:

- **No drive or a knocking noise.**

Possible causes are:

- Incorrectly aligned or damaged parts.
- Contamination of the drive shafts and the bearings.

Solution:

- Check the Bypass Pick-up Assembly, PL 13.1 Item 15.
- Adjust or install new components as necessary.

Tray 1

Remove Tray 1 and run the following components:

- Enter dC330 code 071.001 to run the Main Drive Assembly.

Possible causes and potential solutions are:

- **Squeaks.**

Possible causes are:

- Contamination of the Transport Assembly shafts and bearings.
- Incorrectly aligned or damaged parts.

Solution:

- Clean the Feed Rollers and shafts. Replace if necessary, REP 9.2.98.

- Check Transport Assembly. Install new parts as necessary, PL 15.2.
- Check the Tray for parts that are damaged or out of position.
- Adjust or install new components as necessary.

Optional Feeder Assembly

NOTE: Instructions are provided for Tray 2. Troubleshoot other Optional Feeder Assemblies using the codes applicable to the Optional Feeder under test.

Remove Tray 2 and run the following components:

- Enter dC330 code 071.009 to operate the Tray 2 Feed Motor, PL 11.1 Item 7.
- Check tray lift by removing the tray and letting the tray drop, then push the tray back in.

Possible causes and potential solutions are:

- **No drive or a knocking noise from the Feed Motor.**

Possible causes are:

- Feed Motor, PL 11.1 Item 7
- Worn drive gears
- Failed Feed Clutch, PL 11.1 Item 8

Solution:

- Check the Feed Motor and Feed Clutch connections.
- Check the Optional Feeder Assembly connection to the printer.
- Check that the tray moves freely inside the feeder assembly.
- Adjust or install new components as necessary.

Exit Path

Run the following components:

- Combine dC330 code 071.001 Main Drive Assembly and 071.007 exit clutch to run the exit transport.
- Combine dC330 code 071.001 Main Drive Assembly) and 071.008 exit invert clutch to run the duplex transport. Used for duplex and paper invert.

Possible causes:

- Exit Drive Assembly, PL 3.1 Item 2
- Exit Invert Drive Assembly, PL 3.1 Item 3
- Exit Chute Assembly, PL 17.1 Item 99

Solution:

- If the noise repeats, identify the source and install new parts as necessary.

Fans

Run the following components:

- Enter dC330 code 042.001 to run the Rear Fan.
- Enter dC330 code 042.003 to run the LVPS Fan.

Possible causes:

- Bearings in the cooling fans have worn or failed.
- Incorrectly aligned or damaged parts.

Solution:

- Check for parts that are damaged or out of position.
- Adjust or install new components as necessary.

OF 2 Control Panel Touch Screen Failure

Use this procedure to solve Control Panel display problems when the printer has power but either the display is blank, is too dark, or the touch screen responds incorrectly.

Initial Actions

WARNING

Ensure that the electricity to the machine is switched off while performing tasks that do not need electricity. Disconnect the power cord. Electricity can cause death or injury. Moving parts can cause injury.

- Refer to GP 1 to access Service Diagnostics.
- Press the Machine Status key. Select the Tools tab. Select Device Settings, then Display Brightness. Adjust the brightness level.
- Refer to REP 1.2.1 to access Control Panel wiring.
- Check and re-seat the Control Panel cable at both ends.
- If the operating system fails to boot, observe the progress bar to determine the failure.
 - Yellow progress bar = XUI code booting up.
 - Non moving green bar = Code loaded but not communicating.
 - Moving green bar = ESS Board is operational and is trying to communicate.

Go to **OF 7** to check input power

Procedure

Check for +3.3V on the ESS Board from RA 2303 to RA2311 as shown in Figure 1. **+3.3V is measured.**

Y N

Check the wiring between the ESS Board and Control Panel. Repair the wiring as necessary.

Reload the system software, GP 9. **The fault remains.**

Y N

Perform SCP 5 Final Actions.

Replace the Control Panel, REP 1.2.1.

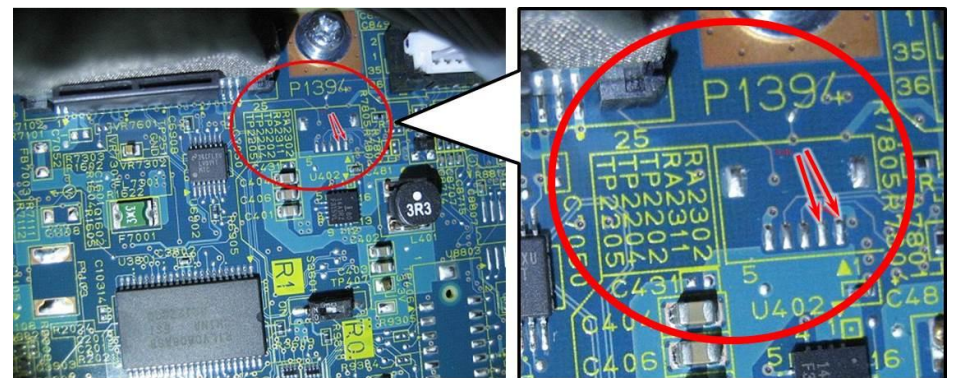

Figure 1

OF 3 Status Codes and Messages

The status code format is HCC-LLL-EE where HCC is the chain, LLL is the link and EE is the extension number. The hundreds digit H is not shown in this procedure.

Example: Status code 01-510-00 Front door is open.

Most recent fault and messages can be displayed on the UI without entering diagnostics, by pressing the Machine Status button on the keypad, touching the Fault tab on the UI, then select as appropriate:

- Current Faults.
- Current Messages.
- Fault History.

The following tables bring together the status codes, the relevant RAP or procedure references, and UI messages, if generated.

NOTE: Not all status codes are shown in the active message window. Some status codes have no messages.

Procedure

Review fault code history, GP 2 and identify and clear any active faults. Use these tables to identify a status code or message:

Status Code Tables

- Table 1 Chain 01 Status codes
- Table 2 Chain 02 Status codes
- Table 3 Chain 03 Status codes
- Table 4 Chain 04 Status codes
- Table 5 Chain 05 Status codes
- Table 6 Chain 06 Status codes
- Table 7 Chain 07 Status codes
- Table 8 Chain 09 Status codes
- Table 9 Chain 10 Status codes
- Table 10 Chain 14 Status codes
- Table 11 Chain 15 Status codes
- Table 12 Chain 16 Status codes
- Table 13 Chain 17 Status codes
- Table 14 Chain 19 Status codes
- Table 15 Chain 20 Status codes
- Table 16 Chain 22 Status codes
- Table 17 Chain 72 to 77 Status codes
- Table 18 Chain 91 to 95 Status codes

Table 1 Chain 01 Status codes

Code	UI Message	Reason for Message	Reference / Action
01-510-00	Front door is open	The front door is open.	Copying and printing are not available. Perform the 77-300-00 Front Door Open
01-516-00	Rear Door Open.	Printer rear door interlock open.	Copying and printing are not available. Perform the 77-301-00 Rear Door Open
01-540-01	Check the settings for tray 1	Paper removed or added to tray 1	Confirm the tray 1 settings
01-540-02	Check the settings for tray 2	Paper removed or added to tray 2	Confirm the tray 2 settings
01-540-05	Check the settings for Bypass Tray	Paper removed or added to Bypass Tray	Confirm Bypass Tray settings
01-541-01	Tray 1 guides are not set to a standard size.	tray 1 guide setting	Paper guide position does not support a standard paper size. Adjust paper guides.
01-541-02	Tray 2 guides are not set to a standard size.	tray 2 guide setting	Paper guide position does not support a standard paper size. Adjust paper guides.
01-541-03	Tray 3 guides are not set to a standard size.	Bypass Tray guide setting	Paper guide position does not support a standard paper size. Adjust paper guides.
01-541-04	Tray 4 guides are not set to a standard size.	tray 4 guide setting	Paper guide position does not support a standard paper size. Adjust paper guides.
01-541-05	Bypass Tray guides are not set to a standard size.	tray 4 guide setting	Paper guide position does not support a standard paper size. Adjust paper guides.
01-545-01	Tray 1 guides are not set properly	Dedicated tray 1 closed with media size other than what was set	Reload the required paper and correctly adjust the paper guides
01-545-02	Tray 2 guides are not set properly	Dedicated tray 2 closed with media size other than what was set	Reload the required paper and correctly adjust the paper guides
01-545-03	Tray 3 guides are not set properly	Dedicated tray 3 closed with media size other than what was set	Reload the required paper and correctly adjust the paper guides
01-545-04	Tray 4 guides are not set properly	Dedicated tray 4 closed with media size other than what was set	Reload the required paper and correctly adjust the paper guides
01-550-00	-	NC status code - system is in power save mode	Printing will start when a job is received or a user initiates a job at the machine

Table 1 Chain 01 Status codes

Code	UI Message	Reason for Message	Reference / Action
01-551-00	-	NC status code - system is in sleep mode	Printing will start when a job is received or a user initiates a job at the machine

Table 2 Chain 02 Status codes

Code	UI Message	Reason for Message	Reference / Action
02-501-00	-	Control Panel USB communication error.	Cycle system power. If the error persists, perform 02-380-00, 02-381-00 UI Communication Fault.
02-502-00	-	Control Panel USB communication error.	Cycle system power. If the error persists, perform 02-380-00, 02-381-00 UI Communication Fault.
02-516-00	System Error. Power Off then On and notify system administrator.	Incomplete System Information.	Cycle system power.
02-517-00	A Supplies Plan Activation Code must be entered soon.	PagePack Grace Period Active	The printer is in the Supplies Plan courtesy period. Enter a valid activation code.
02-518-00	Courtesy Prints are depleted. Print services are disabled.	PagePack Grace Period Expired	Supplies Plan courtesy prints are depleted. Enter a valid activation code.
02-520-00	The device is not available	A software error has occurred.	Cycle system power. If the error persists, perform 02-320-00 Data Time Out Error.
02-521-00	-	The XEIP browser is dead or not responding	Cycle system power. If the error persists, perform 02-321-00 XEIP Browser Does not Respond.
02-590-00	Machine power on failed. Power off then on and notify system administrator	Configurable services are not stable at power on	Cycle system power. If the error persists, perform 02-390-00 Configurable Services Not Stable.

Table 3 Chain 03 Status codes

Code	UI Message	Reason for Message	Reference / Action
03-504-00	The device is offline	NC status code	Cycle system power.
03-504-01	The device is offline	NC status code	Cycle system power.
03-505-00	System error. Power off then on and notify system administrator	The digital copier is not available	Cycle system power. If the error persists, perform 03-316-00, 03-325-00, 03-355-00.

Table 3 Chain 03 Status codes

Code	UI Message	Reason for Message	Reference / Action
03-506-00	No message	Copy Activity Report is Printing	No action needed.
03-516-00	Scan and Copy Services not available. Print Service is available.	Scanner Not Available	Cycle system power.
03-518-00	Network controller not available. Power off then on and notify system administrator	The network controller is not available.	Cycle system power. If the error persists, perform 03-331-00, 03-332-00 Communication Fault with NC
03-520-00	No message	CCM to UI communication not established in 30 sec	Cycle system power. If the error persists, perform 03-346-00, 03-347-00 Communication Fault with UI.
03-521-00	No message	CCM to UI communication are lost	Cycle system power. If the error persists, perform 03-346-00, 03-347-00 Communication Fault with UI.
03-535-00	Diagnostics are active. The system is not available. Please wait.	Machine has entered non-intrusive diagnostic mode	-
03-536-00	Diagnostics are active. The system is not available. Please wait.	The machine has entered intrusive diagnostic mode	-
03-536-01	Diagnostics are active. The system is not available. Please wait.	The machine has entered intrusive diagnostic mode via the PWS	-
03-546-00	Incompatible Fax software detected (upgrade required)	Incompatible Fax software detected at power on	Perform 03-417-00 Incompatible FAX Software Detected.
03-547-00	A Fax service error has occurred. Power off then on	Basic Fax not detected or confirmed	Cycle system power. If the error persists, perform 03-401-00, 03-403-00 FAX Not Detected.
03-548-00	Fax line 2 is unavailable. Notify your system administrator.	Extended Fax not detected or confirmed	Cycle system power. If the error persists, perform 03-401-00, 03-403-00 FAX Not Detected.
03-549-00	Fax memory error. Power off then on and notify system administrator	Fax POST failure status	Cycle system power.

Table 3 Chain 03 Status codes

Code	UI Message	Reason for Message	Reference / Action
03-550-00	A Fax service error has occurred. Power Off then On	Fax card is unavailable	Cycle system power. If the error persists, perform 20-302-00 to 20-305-00 Fax Board Hardware or Software error.
03-551-00	A Fax Service error has occurred. Power Off then On	Fax service is unavailable	Cycle system power. If the error persists, perform 20-331-00 to 20-341-00 Fax Network Line 1 Fault
03-557-00	Please wait... The Scanner is attempting to recover.	Power on while the IIT is being initialized	Cycle system power. If the error persists, perform 62-311-00 to 62-389-00 IIT Scan Error.
03-558-00	Please complete all steps required by the external accounting device to access this service	Not defined	-
03-558-01	Please insert card into the external accounting device to access this service	Not defined	-
03-558-02	Please enter access code into external accounting device to access this service	Not defined	-
03-558-03	Please insert money into the external accounting device to access this service	Not defined	-
03-558-04	Please insert key counter into the external accounting device to access this service	Not defined	-
03-561-00	Please wait... the system is attempting to recover	The system is recovering	Wait until the system recovers. If the error persists, perform 10-311-00 to 10-376-00 Fuser Thermal Errors
03-562-00	Some jobs may have been deleted	When some jobs may have been deleted	Removed upon user intervention
03-563-00	The network controller is initializing. Copy and print jobs may be delayed	Network service are being established	Wait until the system recovers. If the error persists, perform, perform the 03-331-00, 03-332-00 Communication Fault with NC

Table 3 Chain 03 Status codes

Code	UI Message	Reason for Message	Reference / Action
03-564-00	Image rotation is not available. Power off then on and notify system administrator	Image rotation is not available	Cycle system power. If the error persists, review fault code history to identify failed component.
03-565-00	System error. Power off them on and notify system administrator	System fault	Cycle system power. If the error persists, review fault code history to identify failed component.
03-578-00	System Error. Power Off then On and Notify System Administrator	Paper Tray error	Cycle system power. If the error persists, review fault code history to identify failed component.
03-589-00	Tray 3 is not available. Notify your System Administrator	Paper Tray error	Cycle system power. If the error persists, perform 73-215-00 Tray 3 Feeder Composition Error.
03-581-00	System Error. Power Off then On and Notify System Administrator	Paper Tray error	Cycle system power. If the error persists, review fault code history to identify failed component.
03-587-00	Tray 1 is not available. Notify your System Administrator	Paper Tray error	Cycle system power. If the error persists, perform 71-215-00 Tray 1 Feeder Composition Error
03-588-00	Tray 2 is not available. Notify your System Administrator	Paper Tray error	Cycle system power. If the error persists, perform 72-215-00 Tray 2 Feeder Composition Error.
03-590-00	Tray 4 is not available. Notify your System Administrator	Paper Tray error	Cycle system power. If the error persists, perform 74-215-00 Tray 4 Feeder Composition Error.
03-597-00	Communication error. Power off then on and notify system administrator	The document feeder is not available. Use the document glass	Cycle system power. If the error persists, perform 05-110-00 DADF Pickup Jam
03-598-00	System Error. Power Off then On and notify system administrator.	Unable to set Ready mode	Cycle system power. If the error persists, perform 03-788-00 Failed to Exit Power Save Mode

Table 4 Chain 04 Status codes

Code	UI Message	Reason for Message	Reference / Action
04-561-00	System error. Power off then on and notify system administrator	Software Logic Failure	Cycle system power. If the error persists, perform 41-388-00 Marking Logic Fail
04-563-00	System error. Power off then on and notify system administrator	Image module system fault/ hardware failure	Cycle system power. If the error persists, review fault code history to identify failed component.
04-565-00	System error. Power off then on and notify system administrator	IME controller communication failure	Cycle system power. If the error persists, perform 45-301-00 to 45-305-00 IOT I/F Error
04-566-00	System error. Power off then on and notify system administrator	IME controller communication failure	Cycle system power. If the error persists, perform 45-301-00 to 45-305-00 IOT I/F Error
04-567-00	Output tray Offsetting is not available. Power Off then On and Notify System Administrator.	OCT offset failure occurred	Cycle system power. If the error persists, review fault code history to identify failed component.
04-568-00	The output tray is full. Empty the output tray	The OCT is full.	Empty the tray.

Table 5 Chain 05 Status codes

Code	UI Message	Reason for Message	Reference / Action
05-501-00	The document feeder is open	Document feeder is up.	Close the DADH. If the error persists, perform 05-900-00 ADF Sensor Static Jam
05-502-00	The document feeder top cover is open	The DADH top cover is open.	Close the DADH top cover. If the error persists, perform 05-900-00 ADF Sensor Static Jam
05-506-00	Paper Jam in the Document Feeder.	Document Feeder Jam.	Clear the jam. If the error persists, perform 05-121-00 CVT-DADF Feed Sensor On Jam
05-525-00	No message	The Document feeder tray is empty	Cycle system power. If the error persists, perform 05-940-00 DADF No Original Fail
05-535-00	No message	Document feeder tray loaded	-

Table 5 Chain 05 Status codes

Code	UI Message	Reason for Message	Reference / Action
05-570-00	Reload sheets in Document Feeder.	DADF jam clearance.	Re-sort and reload the document originals. Cycle system power. If the error persists, perform 05-940-00 DADF No Original Fail
05-575-00	The number of originals was less than the number originally scanned.	Paper jam in the Document Feeder.	Re-sort and reload the document originals. Cycle system power. If the error persists, perform 05-940-00 DADF No Original Fail

Table 6 Chain 06 Status codes

Code	UI Message	Reason for Message	Reference / Action
06-515-00	Imaging Error. Power Off then On and Notify System Administrator	Unclearable Laser Unit fault	Cycle system power. If the error persists, perform 62-311-00 to 62-389-00 ROS Error

Table 7 Chain 07 Status codes

Code	UI Message	Reason for Message	Reference / Action
07-501-03	Tray 1 paper jam.	Misfeed in Tray 1	Paper jam in Bypass and Tray 1 area. User intervention is required to clear the jam. If error persists, perform 71-101-00 Tray1 Misfeed Jam
07-501-04	Tray 1 paper jam.	Misfeed in Tray 1	Paper jam in Bypass and Tray 1 area. User intervention is required to clear the jam. If error persists, perform 71-101-00 Tray1 Misfeed Jam
07-502-01	Tray 2 paper jam.	Misfeed in Tray 2	Paper jam in Tray 2. User intervention needed to clear the jam. If error persists, perform 72-101-00 Tray2 Misfeed Jam
07-502-02	Tray 2 paper jam.	Misfeed in Tray 2	Paper jam in Tray 2. User intervention needed to clear the jam. If error persists, perform 72-101-00 Tray2 Misfeed Jam

Table 7 Chain 07 Status codes

Code	UI Message	Reason for Message	Reference / Action
07-502-03	Tray 2 paper jam.	Misfeed in Tray 2	Paper jam in Tray 2. User intervention needed to clear the jam. If error persists, perform 72-101-00 Tray2 Misfeed Jam
07-502-04	Tray 2 paper jam.	Misfeed in Tray 2	Paper jam in Tray 2. User intervention needed to clear the jam. If error persists, perform 72-101-00 Tray2 Misfeed Jam
07-503-01	Tray 3 paper jam.	Misfeed in Tray 3	Paper jam in Tray 3. User intervention needed to clear the jam. If error persists, perform 73-101-00 Tray3 Misfeed Jam
07-503-02	Tray 3 paper jam.	Misfeed in Tray 3	Paper jam in Tray 3. User intervention needed to clear the jam. If error persists, perform 73-101-00 Tray3 Misfeed Jam
07-503-03	Tray 3 paper jam.	Misfeed in Tray 3	Paper jam in Tray 3. User intervention needed to clear the jam. If error persists, perform 73-101-00 Tray3 Misfeed Jam
07-503-04	Tray 3 paper jam.	Misfeed in Tray 3	Paper jam in Tray 3. User intervention needed to clear the jam. If error persists, perform 73-101-00 Tray3 Misfeed Jam
07-504-01	Tray 4 paper jam.	Misfeed in Tray 4	Paper jam in Tray 4. User intervention needed to clear the jam. If error persists, perform 74-101-00 Tray4 Misfeed Jam
07-504-02	Tray 4 paper jam.	Misfeed in Tray 4	Paper jam in Tray 4. User intervention needed to clear the jam. If error persists, perform 74-101-00 Tray4 Misfeed Jam.
07-504-03	Tray 4 paper jam.	Misfeed in Tray 4	Paper jam in Tray 4. User intervention needed to clear the jam. If error persists, perform 74-101-00 Tray4 Misfeed Jam
07-504-04	Tray 4 paper jam.	Misfeed in Tray 4	Paper jam in Tray 4. User intervention needed to clear the jam. If error persists, perform 74-101-00 Tray4 Misfeed Jam
07-505-01	Bypass tray paper jam.	Misfeed in Bypass/MSI	Bypass Tray jam. User intervention needed to clear the jam. If error persists, perform 75-101-00 Bypass Misfeed Jam

Table 7 Chain 07 Status codes

Code	UI Message	Reason for Message	Reference / Action
07-505-02	Bypass tray paper jam.	Misfeed in Bypass/MSI	Bypass Tray jam. User intervention needed to clear the jam. If error persists, perform 75-101-00 Bypass Misfeed Jam
07-505-03	Bypass tray paper jam.	Misfeed in Bypass/MSI	Bypass Tray jam. User intervention needed to clear the jam. If error persists, perform 75-101-00 Bypass Misfeed Jam
07-505-04	Bypass tray paper jam.	Misfeed in Bypass/MSI	Bypass Tray jam. User intervention needed to clear the jam. If error persists, perform 75-101-00 Bypass Misfeed Jam
07-506-01	Paper jam behind Rear Door.	Jam behind Tray 2 and Tray 3 rear cover	Paper jam behind Rear Cover. User must clear the jam. If error persists, perform 73-102-00 Feeder Path 3 Sensor On Jam (RC3)
07-506-02	Paper jam behind Rear Door.	Jam behind Tray 2 and Tray 3 rear cover	Paper jam behind Rear Cover. User must clear the jam. If error persists, perform 73-102-00 Feeder Path 3 Sensor On Jam (RC3)
07-506-03	Paper jam behind Rear Door.	Jam behind Tray 2 and Tray 3 rear cover	Paper jam behind Rear Cover. User must clear the jam. If error persists, perform 73-102-00 Feeder Path 3 Sensor On Jam (RC3)
07-506-04	Paper jam behind Rear Door.	Jam behind Tray 2 and Tray 3 rear cover	Paper jam behind Rear Cover. User must clear the jam. If error persists, perform 73-102-00 Feeder Path 3 Sensor On Jam (RC3)
07-507-01	Paper jam behind Rear Door.	Jam behind Tray 3 rear cover	Paper jam behind Rear Cover. User must clear the jam. If error persists, perform 73-102-00 Feeder Path 3 Sensor On Jam (RC3)
07-507-02	Paper jam behind Rear Door.	Jam behind Tray 3 rear cover	Paper jam behind Rear Cover. User must clear the jam. If error persists, perform 73-102-00 Feeder Path 3 Sensor On Jam (RC3)
07-507-03	Paper jam behind Rear Door.	Jam behind Tray 3 rear cover	Paper jam behind Rear Cover. User must clear the jam. If error persists, perform 73-102-00 Feeder Path 3 Sensor On Jam (RC3)

Table 7 Chain 07 Status codes

Code	UI Message	Reason for Message	Reference / Action
07-507-04	Paper jam behind Rear Door.	Jam behind Tray 3 rear cover	Paper jam behind Rear Cover. User must clear the jam. If error persists, perform 73-102-00 Feeder Path 3 Sensor On Jam (RC3)
07-508-01	Paper jam behind Rear Door.	Jam behind Tray 2 rear cover	Paper jam behind Rear Cover. User must clear the jam. If error persists, perform 72-102-00 Feeder Path 2 Sensor On Jam (RC2)
07-508-02	Paper jam behind Rear Door.	Jam behind Tray 2 rear cover	Paper jam behind Rear Cover. User must clear the jam. If error persists, perform 72-102-00 Feeder Path 2 Sensor On Jam (RC2)
07-508-03	Paper jam behind Rear Door.	Jam behind Tray 2 rear cover	Paper jam behind Rear Cover. User must clear the jam. If error persists, perform 72-102-00 Feeder Path 2 Sensor On Jam (RC2)
07-508-04	Paper jam behind Rear Door.	Jam behind Tray 2 rear cover	Paper jam behind Rear Cover. User must clear the jam. If error persists, perform 72-102-00 Feeder Path 2 Sensor On Jam (RC2)
07-509-01	Paper jam behind Rear Door.	Jam in Fuser area	Paper jam behind Rear Cover. User must clear the jam.
07-509-02	Paper jam behind Rear Door.	Jam in Fuser area	Paper jam behind Rear Cover. User must clear the jam.
07-509-03	Paper jam behind Rear Door.	Jam in Fuser area	Paper jam behind Rear Cover. User must clear the jam.
07-509-04	Paper jam behind Rear Door.	Jam in Fuser area	Paper jam behind Rear Cover. User must clear the jam.
07-510-01	Paper jam behind Rear Door.	Jam in registration area	Paper jam behind Rear Cover. User must clear the jam. If error persists, perform 77-900-00 IOT Static Jam
07-510-02	Paper jam behind Rear Door.	Jam in registration area	Paper jam behind Rear Cover. User must clear the jam. If error persists, perform 77-900-00 IOT Static Jam
07-510-03	Paper jam behind Rear Door.	Jam in registration area	Paper jam behind Rear Cover. User must clear the jam. If error persists, perform 77-900-00 IOT Static Jam

Table 7 Chain 07 Status codes

Code	UI Message	Reason for Message	Reference / Action
07-510-04	Paper jam behind Rear Door.	Jam in registration area	Paper jam behind Rear Cover. User must clear the jam. If error persists, perform 77-900-00 IOT Static Jam
07-511-01	Paper jam behind Rear Door.	Jam in duplex area	Paper jam behind Rear Cover. User must clear the jam. If error persists, perform 77-123-00 Duplex Regi On Jam
07-511-02	Paper jam behind Rear Door.	Jam in duplex area	Paper jam behind Rear Cover. User must clear the jam. If error persists, perform 77-123-00 Duplex Regi On Jam
07-511-03	Paper jam behind Rear Door.	Jam in duplex area	Paper jam behind Rear Cover. User must clear the jam. If error persists, perform 77-123-00 Duplex Regi On Jam
07-511-04	Paper jam behind Rear Door.	Jam in duplex area	Paper jam behind Rear Cover. User must clear the jam. If error persists, perform 77-123-00 Duplex Regi On Jam
07-513-01	Tray 1 is open	Dedicated tray 1 is open	Cycle system power. If the error persists, review fault code history to identify failed component.
07-513-02	Tray 2 is open	Dedicated tray 2 is open	Cycle system power. If the error persists, review fault code history to identify failed component.
07-513-03	Tray 3 is open	Dedicated tray 3 is open	Cycle system power. If the error persists, review fault code history to identify failed component.
07-513-04	Tray 4 is open	Dedicated tray 4 is open	Cycle system power. If the error persists, review fault code history to identify failed component.
07-514-01	Tray 1 is open	Adjustable tray 1 is open	Cycle system power. If the error persists, review fault code history to identify failed component.
07-514-02	Tray 2 is open	Adjustable tray 2 is open	Cycle system power. If the error persists, review fault code history to identify failed component.
07-514-03	Tray 3 is open	Adjustable tray 3 is open	Cycle system power. If the error persists, review fault code history to identify failed component.
07-514-04	Tray 4 is open	Adjustable tray 4 is open	Cycle system power. If the error persists, review fault code history to identify failed component.

Table 7 Chain 07 Status codes

Code	UI Message	Reason for Message	Reference / Action
07-520-01	Paper Jam in Paper tray area.	Optional tray - Static jam Regi	Paper jam behind Rear Cover. User must clear the jam. If error persists, perform 77-901-00 Feeder Static Jam
07-520-02	Paper Jam in Paper tray area.	Optional tray - Static jam Regi	Paper jam behind Rear Cover. User must clear the jam. If error persists, perform 77-901-00 Feeder Static Jam
07-520-03	Paper Jam in Paper tray area.	Optional tray - Static jam Regi	Paper jam behind Rear Cover. User must clear the jam. If error persists, perform 77-901-00 Feeder Static Jam
07-520-04	Paper Jam in Paper tray area.	Optional tray - Static jam Regi	Paper jam behind Rear Cover. User must clear the jam. If error persists, perform 77-901-00 Feeder Static Jam
07-522-01	Paper Jam in Paper tray area.	Static Jam in optional tray regi area	Paper jam behind Rear Cover. User must clear the jam. If error persists, perform 77-101-00 Regi Off Jam
07-522-02	Paper Jam in Paper tray area.	Static Jam in optional tray regi area	Paper jam behind Rear Cover. User must clear the jam. If error persists, perform 77-101-00 Regi Off Jam
07-522-03	Paper Jam in Paper tray area.	Static Jam in optional tray regi area	Paper jam behind Rear Cover. User must clear the jam. If error persists, perform 77-101-00 Regi Off Jam
07-522-04	Paper Jam in Paper tray area.	Static Jam in optional tray regi area	Paper jam behind Rear Cover. User must clear the jam. If error persists, perform 77-101-00 Regi Off Jam
07-524-01	Paper Jam in Paper tray area.	Jam behind trays 2-4	Paper jam behind Rear Cover. User must clear the jam. If error persists, perform 77-101-00 Regi Off Jam
07-524-02	Paper Jam in Paper tray area.	Jam behind trays 2-4	Paper jam behind Rear Cover. User must clear the jam. If error persists, perform 77-101-00 Regi Off Jam
07-524-03	Paper Jam in Paper tray area.	Jam behind trays 2-4	Paper jam behind Rear Cover. User must clear the jam. If error persists, perform 77-101-00 Regi Off Jam

Table 7 Chain 07 Status codes

Code	UI Message	Reason for Message	Reference / Action
07-524-04	Jam behind trays 2-4	Static Jam in optional tray regi area	Paper jam behind Rear Cover. User must clear the jam. If error persists, perform 77-101-00 Regi Off Jam
07-533-00	Tray 3 is empty. Add paper.	Tray 3 is empty	Cycle system power. If the error persists, review fault code history to identify failed component.
07-534-00	Tray 4 is empty. Add paper.	Tray 4 is empty	Cycle system power. If the error persists, review fault code history to identify failed component.
07-535-00	Bypass Tray is empty. Add paper.	Bypass Tray is empty	Cycle system power. If the error persists, review fault code history to identify failed component.
07-544-00	Tray 1 is empty. Add paper.	Tray 1 is empty	Cycle system power. If the error persists, review fault code history to identify failed component.
07-545-00	Tray 2 is empty. Add paper.	Tray 2 is empty	Cycle system power. If the error persists, review fault code history to identify failed component.
07-546-01	Unexpected paper size or type detected from Tray 1	Tray 1 media or type mismatch detected	Cycle system power. If the error persists, review fault code history to identify failed component.
07-546-02	Unexpected paper size or type detected from Tray 2	Tray 2 media or type mismatch detected	Cycle system power. If the error persists, review fault code history to identify failed component.
07-546-03	Unexpected paper size or type detected from Tray 3	Tray 3 media or type mismatch detected	Cycle system power. If the error persists, review fault code history to identify failed component.
07-546-04	Unexpected paper size or type detected from Tray 4	Tray 4 media or type mismatch detected	Cycle system power. If the error persists, review fault code history to identify failed component.
07-546-05	Unexpected paper size or type detected from Bypass Tray	Bypass Tray media or type mismatch detected	Cycle system power. If the error persists, review fault code history to identify failed component.

Table 8 Chain 09 Status codes

Code	UI Message	Reason for Message	Reference / Action
09-503-00	The SMart Kit Drum Cartridge is not compatible.	SMart Kit Drum Cartridge is not compatible.	Cycle system power. If the error persists, perform 91-914-00 to 91-936-00 K Drum Cartridge Error

Table 8 Chain 09 Status codes

Code	UI Message	Reason for Message	Reference / Action
09-521-00	The SMart Kit Drum Cartridge needs replacement. Replace it NOW.	SMart Kit Drum Cartridge in is at end of life.	Cycle system power. If the error persists, perform 91-913-00 K Drum Cartridge Dead Stop Error
09-533-00	Reorder SMart Kit Drum Cartridge but DO NOT replace until prompted.	SMart Kit Drum Cartridge in is at end of life.	Cycle system power. If the error persists, perform 91-913-00 K Drum Cartridge Dead Stop Error
09-535-00	Drum Cartridge Error.	Drum Cartridge is missing or not in position.	Cycle system power. If the error persists, perform 91-913-00 K Drum Cartridge Dead Stop Error
09-543-00	Toner Cartridge is missing or not seated properly.	Tonor CRUM not in Position.	Cycle system power. If the error persists, perform 93-973-00 Toner CRUM [K] Not in Position
09-548-00	There is a problem with the Xerographic system. Call for assistance.	Xerographic system error.	Cycle system power. If the error persists, perform 91-914-00 to 91-936-00 K Drum Cartridge Error
09-553-00	Reorder SMart Kit Drum Cartridge but DO NOT replace until prompted.	SMart Kit Drum Cartridge error. Call for assistance.	Cycle system power. If the error persists, perform 91-914-00 to 91-936-00 K Drum Cartridge Error
09-561-00	Black Toner (K) is not compatible.	toner crum mismatch (K)	Cycle system power. If the error persists, perform 93-925-00, 93-926-00, 93-928-00 K Toner Cartridge Error
09-568-00	Reorder Toner but DO NOT replace until prompted.	Low Toner Cartridge but DO NOT replace until prompted.	Replace the Toner Cartridge. If the error persists, perform 93-425-00, 93-912-00 K Toner Cartridge Life Near End.
09-582-00	System Error. Power Off then On and notify system administrator.	Software Error has Occurred	Cycle system power. If the error persists, use GP 9 to reload system software.
09-584-00	Please wait... Adjustments are in progress.	Xerographic adjustment in progress.	Wait until the system recovers. If the error persists, cycle system power. If necessary, review fault code history to identify failed component.
09-588-00	The Toner is empty. Replace NOW.	The Toner Cartridge is empty.	Replace the Toner Cartridge. If the error persists, perform 93-425-00, 93-912-00 K Toner Cartridge Life Near End.

Table 8 Chain 09 Status codes

Code	UI Message	Reason for Message	Reference / Action
09-594-00	Reorder SMart Kit Drum Cartridge but DO NOT replace until prompted.	SMart Kit Drum Cartridge state is near end of life.	Cycle system power. If the error persists, perform 91-913-00 K Drum Cartridge Dead Stop Error
09-639-00	Fuser is missing or misinstalled.	Fuser Missing	Fuser missing or not installed correctly. User intervention needed to install or lock Fuser. If the error persists, perform 10-902-00 Fuser Missing
09-661-00	Confirm if Fuser was replaced.	Fuser cover confirmation status	Fuser replaced. User intervention is required at the local user interface to confirm the replacement of the Fuser.
09-663-00	Confirm if Bias Transfer Roll was replaced.	Bias Transfer Roll replacement yes/no status	Confirm replacment at the Control Panel.

Table 9 Chain 10 Status codes

Code	UI Message	Reason for Message	Reference / Action
10-505-00	The Fuser is warming up. Printing may be delayed.	The Fuser is warming up. Printing may be delayed	Cycle system power. If the error persists, perform 10-311-00 to 10-376-00 Fuser Thermal Error
10-523-00	Maintenance Kit needs replacement. Replace SOON.	Maintenance Kit (Fuser/BTR) at end of life	Replace the Maintenance Kit. If the error persists, perform 10-420-00, 10-421-00 Fuser Near End of Life
10-524-00	Reorder Maintenance Kit but Do NOT replace until prompted.	Maintenance Kit (Fuser/BTR) near end of life	Check Maintenance Kit life count. If the error persists, perform 10-420-00, 10-421-00 Fuser Near End of Life
10-527-00	Fuser System error. Call for assistance.	Fuser component/sensor fault	Cycle system power. If the error persists, perform 10-311-00 to 10-376-00 Fuser Thermal Error

Table 10 Chain 14 Status codes

Code	UI Message	Reason for Message	Reference / Action
14-517-00	Scanner fault. Power off then on and notify system administrator	Scanner fault.	Cycle system power. If the error persists, perform 62-311-00 to 62-389-00 or review fault code history to identify failed component.

Table 11 Chain 15 Status codes

Code	UI Message	Reason for Message	Reference / Action
15-571-00	Unauthorized banknote image reproduction not supported.	Banknote detection system faulted.	Cycle system power. If the error persists, perform 62-790-00 PrelPS XFail

Table 12 Chain 16 Status codes

Code	UI Message	Reason for Message	Reference / Action
16-501-00	Network Services with Job Based Accounting not available. Notify your System Administrator.	Job based accounting not enough DC memory.	Cycle system power. If the error persists, perform 16-930-19 to 16-939-19 Other Network Faults 17
16-502-00	The network controller is about to be reset.	Network Controller reset is about to occur	Cleared when the network controller reset is initiated.
16-503-00	System Error. Power Off then On and notify system administrator.	Incomplete System Information.	Cycle system power.
16-504-00	Some Network Services involving DDNS are not available. Notify your System Administrator.	Generic Fault frame with DDNS disabled	The DDNS address resolution process has failed. Cycle system power. If the error persists, check the DDNS server's network connection.
16-505-00	Some network services involving scan to E-mail are not available. Notify system administrator.	Insufficient memory for E-mail	Cycle system power. If the error persists, check the network connections
16-506-00	Your administrator is reconfiguring the system. Services will not be available.	Your administrator is reconfiguring the system	The system administrator is saving the machine configuration to a remote station.
16-507-00	Some network services involving SLP are not available. Notify your system administrator.	SLP process stopped. Some network controller services are not available	Cycle system power.
16-508-00	Autonet functions are not available. Notify your system administrator.	Autonet is not available	Cycle system power. Printing can continue if other network protocols are used
16-509-00	Some network services involving Internet Fax are not available. Notify system administrator.	Insufficient memory for internet Fax	Cycle system power. Printing can continue if other network protocols are used

Table 12 Chain 16 Status codes

Code	UI Message	Reason for Message	Reference / Action
16-510-00	Network services involving scan to E-mail are not available. Notify system administrator.	Scan to E-mail process failed	Cycle system power. If the problem persists check network connections
16-511-00	Network services related to Internet Fax are not available. Notify system administrator.	Internet Fax process failed	Cycle system power. If the problem persists check network connections
16-512-00	Some Network Services involving USB are not available. Notify your System Administrator.	USB Process Death	Cycle system power. If the problem persists check USB configuration.
16-513-00	Some network services involving SSDP are not available. Notify your system administrator.	Simple service discovery protocol (SSDP) failed.	Cycle system power.
16-514-00	Network services involving scan to E-mail are not available. Notify system administrator	Post office protocol (POP3) (for inbound IFAX messages) process failed	Cycle system power.
16-517-00	Network services involving scan to E-mail are not available. Notify system administrator	SMTP process failed	Cycle system power.
16-518-00	Network services using WS edge client are not available. Notify your system administrator	Web services edge client interface does not work	Cycle system power. If the error persists, check network connections.
16-519-00	Network services using WS edge client are not available. Notify your system administrator	Web services client controller does not work	Cycle system power. If the error persists, check network connections.
16-520-00	Network services using WS edge client are not available. Please notify the system administrator	Web services server controller interface does not work.	Cycle system power. If the error persists, check network connections.
16-521-00	Some network services involving CPI are not available. Notify your system administrator	The network controller's CPI service process has stopped	Cycle system power. If the error persists, perform 16-800-09 to 16-809-47 Other Network Faults 5
16-522-00	Some network services involving job log are not available. Notify system administrator	The network controller's job log service process has stopped	Cycle system power. If the error persists, perform 16-800-09 to 16-809-47 Other Network Faults 5

Table 12 Chain 16 Status codes

Code	UI Message	Reason for Message	Reference / Action
16-523-00	Some network services with job tracker are not available. Notify your system administrator	The network controller's job tracker service process has stopped	Cycle system power. If the error persists, perform 16-800-09 to 16-809-47 Other Network Faults 5
16-524-00	Some network services with Kerberos are not available. Notify your system administrator	The network controller's Kerberos service process has stopped	Cycle system power. If the error persists, perform 16-800-09 to 16-809-47 Other Network Faults 5
16-525-00	Scan to distribution services are not available. Notify your system administrator	The network controller's scan to distribution service process has stopped	Cycle system power. If the error persists, perform 16-810-00 to 16-819-47 Other Network Faults 6
16-526-00	Some network services involving SMB are not available. Notify your system administrator	The network controller's SMB service process has stopped.	Cycle system power. If the error persists, perform 16-810-00 to 16-819-47 Other Network Faults 6
16-527-00	Some network services involving TCP/IP are not available. Notify your system administrator	The network controller's TCP/IP service process has stopped.	Cycle system power. If the error persists, perform 16-810-00 to 16-819-47 Other Network Faults 6
16-528-00	Network services using WS scan temp are not available. Notify your system administrator	The network controller's WS scan temp service process has stopped.	Cycle system power. If the error persists, perform 16-810-00 to 16-819-47 Other Network Faults 6
16-529-00	Network services with Scan compressor are not available. Notify your system administrator	The network controller's Scan compressor service process has stopped.	Cycle system power. If the error persists, perform 16-810-00 to 16-819-47 Other Network Faults 6
16-531-00	System Error. Power Off then On and Notify System Administrator.	Incomplete System Information	Cycle system power.
16-533-00	Service limit exceeded. New services will not be available until some services are removed	Controller software service limit exceeded	Remove some existing services to enable new services to be added. Machine services are available but may be degraded
16-535-00	Immediate job overwrite failed. Perform an on demand overwrite immediately	Immediate job overwrite failed	Cycle system power. If the error persists, perform 16-710-00 to 16-750-11 Unable To Create Client Handle
16-536-00	Network controller error. Some network services not available. Notify system administrator.	The XSA service is unavailable. Network controller error	Cycle system power. If the error persists, perform 16-674-00 to 16-709-00 XSA Database Error

Table 12 Chain 16 Status codes

Code	UI Message	Reason for Message	Reference / Action
16-540-00	Ensure the USB Wireless Network Interface is properly connected.	USB Wireless Network not connected.	Ensure cables are properly connected.
16-544-00	Network cable unplugged	An Ethernet cable is unplugged	Ensure cables are properly connected
16-546-00	System Error. Power Off then On and notify system administrator.	Incomplete System Information. Logon Service Data is corrupt.	Cycle system power.
16-547-00	System Error. Power Off then On and notify system administrator.	Incomplete System Information.SR defaults unable to load.	Cycle system power.
16-548-00	System Error. Power Off then On and notify system administrator.	Incomplete System Information. SR database error.	Cycle system power.
16-550-00	Device entering SW upgrade mode. ALL jobs will be cancelled.	Device entering SW upgrade mode - all jobs will be canceled.	The Device entered a software upgrade mode (all jobs will be deleted). No user intervention is required. Device services are unavailable until the software upgrade process has completed.
16-551-00	Accounting out of memory. Notify your system administrator	Network controller - accounting log is full or a hard disk full state exists	Accounting administrator needs to retrieve accounting data log from the system
16-552-00	Software option codes do not match.	Software Option codes do not match.	Cycle system power.
16-553-00	Additional memory is required to support scan to file. Notify your system administrator	Scan-to File memory shortage	Cycle system power. Hardware must be added or replaced.
16-554-00	Workflow scanning hardware must be added or replaced. Notify your system administrator.	Hardware must be added or replaced.	Cycle system power. Hardware must be added or replaced.
16-555-00	Insufficient memory for Fax job. Notify your system administrator.	LAN Fax memory shortage	Additional memory required to support Fax. The Fax service is not available
16-556-00	802.1X authentication failed, the device will remain offline until resolved. Please contact the system administrator.	Ensure 802.1X settings on the printer match the 802.1X network authentication settings.	Check printer settings to see if they match server settings. Cycle system power. If the error persists, perform 16-780-00 to 16-789-47 Other Network Faults 3

Table 12 Chain 16 Status codes

Code	UI Message	Reason for Message	Reference / Action
16-557-00	Network services using DC platform recovery not available. Notify system administrator	DC Platform Recovery Failed	Cycle system power. If the error persists, review fault code history to identify failed component.
16-558-00	Network services using DC platform recovery not available. Notify system administrator	Network controller DC communications failed	Cycle system power. If the error persists, review fault code history to identify failed component.
16-559-00	Network services using BOOTP initialization not available. Notify system administrator	Network controller BOOTP initialization failure	Check the BOOTP Server and its network connection. If error persists, cycle system power.
16-560-00	Some network services are not available due to a process error. Notify system administrator.	Some processes on the network controller have failed	Cycle system power. If the error persists, perform 16-770-09 to 16-779-95 Other Network Faults 2
16-561-00	Scan to file not available. Power off then on and notify system administrator	Network controller - scan to file processes have failed	Cycle system power. If the error persists, perform 16-759-46 to 16-760-46 Fail to Enable Process
16-562-00	Some network services involving LPD are not available. Notify your system administrator	Network controller - the line printer daemon (LPD) process has failed	Cycle system power. If the error persists, perform 16-760-47 to 16-761-46 File Error
16-563-00	Some network services involving Novell are not available. Notify your system administrator	Network controller - the Novell netware connectivity process has failed	Cycle system power. If the error persists, perform 16-761-47 to 16-769-95 Other Network Faults 1
16-564-00	Some network services involving NetBios are not available. Notify system administrator	Network controller - the NetBIOS connectivity process has failed	Cycle system power. If the error persists, perform 16-761-47 to 16-769-95 Other Network Faults 1
16-565-00	Network services involving Apple Talk are not available. Notify your system administrator	Apple Talk printing error. Printing can continue using other submission methods	Cycle system power. If the error persists, perform 16-761-47 to 16-769-95 Other Network Faults 1
16-567-00	Some network services involving PostScript are not available. Notify your system administrator	Network controller - a PostScript interpreter error has occurred, causing the process to fail	Cycle system power. If the error persists, perform 16-761-47 to 16-769-95 Other Network Faults 1
16-568-00	Some network services involving PCL are not available. Notify your system administrator	Network controller - a PCL interpreter error has occurred, causing the process to fail	Cycle system power. If the error persists, perform 16-761-47 to 16-769-95 Other Network Faults 1

Table 12 Chain 16 Status codes

Code	UI Message	Reason for Message	Reference / Action
16-569-00	Network services involving a parallel port are not available. Notify system administrator	Network controller - parallel ports are not available	Cycle system power. If the error persists, perform 16-761-47 to 16-769-95 Other Network Faults 1
16-570-00	Some network services involving HTTP are not available. Notify your system administrator	Network controller - an HTTP interpreter error has occurred, causing the process to fail	Cycle system power. If the error persists, perform 16-761-47 to 16-769-95 Other Network Faults 1
16-571-00	Network printing disabled. Notify your system administrator	Network controller - print service has failed	Cycle system power. If the error persists, perform 16-770-09 to 16-779-95 Other Network Faults 2
16-572-00	Network printing disabled. Notify your system administrator	Network controller - print service has failed	Cycle system power. If the error persists, perform 16-770-09 to 16-779-95 Other Network Faults 2
16-573-00	Network printing disabled. Notify your system administrator.	Network controller - ESS print service has failed	Cycle system power. If the error persists, perform 16-770-09 to 16-779-95 Other Network Faults 2
16-574-00	Job queue error. Power off then on and notify system administrator	ESS queue utility has failed. Only a partial list is available for display at this time	Cycle system power. If the error persists, perform 16-770-09 to 16-779-95 Other Network Faults 2
16-575-00	The network controller connection is about to be reset	The network controller ESS registration service process has stopped	Cycle system power. If the error persists, perform 16-160-09 NC Registration Service Process Death
16-576-00	Network controller connection is about to be reset	The network controller ESS event notification service process has stopped	Cycle system power. If the error persists, perform 16-161-09 to 16-164-09 Cannot Send Reg Event / List Access Failure
16-577-00	Network controller connection is about to be reset	The network controller ESS platform manager service process has stopped	Cycle system power. If the error persists, perform 16-161-09 to 16-164-09 Cannot Send Reg Event / List Access Failure
16-578-00	Incomplete system information. Power off then on and notify system administrator	The network controller ESS fault log service process has stopped	Cycle system power. If the error persists, perform 16-770-09 to 16-779-95 Other Network Faults 2
16-579-00	Job status not available. Power off then on and notify system administrator	The network controller ESS completed job log service has stopped	Cycle system power. If the error persists, perform 16-770-09 to 16-779-95 Other Network Faults 2

Table 12 Chain 16 Status codes

Code	UI Message	Reason for Message	Reference / Action
16-580-00	Incomplete system information. Power off then on and notify system administrator	The network controller ESS configuration utility process has stopped	Cycle system power. If the error persists, perform 16-770-09 to 16-779-95 Other Network Faults 2
16-581-00	Some network diagnostic services are not available. Notify your system administrator	The network controller ESS diagnostic service process has stopped	Cycle system power. If the error persists, perform 16-770-09 to 16-779-95 Other Network Faults 2
16-582-00	Some network authentication services unavailable. Notify your system administrator	The network controller ESS authentication SPI process has stopped	Cycle system power. If the error persists, perform 16-780-00 to 16-789-47 Other Network Faults 3
16-583-00	Incomplete system information. Power off then on and notify system administrator	The network controller ESS counters utility process has stopped	Cycle system power. Printing and scanning can continue.
16-584-00	Network controller connection is about to be reset	The network controller document manager agent process has stopped	Cycle system power. If the error persists, perform 16-161-09 to 16-164-09 Cannot Send Reg Event / List Access Failure
16-585-00	Incomplete system information. Power off then on and notify system administrator	The network controller ESS configuration synchronization process has stopped	Cycle system power. If the error persists, perform 16-780-00 to 16-789-47 Other Network Faults 3
16-586-00	Incomplete system information. Power off then on and notify system administrator	The network controller agent process has stopped	Cycle system power. If the error persists, perform 16-780-00 to 16-789-47 Other Network Faults 3
16-589-00	Network services involving a serial port are not available. Notify system administrator.	The network controller serial port connectivity has failed	Cycle system power. If the error persists, perform 16-780-00 to 16-789-47 Other Network Faults 3
16-590-00	Network connectivity configuration server not available. Notify your system administrator	The network controller CCS process has failed	Cycle system power. If the error persists, perform 16-780-00 to 16-789-47 Other Network Faults 3
16-591-00	Some network services involving Ethernet are not available. Notify system administrator.	Network controller Ethernet process has failed	Cycle system power. If the error persists, perform 16-800-09 to 16-809-47 Other Network Faults 5
16-593-00	Some network services involving DHCP are not available. Notify your system administrator.	Network controller - DHCP address resolution has failed	Cycle system power. If the error persists, perform 16-800-09 to 16-809-47 Other Network Faults 5

Table 12 Chain 16 Status codes

Code	UI Message	Reason for Message	Reference / Action
16-594-00	Some network services involving RARP are not available. Notify your system administrator.	Network controller - RARP address resolution has failed	Cycle system power. If the error persists, perform 16-800-09 to 16-809-47 Other Network Faults 5
16-595-00	LAN Fax service error. Power off then on and notify system administrator	The network controller LAN Fax service has failed	Cycle system power. If the error persists, perform 16-790-09 to 16-799-47 Other Network Faults 4
16-596-00	Some network accounting services are not available. Notify your system administrator.	Some network controller services are not available	Cycle system power. If the error persists, perform 16-790-09 to 16-799-47 Other Network Faults 4
16-597-00	Some network services involving TIFF are not available. Notify your system administrator.	The network controller TIFF interpreter has failed	Cycle system power. If the error persists, perform 16-790-09 to 16-799-47 Other Network Faults 4
16-598-00	Some network services involving TCP/IP are not available. Notify your system administrator.	Network controller - TCP/IP address is already in use on the network	Cycle system power. If the error persists, perform 16-770-09 to 16-779-95 Other Network Faults 2
16-599-00	Network services with Port 9100 process are not available. Notify system administrator	Raw TCP/IP printing (port 9100) process has failed	Cycle system power. If the error persists, perform 16-790-09 to 16-799-47 Other Network Faults 4

Table 13 Chain 17 Status codes

Code	UI Message	Reason for Message	Reference / Action
17-510-00	Duplicate IPv6 address detected. Reconfigure with a unique address	Duplicate IPv6 address detected	Reconfigure with a unique address. Cycle system power. Copy and Fax services (if installed) can continue
17-512-00	DHCPv6 services are not available. Notify your system administrator.	DHCPv6 Failure status	Cycle system power. Printing can continue with other submission methods.
17-513-00	Duplicate IPv4 address detected. Reconfigure with a unique address	Duplicate IPv4 address detected.	Cycle system power.
17-514-00	The machine is not available. Accounting communication failure	External accounting device communication failure	Administrator intervention required to check the connection to the external accounting device.

Table 13 Chain 17 Status codes

Code	UI Message	Reason for Message	Reference / Action
17-551-00	Server Fax service cannot register. Power off then on and notify system administrator	Server Fax service cannot register	Cycle system power. If the error persists, perform 16-980-00 to 16-989-35 Other Network Faults 22
17-552-00	Reprint Saved Jobs Service cannot Register. Power Off then On. Notify System Administrator.	Reprint Saved Jobs Service cannot Register	Cycle system power. If the error persists, perform 16-752-00 to 16-752-47 Invalid File Details
17-553-00	Internet Fax service cannot register. Power off then on and notify system administrator	Internet Fax service cannot register	Cycle system power. If the error persists, perform 16-950-19 to 16-959-19 Other Network Faults 19
17-554-00	E-mail service cannot register. Power off then on and notify system administrator	Email Service cannot Register.	Cycle system power. If the error persists, perform 16-950-19 to 16-959-19 Other Network Faults 19
17-556-00	The server Fax service cannot un-register. Notify your system administrator	Server Fax service cannot un-register	Cycle system power. If the error persists, perform 16-980-00 to 16-989-35 Other Network Faults 22
17-557-00	The internet Fax service cannot un-register. Notify your system administrator	Internet Fax service cannot un-register	Cycle system power. If the error persists, perform 16-950-19 to 16-959-19 Other Network Faults 19
17-558-00	The E-mail service cannot un-register. Notify your system administrator	E-mail service cannot un-register	Cycle system power. If the error persists, perform 16-950-19 to 16-959-19 Other Network Faults 19
17-559-00	Workflow scanning service cannot register. Power off then on and notify system administrator	Network scanning service cannot register.	Cycle system power. If the error persists, perform 16-980-00 to 16-989-35 Other Network Faults 22
17-560-00	The workflow scanning service cannot un-register. Notify your system administrator	Network scanning service cannot un-register.	Cycle system power. If the error persists, perform 16-980-00 to 16-989-35 Other Network Faults 22
17-561-00	The reprint saved jobs service cannot un-register. Notify your system administrator	Reprint saved jobs service cannot un-register.	Cycle system power. If the error persists, perform 16-752-66 to 16-753-28 Scan to FAX Registration Error
17-562-00	No communications with Xerox SMart eSolutions server. Contact system administrator	Registration with edge server fails	User intervention is required to review SMart eSolutions settings. Cycle system power. If the error persists, perform 16-891-00, 16-892-00 Edge Server Error

Table 13 Chain 17 Status codes

Code	UI Message	Reason for Message	Reference / Action
17-563-00	No communications with Xerox SMart eSolutions server. Contact system administrator	Communication with edge server fails	User intervention is required to review SMart eSolutions settings. Cycle system power. If the error persists, perform 16-891-00, 16-892-00 Edge Server Error
17-565-00	Extensible services are not responding. Power machine off then on	EIP service not responding	Cycle system power.
17-570-00	No message	Communication with NNTP server failed	User intervention is required to verify network time protocol server settings, operability and machine time.
17-580-00	Please wait... disk encryption operation in progress.	Disk encryption is in progress	No service action required, please wait for encryption to finish.
17-590-00	Image overwrite is in progress... the machine is offline.	Image overwrite (ODIO) is in progress	No service action required, please wait for the overwrite to finish.
17-591-00	On Demand Overwrite Failed. Perform an On Demand Overwrite immediately.	HDD or FAX On Demand Overwrite Failed.	Cycle system power. If the error persists, perform 16-710-00 to 16-750-11 Unable To Create Client Handle or 20-710-00, 20-711-00 Fax Card Overwrite Errors as appropriate.

Table 14 Chain 19 Status codes

Code	UI Message	Reason for Message	Reference / Action
19-502-00	Please wait, freeing memory	Out of memory resources. The machine has run out of image processing memory for the current job	No user intervention required, please wait, printing will resume after memory is freed. Other machine services are unaffected. If the error persists, perform 19-401-00, 19-402-00 Out of Memory
19-505-00	Some jobs may have been deleted	Compressor DVMA time-out. Current job has been deleted	Confirm the UI message and re-scan the job. If the error persists, perform the 19-403-00 Out of Memory - Job in EPC

Table 14 Chain 19 Status codes

Code	UI Message	Reason for Message	Reference / Action
19-506-00	Immediate job overwrite failed. Perform an on demand overwrite immediately	Immediate job overwrite failed	Administrator intervention is required to perform an on demand image overwrite immediately. Printing can continue. Other machine services are unaffected.
19-507-00	On Demand Overwrite Failed. Perform an On Demand Overwrite immediately.	HDD or FAX On Demand Overwrite Failed.	Cycle system power. If the error persists, perform 16-710-00 to 16-750-11 Unable To Create Client Handle or 20-710-00, 20-711-00 Fax Card Overwrite Errors as appropriate.
19-510-00	Please wait... the system is attempting to recover	System is attempting to recover. Image disk error	No service action required. Printing and other machine services are unaffected
19-511-00	Image disk is offline. Job(s) may take longer than normal. Notify system administrator	Image disk unavailable. Performance is degraded. Service is required	Perform the 19-300-00 to 19-310-00 Image Disk (HDD) Failure
19-512-00	Image disk offline. Power off then on and notify system administrator	The image disk must be serviced. Power off/power on will temporarily alleviate the problem.	Perform the 19-300-00 to 19-310-00 Image Disk (HDD) Failure.
19-513-00	Please wait... The image disk is full	The image disk is full	Print jobs may be delayed. No service action required. The system is attempting to recover. Printing and other machine services are available
19-514-00	All incomplete jobs have been deleted	Video job integrity fault detected	If the error persists, perform the 19-409-00 Video Integrity Fault
19-550-00	Configuration mismatch	The controller cannot access the EPC memory or the image disk	Cycle system power. Install a new hard disk drive, PL 18.1 Item 97. Install a new ESS Board, PL 18.1 Item 98.

Table 15 Chain 20 Status codes

Codes	UI Message	Reason for Message	Reference / Action
20-545-00	Fax job could not be sent at this time, please try again	A Fax job could not be sent	Fax job could not be sent, retry. Printing and other machine services are available
20-546-00	Fax memory is low. Contact your system administrator	Not enough memory to use Fax service	Cycle system power. If the error persists, perform 20-323-00, 20-324-00 Fax System Memory is Low
20-547-00	Fax memory is low. Contact your system administrator	Fax memory is low	User intervention is required to delete unnecessary mailbox files or Fax jobs stored for polling. Cycle system power. If the error persists, perform 20-323-00, 20-324-00 Fax System Memory is Low
20-550-00	Fax line 2 is unavailable. Notify your system administrator	Extended Fax card failure detected	Cycle system power. Fax service can continue from line 1. Printing and other machine services are available
20-556-00	Fax memory error. Power off then on and notify system administrator	Fax service error. Reset Fax service	Cycle system power. If the error persists, perform 20-331-00 to 20-341-00 Fax Network Line 1 Fault
20-558-00	Fax memory error. Power off then on and notify system administrator	Fax memory error	Cycle system power. If the error persists, perform 20-322-00 NV Device Not Fitted to Basic Fax Card
20-559-00	Fax memory error. Power off then on and notify system administrator	Fax service error	Cycle system power. If the error persists, perform 20-320-00 Fax Fault Not Cleared by Card Reset
20-562-00	Fax line 1 is unavailable. Check line connection or notify your system administrator	No communication on Fax line 1	Cycle system power. If the error persists, perform 20-331-00 to 20-341-00 Fax Network Line 1 Fault
20-563-00	Fax line 2 is unavailable. Check line connection or notify your system administrator	No communication on Fax line 2	Cycle system power. If the error persists, perform 20-331-00 to 20-341-00 Fax Network Line 1 Fault
20-565-00	Fax job limit has been reached. Power off then on and notify system administrator	All jobs IDs allocated cannot create any more	Cycle system power. Fax and LAN Fax are disabled
20-570-00	Fax memory error. Power off then on and notify system administrator	Fax service error	Cycle system power. If the error persists, perform 20-342-00 Error Accessing File on a NV Device

Table 15 Chain 20 Status codes

Codes	UI Message	Reason for Message	Reference / Action
20-544-00	Please wait... The Fax service is initializing	The Fax service is initializing	The Fax service is re-starting. No user intervention is required. Printing and other machine services are available

Table 15 Chain 20 Status codes

Codes	UI Message	Reason for Message	Reference / Action
20-571-00	Fax memory error. Power off then on and notify system administrator	Fax service error	Cycle system power. If the error persists, perform 20-331-00 to 20-341-00 Fax Network Line 1 Fault
20-572-00	Fax line 2 is unavailable. Call for assistance	Fax service error. Fax line 2 is unavailable	Cycle system power. If the error persists, perform 20-331-00 to 20-341-00 Fax Network Line 1 Fault
20-580-00	Fax service is unavailable. Turn machine off then on	NVM values supplied by the Fax are invalid. Fax NVM data error	Cycle system power. If the error persists, perform 20-302-00 to 20-305-00 Fax Card HW or SW Error
20-595-00	Fax line 1 is unavailable. Call for assistance.	Fax service Error. Fax line 1 is unavailable	Cycle system power. If the error persists, perform 20-345-00 FaxPort1 Modem Failure

Table 16 Chain 22 Status codes

Codes	UI Message	Reason for Message	Reference / Action
22-501-04	Please wait... The system is attempting to recover.	System is in recovery	Wait for the system to recover. If the error persists, perform 22-310-04 to 22-318-04 Other Network Faults 25
22-502-04	No message	An active message has been produced.	Select the Current Messages button in the Machine Status for more information.
22-503-04	All incomplete jobs have been deleted.	System Error - Jobs have been lost.	Resubmit job. If the error persists, perform 22-310-04 to 22-318-04 Other Network Faults 25
22-503-05	The number of originals was less than the number originally scanned	Not enough originals detected in the DADF during DADF fault recovery.	Re-sort and reload all originals. If the error persists, perform 05-940-00 No Original Fail
22-504-04	No tray is configured with the required paper size	No paper tray is configured to run the stock size required for this job	Job must be deleted. Paper tray must be configured to match the job. If the problem persists, perform the 22-310-04 to 22-318-04 Other Network Faults 25
22-504-05	Invalid original size detected. It will be treated as the next largest standard size	Invalid mixed size original pair detected	Make sure the originals are not creased or folded

Table 16 Chain 22 Status codes

Codes	UI Message	Reason for Message	Reference / Action
22-504-16	Machine is in a non customer mode.	Non customer mode. Auto configuration is disabled. Wait for machine to exit Diagnostics mode. The machine is unavailable	Use the attached Non-Customer Mode Recovery procedure to recover.
22-505-00	Remove documents from the document feeder input tray or close the document feeder.	Documents sensed in the DADH tray during IIT standby and document handler cover is open.	To scan from the document glass, remove documents in the document feeder input tray. To use the document feeder to scan your documents, lower the document feeder.
22-505-05	Start accepted. Job will begin when the system is ready.	fax and network scan	Scanning delayed temporarily. Job begins when the system is ready.
22-505-17	Machine is in a non-customer mode	Machine is in a non-customer mode	Use the attached procedure to recover.
22-506-17	Auto configuration is disabled	Machine is in a non-customer mode	Use the attached procedure to recover.
22-508-04	Scanning will be delayed	Scan start up delayed whilst awaiting resources	Job will begin when system is ready. If the error persists, perform the 22-330-01 to 22-332-00 Queue Timed Out
22-511-04	Paper required for current job is not available	Media required for current marking job is not loaded	Load the correct paper to complete the held job or cancel the held job. Other machine services are unaffected.
22-512-04	Auto Paper Select is not available.	All trays have been specified by the SA/KO to be direct select trays.	System administrator intervention is required to enable at least one tray for auto selection.
22-513-04	One or more queued jobs need resources.	One or more queued jobs in the system is being held.	Queued job needs resources. User intervention is required to supply resources required for one or more queued jobs; jobs will be held until resources are available.
22-515-04	One or more queued jobs need resources.	One or more queued jobs in the system is being held.	Queued job needs resources. User intervention is required to supply resources required for one or more queued jobs; jobs will be held until resources are available.



Table 16 Chain 22 Status codes

Codes	UI Message	Reason for Message	Reference / Action
22-552-00	Option Install error. Please wait...The system is attempting to recover.	Option Install Error.	Wait for the system to recover. If the error persists, perform 22-350-01, 22-350-02 Software Detects Non-Valid Xerox SOK
22-553-00	Please wait... One or more options are being installed.	Options are being installed.	Wait for the system to recover. If the error persists, perform 22-351-01 to 22-351-03 SOK Write Failure
22-554-00	Please wait... One or more options are being removed.	Options are being removed.	Wait for the system to recover. If the error persists, perform 22-351-01 to 22-351-03 SOK Write Failure
22-555-00	Option Install error. If problem persists call for assistance.	Option Install Error.	Cycle system power. If the error persists, perform 22-351-01 to 22-351-03 SOK Write Failure
22-556-00	Option Removal error. If problem persists call for assistance.	Option Removal Error.	Cycle system power. If the error persists, perform 22-351-01 to 22-351-03 SOK Write Failure
22-557-00	Configuration parameter error.	Serial number sync failure	Cycle system power. Use dC132 to check the serial number. Use dC131 to check printer configuration. If the error persists, perform 22-352-00, 22-352-01 Serial Number Lost/Missing
22-558-00	Your software is not the latest version. Do you want to upgrade now?	Power On Upgrade Available	Accept the upgrade. If the error persists, use GP 9 to force the upgrade.
22-561-00	Network Controller error. Contact System Administrator.	Raised when printer speed, Geo Region or CRU Ordering has changed via SIM card.	Cycle system power. If the error persists, perform 03-399-00 SIM Card Data Cannot be Processed
22-562-00	Network Controller error. Contact System Administrator.	Network Controller Error	Cycle system power. If the error persists, perform 22-370-00 Unable to Communicate with XSA Database
22-563-00	System Error. Power Off then On and notify system administrator.	Incomplete System Information. SR Dead - declared by ESS reg service.	Cycle system power.
22-564-00	System Error. Power Off then On and notify system administrator.	Incomplete System Information. Acct Service Data is corrupt.	Cycle system power.

Table 16 Chain 22 Status codes

Codes	UI Message	Reason for Message	Reference / Action
22-566-00	The Fax Service cannot Register. Notify your System Administrator.	Fax service cannot register	Cycle system power. If the error persists, perform 22-371-00, 22-372-00 Fax Application Registration Error
22-567-00	The Fax Service cannot Un-Register. Notify your System Administrator.	Fax service cannot un-register	Cycle system power. If the error persists, perform 22-371-00, 22-372-00 Fax Application Registration Error
22-568-00	No message	Status requiring POPO detected & Auto-Reset Count less than 2	Status codes requiring a POPO are defined in the Auto-Restart column. NVM 616-216 counts restart attempts the system will automatically try before engaging the user. NOTE: This status should never be added to the auto-restart list
22-580-00	Register for your Supplies Plan.	Service Plan registration alert.	Supplies Plan registration required. User intervention is required to enter Supplies Plan code.
22-581-00	The Supplies Plan is unknown. Print services are disabled.	Service Plan is undetermined.	Supplies Plan registration required. User intervention is required to enter Supplies Plan code. Print and Copy services are disabled.
22-582-00	The Supplies Plan expires soon. Contact your System Administrator.	Service Plan registration warning.	Supplies Plan expires soon. Contact your System Administrator to enter Activation Code. Print services are unaffected.
22-583-00	The Supplies Plan expires in {%d} days.	Service Plan registration expiration warning.	Supplies Plan registration expiration warning. Contact System Administrator to enter activation code. Print services are disabled.
22-584-00	The Supplies Plan has expired. Print services are disabled.	Service Plan registration expired.	Supplies Plan has expired. Contact your System Administrator to enter Activation Code. Print services are disabled.

Table 17 Chain 72 to 77 Status codes

Code	UI Message	Reason for Message	Reference / Action
72-215-00	Optional Feeder Configuration Failure.	Feeder Composition Failure	Cycle system power. If the error persists, perform 71-215-00 Tray Feeder Composition Error

Table 17 Chain 72 to 77 Status codes

Code	UI Message	Reason for Message	Reference / Action
77-098-00	Optional Feeder Failure.	Option Feeder Mode Error	Cycle system power. If the error persists, perform 72-098-00 to 74-098-00 Option Feeder Mode
77-216-00	Feeder Motor Failure.	Option Feeder Motor Failure	Cycle system power. If the error persists, perform 73-216-00 Option Feeder Motor3 Error

Table 18 Chain 91 to 95 Status codes

Code	UI Message	Reason for Message	Reference / Action
92-530-00	Paper tray communication fault. Please call for assistance	Cannot communicate with Paper Trays 2-4	Cycle system power. If the error persists, perform 70-099-00 I/F IOTFED Communication
95-100-00	Software Upgrade Failure.	Software Upgrade Failure	An attempted upgrade did not complete successfully. Use GP 9 to upgrade.

OF 4 Convenience Stapler Failure

To identify problems with the convenience stapler.

Procedure

WARNING

Ensure that the electricity to the machine is switched off while performing tasks that do not need electricity. Disconnect the power cord. Electricity can cause death or injury. Moving parts can cause injury.

WARNING

Take care when measuring AC mains (line) voltage. Electricity can cause death or injury.

NOTE: There are no serviceable components in the convenience stapler.

Refer to Figure 1 and check the power lead is correctly connected to the convenience stapler. Check the AC mains (line) voltage at the customer power outlet. **The voltage measured is within the power requirements.**

Y N
If the voltages are incorrect or the wiring of the main supply is defective, inform your technical manager and the customer. Do not attempt to repair or adjust the customer supply.

Install a new convenience stapler, REP 18.2.6.

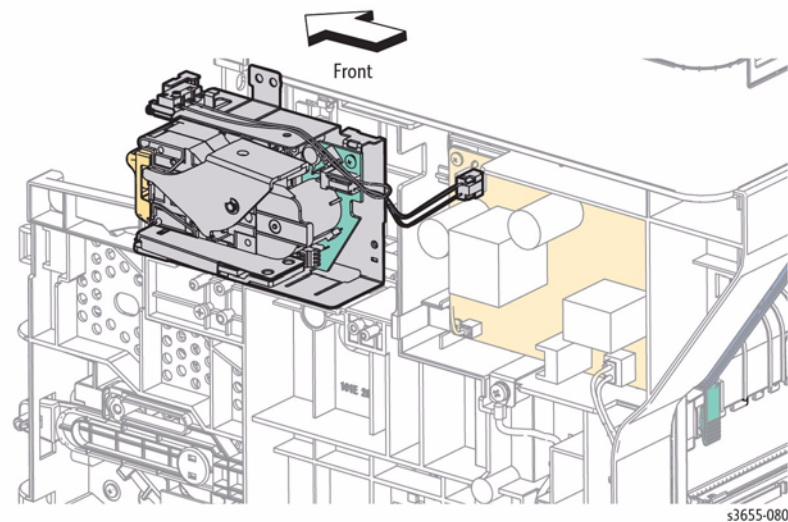

Figure 1 Stapler Assembly

OF 5 Multi-feed Error

To solve several sheet multi-feeds or extra blank sheet output problems.

Initial Actions

WARNING

Ensure that the electricity to the machine is switched off while performing tasks that do not need electricity. Disconnect the power cord. Electricity can cause death or injury. Moving parts can cause injury.

- Check media condition. Do not use incorrectly cut paper, damp paper, paper with rough edges, badly drilled paper, paper with wrapper wax or glue contamination.
- Check media specifications, GP 26.

Procedure

When troubleshooting multi-feeds, use a new ream of paper. If a new ream can not be used, perform the following:

1. Fan the paper.
2. Turn the paper round or turn the paper over.
3. Remove four or five sheets from the top of the stack.

Bypass Tray

Perform the following:

1. Ensure that the customer is not filling the tray above the max fill line.
2. Clean the Pick-up Assembly, PL 13.1 Item 15 with a damp cloth with water.
3. Check that the Retard Roller, PL 13.2 Item 98 is clean, has torque resistance and does not rotate freely.

Tray 1

Check the following:

1. Check the tray side guides.
2. The bottom plate drops down when the tray is pulled out and elevates when pushed in.
 - a. Check the Transport Assembly components, PL 15.2.
 - b. Check the Feed Rolls, PL 9.2 Item 98.
 - c. Check that the friction clutch, PL 9.2 Item 5 in the Retard Roll Assembly has a torque resistance and does not rotate freely.
3. Check the tray for worn, broken or missing components. Replace if necessary, PL 9.2 Item 1.

Optional Trays

Check the following:

1. The bottom plate drops down when the tray is pulled out and elevates when closed.
 - a. Check the Optional Feeder Feed Assembly, PL 11.2.
 - b. Check that the friction clutch, PL 11.3 Item 99 in the Retard Roll Assembly has a torque resistance and does not rotate freely.
2. Check tray for worn, broken or missing components.

OF 6 Power On Self Test (POST)

POST is the Power-On Self Test that runs during the boot process and prior to loading of the operating systems (OS). POST checks basic system functions throughout the printer before passing control onto the operating system.

POST Fault LED Codes

Refer to Figure 1 to locate the row of eight LEDs used to display POST faults. To view the POST LEDs, remove the Left Rear Cover, REP 19.2.2. The LEDs may indicate a hardware problem ahead of the operating system loading and the LEDs can be used to determine the problem with the printer when the Control Panel is not functioning.

Go to [OF 7](#) to check input power.

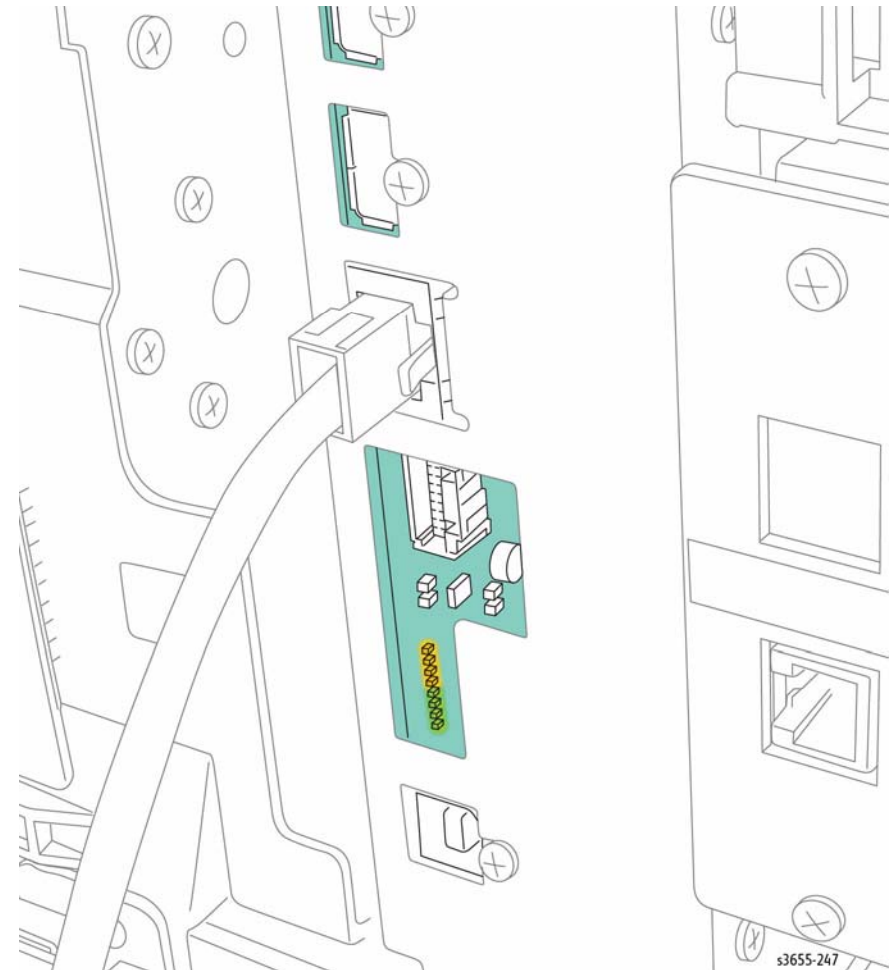

Figure 1 POST LED Location

POST Fault Codes

The following tables list possible POST fault indications.

Table 1 Boot Loader Initialization

LED Value	Boot Loader Status	Component	Error Indication	Fault Code
1 = ON 0 = OFF				
00000000	Initial status of power-on	ESS Board	On	None
00000001	CPU CORE initialization done	ESS Board	On	None
00000010	DDR initialization done	ESS Board	On	None
00000011	Access window configuration done	ESS Board	On	None
00000100	DDR pre-access Wait process done	ESS Board	On	None
00000101	DDR memory check Write done	ESS Board	On	None
00000110	DDR memory check done	ESS Board	On	None
00000111	DDR memory zero clear done	ESS Board	On	None
00001000	Copy to memory of Panbug (Text)	ESS Board	On	None
00001001	Copy to memory of Panbug (Base)	ESS Board	On	None
00001010	Stack pointer configuration done	ESS Board	Flashing	None
00010000	Start hardware initialization process	ESS Board	On	None
00010001	I2C module initialization done	ESS Board	On	None
00010010	Interrupt controller initialization done	ESS Board	On	None
00010011	GIO configuration done	ESS Board	On	None
00010101	MSR register initialization done	ESS Board	On	None
00010110	HID0 register initialization done	ESS Board	On	None
00010111	Debug serial initialization done	ESS Board	On	None
00011001	PCI-Express module initialization done	ESS Board	On	None
00100000	Start software initialization processing	ESS Board	On	None
00100001	Obtain and store MacAddress done	ESS Board	On	None
00100010	Memory domain variable config done	ESS Board	On	None
00100011	Command table initialization done	ESS Board	On	None
00100100	Debug serial interruption enabling done	ESS Board	On	None
00100101	CPU GPIO interruption enabling done	ESS Board	On	None
00100110	Timer interruption enabling done	ESS Board	On	None
00100111	Other interruption enabling done	ESS Board	On	None
00101010	SD Card initialization done	ESS Board	On	None
00110001	JUMP to Panbug Main section	ESS Board	On	None
00110010	Defective/missing EEPROM on ESS	ESS Board	On	016-351
11111111 00000000	Repeat alternate pattern On/Off DDR initialization processing failure	ESS Board	Flashing	None
11110000 00001111	Repeat alternate pattern On/Off Test error of DDR memory Read/Write	RAM	Flashing	None
11000000 00000011	Repeat alternate pattern On/Off Unable to recognize PCI-Express	ESS Board	Flashing	None

Table 2 Boot Loader CPU Off Recovery

LED Value	Boot Loader Status	Component	Error Indication	Fault Code
00110011	DDR pre-access Wait process done	ESS Board	On	None
00110100	Access window configuration done	ESS Board	On	None
00110101	NVRAM Write Protect unlock done	ESS Board	On	None
00110110	Jump to CPU OFF recovery done	ESS Board	On	None
00110111	Reserved	ESS Board	On	None
00111000	Reserved	ESS Board	On	None
00111001	Clear processing of Data Cache done	ESS Board	On	None
00111010	ASIC Cielo initialization done	ESS Board	On	None
10000000 00000001	Repeat alternate pattern On/Off Reserved	ESS Board or RAM	Flashing	None
11111111	Recovery from CPUOFF Mode	ESS Board	On	None

Table 3 SD Card Initialization

LED Value	Boot Loader Status	Component	Error Indication	Fault Code
11010000	Start SD module initialization	RAM or SD Card	Flashing	117-329
11010001	SD module register initialization done	RAM or SD Card	Flashing	117-319
11010010	SD module interrupt configuration done	RAM or SD Card	Flashing	117-319
11010011	SD module clock initialization done	RAM or SD Card	Flashing	117-319
11010100	SD card initialization command 1 done	RAM or SD Card	Flashing	117-321
11010101	SD card clock enabling done	RAM or SD Card	Flashing	117-321
11010110	SD card initialization done	RAM or SD Card	Flashing	117-321
11010111	SD card unlock done	RAM or SD Card	Flashing	117-319
11011000	SD card information obtain done	RAM or SD Card	Flashing	117-319
11011001	SD card bus width configuration done	RAM or SD Card	Flashing	117-319
11011010	SD module initialization done	RAM or SD Card	Flashing	117-319
11011011	Start read processing from SD card	RAM or SD Card	Flashing	117-319
11011100	SD module initial check done	RAM or SD Card	Flashing	117-319

Table 3 SD Card Initialization

LED Value	Boot Loader Status	Component	Error Indication	Fault Code
11011110	Program memory expansion done	RAM or SD Card	Flashing	None
11110000 00001111	Repeat alternate pattern On/Off Extend processing error of Program data	RAM or SD Card	Flashing	117-319

Table 4 Switch Off Recovery

LED Value	Boot Loader Status	Component	Error Indication	Fault Code
00110011	DDR pre-access Wait process done	ESS Board	On	None
00110100	Access window configuration done	ESS Board	On	None
00110101	NVRAM Write Protect unlock done	ESS Board	On	None
00110110	Jump to CPU OFF recovery done	ESS Board	On	None
00110111	Checksum calculation of data done	ESS Board	On	None
00111000	Compare checksum values done	ESS Board	On	None
00111001	CPU GPIO initialization done	ESS Board	On	None
00111010	Debug serial initialization done	ESS Board	On	None
00111011	PCI-Express module initialization done	ESS Board	On	None
00111100	Software initialization done	ESS Board	On	None
11111111	Recovery from Switch OFF Mode	ESS Board	On	None

OF 7 Input Power Check

To verify that input power is correct.

Procedure

WARNING

Ensure that the electricity to the machine is switched off while performing tasks that do not need electricity. Disconnect the power cord. Electricity can cause death or injury. Moving parts can cause injury.

WARNING

Take care when measuring AC mains (line) voltage. Electricity can cause death or injury.

Refer to Wiring Diagram Figure 1. Insure that the Main Switch is at ON and that there is 110 volts on the LVPS at PJ200 between pins 1 & 3.

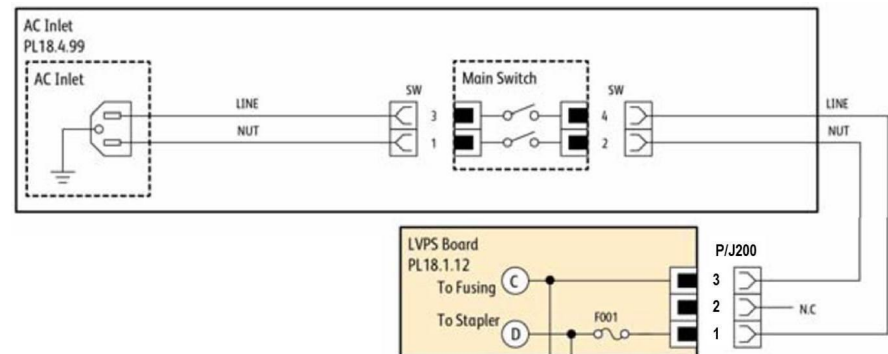

Figure 1

Then check on the LVPS for the presence of the 5 Volts Standby at P211 between pins 1 & 2. Refer to Figure 2. If 5vdc is not present, replace LVPS [PL 18.1 item 12](#).

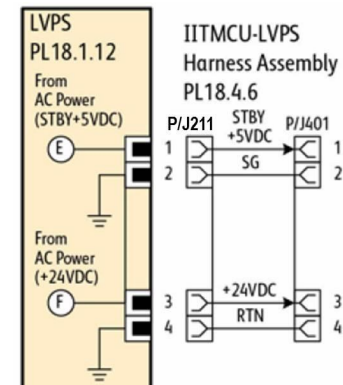

Figure 2

3 Image Quality

IQ1 Image Quality Entry	3-3
IQ2 Deletions (line, band, spots)	3-4
IQ3 Unfused Image	3-5
IQ4 Resolution	3-6
IQ5 Skewed Image	3-6
IQ6 Light or Undertoned Print	3-7
IQ7 Spots	3-8
IQ8 Blank Print	3-9
IQ9 Black Print	3-10
IQ10 Process Streaks	3-11
IQ11 Scan Streaks	3-12
IQ12 Damaged Print	3-13
IQ13 Repeating Defects	3-14
IQ14 Residual Image	3-15
IQ15 Background	3-16
IQ16 Uneven Density	3-17
IQ17 Stains on Print Back	3-18
IQ18 Registration	3-18
IQ19 Curved Vertical Lines	3-19
Test Prints	3-19
IQS 1 Solid Area Density	3-20
IQS 2 Skew	3-20
IQS 3 Registration	3-21
IQS 4 Transparencies	3-21
IQS 5 Image Area	3-22

IQ1 Image Quality Entry

The purpose of this procedure is to establish the source and type of imaging defect. Print-quality defects can be attributed to printer components, consumables, media, internal software, external software applications, and environmental conditions. To successfully troubleshoot print-quality problems, eliminate as many variables as possible. First, recreate the perceived defect using the customer's job or test print. Use approved laser paper from a fresh ream acclimated to room temperature and humidity.

If the print-quality defect is still present after printing on approved media from an unopened ream of paper, investigate software applications being used and environmental conditions. Check the temperature and humidity under which the printer is operating. Compare this to the "Environmental Specifications". Extreme temperature and humidity can adversely affect the printer's xerographic and fusing characteristics.

When analyzing a imaging defect, determine if the defect is repeating or random. Continuous defects in the process direction, such as voids and lines, are the most difficult to diagnose. Check the CRU life counters for end of life conditions. Inspect the visible surfaces of all rollers for obvious defects. If a cursory inspection does not reveal any obvious defects, continue troubleshooting the defect, starting with the list of initial actions.

Initial Actions

Use the following steps to determine which part of the system is at fault.

1. If possible, discuss the defect with the customer to determine if the perceived defect is outside the printer's image specifications.
2. Ensure all connections to the printer are secure.
3. Check the CRU life counts. Replace components at end of life.
4. Make sure the printer is positioned to allow adequate airflow at all vents. Refer to GP 22, Installation Space Requirements.
5. Make sure the printer's interior is clean.
6. Check the tray guides.
7. Use the customer's print job to check defect reoccurrence. If the defect persists, begin to isolate the defect by attempting to identify the component responsible.
8. Check stored tray settings for media size and type.
9. Check image adjustment and print mode settings being used.
10. Check current humidity.
11. Check the paper in use. Try printing on a different media.
12. Check the image problem is not file specific.
13. Print from a different tray to check media transport.
14. Cycle system power.

Defects Associated with Specific Components

To aid with defect diagnosis, listed below are defects associated with specific components.

Laser Unit image defects:

- Black Print
- Vertical white lines
- Curved lines

Transfer Roller image defects:

- Uneven Density
- Background contamination
- Ghosting
- Vertical white lines
- Vertical black line or band
- Stains on the page back

Fuser image defects:

- Ghosting
- Stains on the page back or front
- Poor image adhesion

Drum Cartridge image defects:

- Uneven density
- Background contamination
- Spots, smudges, or smears
- Ghosting
- Vertical white lines
- Vertical black line or band
- Stains on the page front
- Blank prints
- Black prints
- Horizontal Black lines or bands

After determining the defect type and possible source, match the defect with those listed in Table 1. Go to the RAP listed to correct the defect.

Image Defect Definitions

Table 1 lists image defect definitions and the RAP(s) used to correct the problem.

Table 1 Image Defect Definitions

Defect	Definition	Go To
Deletions	There are areas (lines, bands, spots) missing entirely.	IQ2
Unfused Image	Part or all of the image is infused. Refer to the specification.	IQ3
Resolution	At 600 dpi, the two pixel lines and halftone patches cannot be reproduced clearly on the print.	IQ4
Skips and Smears	Skip - Image loss or stretching in horizontal bands. Smear - Image distortion in bands across the process direction that appear blurred or compressed.	IQ2
Spots	There are spots of toner on the page.	IQ7
Skewed Image	Angular image displacement from its intended position.	IQ5
Light Prints	The overall image density is too light.	IQ6
Blank Prints	Prints with no visible image.	IQ8
Black Prints	The print is completely covered with toner with no image.	IQ9
Process Deletions	Areas of the image are extremely light or missing entirely. Defects run vertically in the direction of paper movement.	IQ2

Table 1 Image Defect Definitions

Defect	Definition	Go To
Scan Deletions	Areas of the image are extremely light or missing entirely. Defects run horizontally across the page.	IQ2
Process Streaks	Extraneous dark lines/bands in the process direction.	IQ10
Scan Streaks	Extraneous dark lines/bands in the direction of scan.	IQ11
Damaged Prints	Creases, wrinkles, excessive curl, cuts, folds or embossed marks.	IQ12
Spot Deletions	Solid areas are marked with irregular white areas.	IQ2
Repeating Defects	Recurring marks, spots, lines, or voids.	IQ13
Residual Image	The image from a previous print appears on the current print.	IQ14
Background	Uniform toner contamination in non image areas. See Background specification.	IQ15
Uneven Density	The text/line darkness and solid area density image varies across the print.	IQ16
Registration	Displacement of the image, in the process or scan direction, from its intended position on the print.	IQ18
Curved Vertical Lines	Vertical lines are curved and distorted.	IQ19
Stains on Print Back	Toner appears on the reverse side on single-sided images.	IQ17
Lead Edge Mis-Registration	Lead edge registration is incorrect, creating excessive border on the lead or trail edge	ADJ 8.1

IQ2 Deletions (line, band, spots)

Use this procedure to correct defects that appear as areas of image deletions.

Initial Actions

- Check that the paper supply is dry and meets specifications.
- Inspect the paper path for items, such as staples, paper clips, and paper scraps.
- Check Drum Cartridge installation.
- Clean Drum Cartridge contacts.
- Check the Transfer Roller for contamination or wear.
- Check that rollers and other media path components are clean and unobstructed.
- If vertical lines of deletion appear, clean the Laser Unit window.

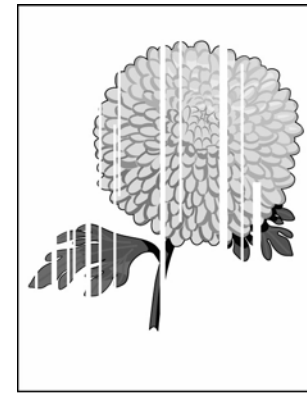

Vertical Blank Lines

Figure 1 Line, band, or spot deletions example

Procedure

WARNING

Switch off the electricity to the machine. Disconnect the power cord from the customer supply while performing tasks that do not need electricity. Electricity can cause death or injury. Moving parts can cause injury.

WARNING

Do not touch the Fuser while it is hot.

Print and inspect a test print for deletions (missing image). There should be no deletions with a diameter larger than 0.5 mm visible on the test prints. **No deletions are visible.**

Y N
Perform SCP 6 Final Actions.

Check the media. **The media is clean, of the approved type, and free of defects.**

Y N
Replace the media with approved media from a freshly opened package.

A

A
Check the media path for dirt, debris, or toner residue. **The media path is clean.**

Y N
Clean the media path.

Replace the Drum Cartridge and reprint the test print. **The image contains spots.**

Y N
Perform SCP 6 Final Actions.

Remove and examine the Transfer Roller for surface contamination or excessive wear. **The Transfer Roller is good.**

Y N
Replace the Transfer Roller, REP 6.1.1.

Check for debris on the Laser Unit window or obstructions between the Laser Unit and Drum Cartridge. **The laser light path is clear.**

Y N
Clear the laser light path of obstructions.

Remove and examine the Fuser for damage or debris on the rollers. **The Fuser rollers are good.**

Y N
Replace the Fuser, REP 7.1.1.

Check connections between the ESS Board and Laser Unit. **The connections are secure.**

Y N
Secure the connections.

Replace the ESS Board, REP 18.1.98.

IQ3 Unfused Image

The printed image is not fully fused to the paper. The image rubs off easily. A cold environment affects the warm-up time, while high humidity has an adverse effect on fusing. Also, media weight and composition affect fusing performance.

Initial Actions

- Check the environment. A location that's too cold or humid reduces fusing performance.
- Inspect the media path for debris, such as staples, paper clips, and paper scraps.
- Verify that the media type is set correctly.

Procedure

WARNING

Switch off the electricity to the machine. Disconnect the power cord from the customer supply while performing tasks that do not need electricity. Electricity can cause death or injury. Moving parts can cause injury.

WARNING

Do not touch the Fuser while it is hot.

Rub the image with a soft cloth or tissue. **The image smears.**

Y N
Perform SCP 6 Final Actions.

Replace the media with new, dry media from an unopened ream. **The image smears.**

Y N
Perform SCP 6 Final Actions.

Check the Fuser lock levers. **The Fuser is locked.**

Y N
Lock the Fuser, cycle system power and test.

Remove and inspect the Fuser, REP 7.1.1. **The Fuser rollers are good.**

Y N
Replace the Fuser, REP 7.1.1.

Check the Fuser electrical connection. **The connector is good.**

Y N
Repair or replace the harness.

Replace the Fuser, REP 7.1.1.

IQ4 Resolution

The two pixel lines and halftone patches cannot be reproduced clearly on the test print.

Procedure

Inspect the three resolution check points on several test prints. Check the image resolution in each of these areas:

- The vertical, horizontal, and diagonal lines should be clear and continuous. The diagonal lines might appear to be narrower than the others.
- The text paragraphs should be roughly equal in density.
- The half-tone patches adjacent to the solid blocks in the corners should be uniform in appearance.

The check points meet specification.

- | | | |
|---|---|---|
| Y | N | |
| | | Replace the following as necessary: |
| | | <ul style="list-style-type: none">• Drum Cartridge, REP 8.1.2• Fuser, REP 7.1.1• Laser Unit, REP 2.1.1• MCU Board REP 18.2.2• ESS Board REP 18.1.98 |

Perform SCP 6 Final Actions.

IQ5 Skewed Image

The image is not parallel to the edge of the print sheet.

Initial Actions

- Check that the paper guides are set correctly.
- Load new, dry paper that meets specifications.
- Check the rollers in the paper path for any obstructions, damage, or debris.

Procedure

Print a test print and measure the difference between dimensions A and B as indicated in. **The difference is more than 1 MM or less for single side or 4 MM front to back on double sided prints.**

- | | | |
|---|---|--|
| Y | N | |
| | | The printer is operating within specification. Perform SCP 6 Final actions |

Check the installation. **The printer is on a level surface.**

- | | | |
|---|---|--|
| Y | N | |
| | | Correct the installation. No more than a 10 mm difference side to side or front to back is required. |

Reload the tray with new, previously unopened media and reprint the test print. **The image is skewed.**

- | | | |
|---|---|--|
| Y | N | |
| | | Instruct the customer on proper media storage and perform SCP 6 Final Actions. |

Print test prints from a different source tray. **The image is skewed.**

- | | | |
|---|---|--|
| Y | N | |
| | | Check the rollers and guides for the affected tray. Clean, repair or replace damaged or worn components. |

Check rollers in the entire paper path.

- Check the registration rollers for contamination, wear, or damage.
- Check whether pinch rollers rotate freely and spring pressure is applied evenly.

Replace these components in order until the error is corrected.

- Registration Clutch, REP 15.2.4
- Transport Assembly, REP 15.1.6
- MCU Board, REP 18.2.2

IQ6 Light or Undertoned Print

The overall image density is too light.

WARNING

Switch off the electricity to the machine. Disconnect the power cord from the customer supply while performing tasks that do not need electricity. Electricity can cause death or injury. Moving parts can cause injury.

WARNING

Do not touch the Fuser while it is hot.

Initial Actions

- Inspect the paper path for items, such as staples, paper clips, and paper scraps.
- Check the Drum Cartridge life counter. If at end of life, replace the Drum Cartridge.
- Check that the Drum Cartridge electrical contact points are clean.
- Ensure that there are no obstructions in the laser light path.
- Ensure that draft mode is turned Off.
- Check for excessive humidity.

Check Altitude Adjustment. Go to Machine Status, Tools tab, Device Settings, General, Altitude Adjustment.

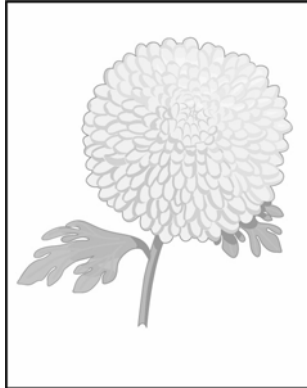

Light or Undertone Print

Figure 1 Light or undertone print example

Procedure

Check media condition. Load new, dry recommended paper, and print a test print. **The image is too light.**

Y N
| Perform SCP 6 Final Actions.

Replace the Drum Cartridge and reprint the test print. **The image is too light.**

Y N
| Perform SCP 6 Final Actions.

A

A

Remove examine the Transfer Roller for surface contamination or excessive wear. **The Transfer Roller is good.**

Y N
| Replace the Transfer Roller, REP 6.1.1.

Remove the Drum Cartridge, clean the electrical contacts, then print a test print. **The image is too light.**

Y N
| Perform SCP 6 Final Actions.

Print a test print. While the print is printing, turn off system power. Remove the Drum Cartridge and check the image formed on the drum right before the Transfer Roller. **The image is poorly formed, faint and difficult to read.**

Y N
| Check the image formed on the drum, right after the Transfer Roller. **The image is completely transferred to the paper**

Y N
| Replace the Transfer Roller, REP 6.1.1.

Continue with the procedure.

Replace the HVPS, REP 18.2.5, and print a test print. **The images is too light.**

Y N
| Perform SCP 6 Final Actions.

Replace the MCU Board, REP 18.2.2. **The image is too light.**

Y N
| Perform SCP 6 Final Actions.

Replace the ESS Board, REP 18.1.98.

IQ7 Spots

There are spots of toner randomly scattered on the page.

WARNING

Switch off the electricity to the machine. Disconnect the power cord from the customer supply while performing tasks that do not need electricity. Electricity can cause death or injury. Moving parts can cause injury.

WARNING

Do not touch the Fuser while it is hot.

Initial Actions

- Check that the paper is clean, dry, and meets specifications.
- If using recycled paper, it may have spots.
- Inspect the paper path for items, such as staples, paper clips, and paper scraps.
- Check if the defects repeat at regular intervals. If so, see IQ18.
- Check Drum surface for spots or contamination.
- Check the Fuser for wear or contamination.
- Check that the Drum Cartridge contacts are clean.



Random Spots

Figure 1 Spots example

Procedure

Check the media. **The media is clean, of the approved type, and free of defects.**

Y N
Replace the media with approved media from a freshly opened package.

Check the media path for dirt, debris, or toner residue. **The media path is clean.**

Y N
Clean the media path.

Replace the Drum Cartridge and reprint the test print. **The image contains spots.**

Y N
Perform SCP 6 Final Actions.

Remove the Transfer Roller and check for surface contamination or excessive wear. **The Transfer Roller is good.**

Y N
Replace the Transfer Roller, REP 6.1.1.

Remove the Fuser. Check for damage or debris on the rollers. **The Fuser rollers are good.**

Y N
Replace the Fuser, REP 7.1.1.

Check connections between the ESS Board and Laser Unit. **The connections are secure.**

Y N
Secure the connections.

Replace the ESS Board, REP 18.1.98.

IQ8 Blank Print

No visible image anywhere on the output.

Initial Actions

- Inspect the paper path for items, such as staples, paper clips, and paper scraps.
- Check CRU life counters. Replace components at end of life.
- Clear any obstructions in the laser light path.
- Check for multi-sheet feeds.

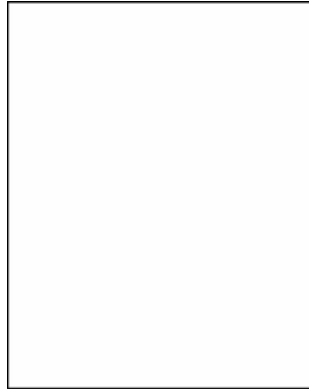

Blank Print

Figure 1 Blank print example

Procedure

WARNING

Switch off the electricity to the machine. Disconnect the power cord from the customer supply while performing tasks that do not need electricity. Electricity can cause death or injury. Moving parts can cause injury.

WARNING

Do not touch the Fuser while it is hot.

Print a test print. **The test print is blank.**

Y N
Check the customer's print job settings and the printer's Ethernet or USB connections. **Print job settings and network connections are good.**

Y N
Correct the settings or connections.

Replace the ESS Board, REP 18.1.98.

Remove the Drum Cartridge and clean the electrical contacts. Replace the Drum Cartridge and reprint the test print. **The image is blank.**

Y N
Perform SCP 6 Final Actions.

A

A

Install a new Drum Cartridge and reprint the test print. **The image is blank.**

Y N
Perform SCP 6 Final Actions.

Remove examine the Transfer Roller for surface contamination or excessive wear. **The Transfer Roller is good.**

Y N
Replace the Transfer Roller, REP 6.1.1.

Check for obstructions between the Laser Unit and Drum Cartridge. **The laser light path is clear.**

Y N
Clear the laser light path of obstructions.

Check connections to the Laser Unit from the ESS Board. **The connections are secure.**

Y N
Secure the connections.

Check HVPS connections to the bias contacts. **The connections are secure.**

Y N
Secure the connections.

Replace the HVPS, REP 18.2.5, and print a test print. **The images is blank.**

Y N
Perform SCP 6 Final Actions.

Replace the Laser Unit and reprint the test print. **The image is blank.**

Y N
Perform SCP 6 Final Actions.

Replace the MCU Board, REP 18.2.2. **The image is blank.**

Y N
Perform SCP 6 Final Actions.

Replace the ESS Board, REP 18.1.98.

IQ9 Black Print

A totally black output print. There is toner on the paper with no visible image.

WARNING

Switch off the electricity to the machine. Disconnect the power cord from the customer supply while performing tasks that do not need electricity. Electricity can cause death or injury. Moving parts can cause injury.

Initial Actions

- Inspect the paper path for items, such as staples, paper clips, and paper scraps.
- Check that the Drum Cartridge contacts are clean.
- Ensure the covers are in place and no outside light enters the printer.

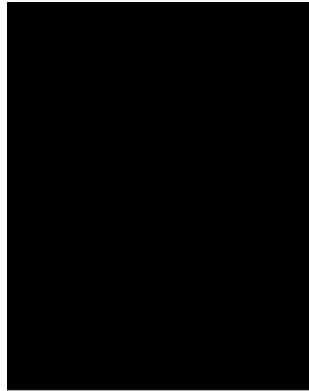

Black Print

Figure 1 Black print example

Procedure

Print a test print. **The test print is completely black.**

Y N
| Check the customer's print settings.

Remove the Drum Cartridge and clean the electrical contacts. Replace the Drum Cartridge and reprint the test print. **The image is blank.**

Y N
| Perform SCP 6 Final Actions.

Install a new Drum Cartridge and reprint the test print. **The image is blank.**

Y N
| Perform SCP 6 Final Actions.

Check HVPS connections to the bias contacts. **The connections are secure.**

Y N
| Secure the connections.

A

A

Replace the HVPS, REP 18.2.5, and print a test print. **The image is blank.**

Y N
| Perform SCP 6 Final Actions.

Replace the Laser Unit and reprint the test print. **The image is blank.**

Y N
| Perform SCP 6 Final Actions.

Replace the MCU Board, REP 18.2.2. **The image is blank.**

Y N
| Perform SCP 6 Final Actions.

Replace the ESS Board, REP 18.1.98.

IQ10 Process Streaks

Extraneous vertical dark lines or bands.

WARNING

Switch off the electricity to the machine. Disconnect the power cord from the customer supply while performing tasks that do not need electricity. Electricity can cause death or injury. Moving parts can cause injury.

WARNING

Do not touch the Fuser while it is hot.

Initial Actions

- Check that the paper supply is dry and meets specifications.
- Inspect the paper path for items, such as staples, paper clips, and paper scraps.
- Check that the Drum Cartridge contacts are clean.
- Inspect the media path for contamination or obstruction.

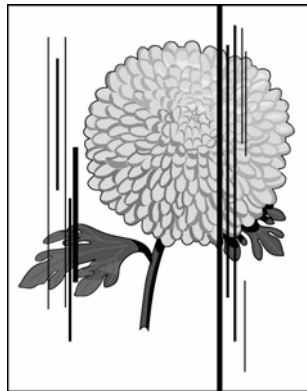

Vertical Stripes

Figure 1 Process streak example

Procedure

Check the media. **The media is clean, of the approved type, and free of defects.**

Y N

Replace the media with approved media from a freshly opened package.

Check the media path for dirt, debris, or toner residue. **The media path is clean.**

Y N

Clean the media path.

Replace the Drum Cartridge and reprint the test print. **The image contains vertical streaks.**

Y N

Perform SCP 6 Final Actions.

A

A

Remove the Transfer Roller and check for surface contamination or excessive wear. **The Transfer Roller is good.**

Y N

Replace the Transfer Roller, REP 6.1.1.

Remove and examine the Fuser for damage or debris on the rollers. **The Fuser rollers are good.**

Y N

Replace the Fuser, REP 7.1.1.

Check connections between the ESS Board and Laser Unit. **The connections are secure.**

Y N

Secure the connections.

Replace the ESS Board, REP 18.1.98.

IQ11 Scan Streaks

There are black lines running horizontally across the page.

WARNING

Switch off the electricity to the machine. Disconnect the power cord from the customer supply while performing tasks that do not need electricity. Electricity can cause death or injury. Moving parts can cause injury.

WARNING

Do not touch the Fuser while it is hot.

Initial Actions

- Check that the paper supply is dry and meets specifications.
- Inspect the paper path for items, such as staples, paper clips, and paper scraps.
- Check the Drum Cartridge Drum surface for scratches.
- Check the Drum Cartridge contacts.

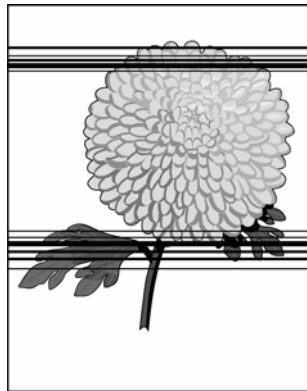

Horizontal Stripes

Figure 1 Horizontal streaks example

Procedure

Check the media. **The media is clean, of the approved type, and free of defects.**

- Y N
| Replace the media with approved media from a freshly opened package.

Check the media path for dirt, debris, or toner residue. **The media path is clean.**

- Y N
| Clean the media path.

Remove the Drum Cartridge and clean the electrical contacts. Replace the Drum Cartridge and reprint the test print. **The image has horizontal streaks.**

- Y N
| Perform SCP 6 Final Actions.

A

A

Install a new Drum Cartridge and reprint the test print. **The image has horizontal streaks.**

- Y N
| Perform SCP 6 Final Actions.

Remove the Transfer Roller and check for surface contamination or excessive wear. **The Transfer Roller is good.**

- Y N
| Replace the Transfer Roller, REP 6.1.1.

Check for debris on the Laser Unit window or obstructions between the Laser Unit and Drum Cartridge. **The laser path is clear.**

- Y N
| Clear the laser path of obstructions.

Remove and examine the Fuser for damage or debris on the rollers. **The Fuser rollers are good.**

- Y N
| Replace the Fuser, REP 7.1.1.

Check HVPS connections to the bias contacts. **The connections are secure.**

- Y N
| Secure the connections.

Replace the HVPS, REP 18.2.5, and print a test print. **The images is blank.**

- Y N
| Perform SCP 6 Final Actions.

Check connections between the ESS Board and Laser Unit. **The connections are secure.**

- Y N
| Secure the connections.

Replace the ESS Board, REP 18.1.98.

IQ12 Damaged Print

The page comes out of the Output Tray either wrinkled, creased, or torn.

WARNING

Switch off the electricity to the machine. Disconnect the power cord from the customer supply while performing tasks that do not need electricity. Electricity can cause death or injury. Moving parts can cause injury.

WARNING

Do not touch the Fuser while it is hot.

NOTE: If paper damage occurs within an installed option, determine the location where the damage occurs as correct as necessary to eliminate the problem.

Initial Actions

- Check media type settings are correct.
- Check that chutes operate properly when doors or covers are opened or closed.
- Check that the paper supply is dry and meets specifications.
- Inspect the paper path for items, such as staples, paper clips, and paper scraps.
- Check that rollers and other paper path components are clean and unobstructed.
- For envelopes, ensure that the "Envelope Fuser" (604K98010) is installed. The envelope fuser has levers to reduce fuser pressure.

Procedure

Check that the printer is level, has its feet, and has adequate airflow. **The installation location is within specification.**

Y N
| Correct the installation.

Check the media. **The media is clean, of the approved type, and free of defects.**

Y N
| Replace the media with approved media from a freshly opened package.

Change the media. **The media damage persists.**

Y N
| Replace the media in all trays. Remove bad media from stock.

Check the media path for dirt, debris, or toner residue. **The media path is clean.**

Y N
| Clean the media path.

Check rollers in the paper path.

1. Check feed and media path rollers for contamination, wear, or damage.
2. Check whether the pinch rollers rotate freely and spring pressure is applied evenly.

The rollers are good.

Y N
| Replace worn or damaged rollers.

Remove and examine the Fuser for damage or debris on the rollers. **The Fuser rollers are good.**

Y N
| Replace the Fuser, REP 7.1.1.

A

A

Remove the Transfer Roller and check for surface contamination or excessive wear. **The Transfer Roller is good.**

Y N
| Replace the Transfer Roller, REP 6.1.1.

Replace the following, in order, until the defective component is found.

- Feed and transport rollers
- Fuser, REP 7.1.1
- Transfer Roller, REP 6.1.1
- Exit Chute Assembly, REP 17.1.99

IQ13 Repeating Defects

Recurring marks, spots, lines, or voids.

WARNING

Switch off the electricity to the machine. Disconnect the power cord from the customer supply while performing tasks that do not need electricity. Electricity can cause death or injury. Moving parts can cause injury.

WARNING

Do not touch the Fuser while it is hot.

Initial Actions

- Check that the paper is clean, dry, and meets specifications.
- Inspect the paper path for items, such as staples, paper clips, and paper scraps.
- Check CRU life counts. Replace components at end of life.



Repeating Defects

Figure 1 Repeating defects example

Procedure

Check the media. **The media is clean, of the approved type, and free of defects.**

Y N

Replace the media with approved media from a freshly opened package.

Check the media path for dirt, debris, or toner residue. **The media path is clean.**

Y N

Clean the media path.

Print a test print and compare the defect to the values listed in Table 1. Replace the defective component.

Xerographic Component Dimensions

Table 1 lists measurements of critical printer components. Refer to these measurements when diagnosing a repeating print-quality problem.

Table 1 Xerographic Component Specifications

Component	Circumference
OPC Drum (Drum Cartridge)	94.4 mm (3.7 inches)
Registration Roller	59.1 mm (inches)
Feed Roller	47.1 mm (1.85 inches)
Nudger, Pick, Seperator Rollers	72.3 mm (inches)
Tray 1 Pick Roller	47.1 mm (1.85 inches)
Fuser Heat Roller	155 mm (inches)
Duplex Roller	35.5 mm (1.4 inches)
Cleaning Roller (Drum Cartridge)	40.8 mm
Transfer Roller	57.8 mm

IQ14 Residual Image

The image from a previous print appears on the current print.

WARNING

Switch off the electricity to the machine. Disconnect the power cord from the customer supply while performing tasks that do not need electricity. Electricity can cause death or injury. Moving parts can cause injury.

WARNING

Do not touch the Fuser while it is hot.

Initial Actions

- Check media type settings are correct.
- Inspect the paper path for items, such as staples, paper clips, and paper scraps.
- Check Drum Cartridge installation.
- Clean the Drum Cartridge contact points.
- Verify the paper is within specifications.



Residual Image/Ghosting

Figure 1 Residual image (ghosting) example

Procedure

Print 10 test prints. **A residual image appears on all copies.**

Y N

Print an additional 10 prints to clean residual toner from the rollers.

Measure the defect frequency on the prints. **No defect pattern is visible.**

Y N

Refer to IQ13 Repeating Defects to determine the defective component.

Remove the Drum Cartridge and clean the electrical contacts. Replace the Drum Cartridge and reprint the test print. **The residual image defect is still visible.**

Y N

Perform SCP 6 Final Actions.

A

A

Install a new Drum Cartridge and reprint the test print. **The residual image defect is still visible.**

Y N

Perform SCP 6 Final Actions.

Remove the Transfer Roller and check for surface contamination or excessive wear. **The Transfer Roller is good.**

Y N

Replace the Transfer Roller, REP 6.1.1.

Remove and examine the Fuser for damage or debris on the rollers. **The Fuser rollers are good.**

Y N

Replace the Fuser, REP 7.1.1.

Replace the following, in order, until the defective component is found.

- Drum Cartridge, REP 8.1.1
- Transfer Roller, REP 6.1.1
- Fuser, REP 7.1.1
- HVPS, REP 18.2.5

IQ15 Background

There is toner contamination on all or part of the page. The contamination appears as a very light gray dusting.

WARNING

Switch off the electricity to the machine. Disconnect the power cord from the customer supply while performing tasks that do not need electricity. Electricity can cause death or injury. Moving parts can cause injury.

WARNING

Do not touch the Fuser while it is hot.

NOTE: Glossy media may show some backgrounding due to the surface texture.

Initial Actions

- Check media type settings are correct.
- Check that the paper is clean, dry, and meets specifications.
- Verify the Toner Cartridge is a Xerox manufactured part with adequate life remaining. If a non-Xerox Toner Cartridge is being used, this could be the problem.
- Check for excessive humidity.
- Clean the Drum Cartridge contacts.
- Ensure covers are in place and no outside light enters the printer.



Background Contamination

Figure 1 Background defect example

Procedure

Check the paper condition. Load new, dry recommended paper, and print a test print. **The image includes background defects.**

Y N
Perform SCP 6 Final Actions.

Remove the Drum Cartridge, clean the electrical contacts, then print a test print. **The image includes background defects.**

Y N
Perform SCP 6 Final Actions.

Replace the Drum Cartridge and reprint the test print. **The image includes background defects.**

Y N
Perform SCP 6 Final Actions.

Remove examine the Transfer Roller for surface contamination or excessive wear. **The Transfer Roller is good.**

Y N
Replace the Transfer Roller, REP 6.1.1.

Print a test print. While the print is printing, turn off system power. Remove the Drum Cartridge and check the image formed on the drum right before the Transfer Roller. **The image is poorly formed, faint and difficult to read.**

Y N
Check the image formed on the drum, right after the Transfer Roller. **The image is completely transferred to the paper**

Y N
Replace the Transfer Roller, REP 6.1.1.

Continue with the procedure.

Replace the HVPS, REP 18.2.5, and print a test print. **The image includes background defects.**

Y N
Perform SCP 6 Final Actions.

Replace the MCU Board, REP 18.2.2. **The image includes background defects.**

Y N
Perform SCP 6 Final Actions.

Replace the ESS Board, REP 18.1.98.

IQ16 Uneven Density

Image density varies across the page in either direction.

WARNING

Switch off the electricity to the machine. Disconnect the power cord from the customer supply while performing tasks that do not need electricity. Electricity can cause death or injury. Moving parts can cause injury.

WARNING

Do not touch the Fuser while it is hot.

Initial Actions

- Check media type settings.
- Load new, dry paper that meets specifications.
- Check Toner Cartridge installation and life count.
- Ensure that the printer is level.
- Check the laser light path is clean and unobstructed.

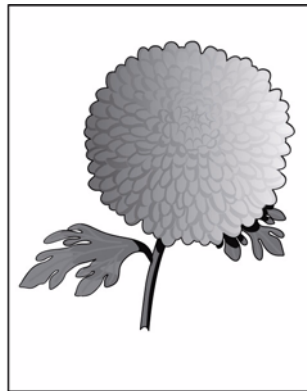

Density Uneven or Wrong (Scan Direction)

Figure 1 Uneven density defect example

Procedure

Check the paper condition. Load new, dry recommended paper, and print a test print. **The image includes density defects.**

Y N
Perform SCP 6 Final Actions.

Remove the Drum Cartridge, clean the electrical contacts, then print a test print. **The image has density defects.**

Y N
Perform SCP 6 Final Actions.

Replace the Drum Cartridge and reprint the test print. **The image has density defects.**

Y N
Perform SCP 6 Final Actions.

Remove and examine the Transfer Roller for surface contamination or excessive wear. **The Transfer Roller is good.**

Y N
Replace the Transfer Roller, REP 6.1.1.

Print a test print. While the print is printing, turn off system power. Remove the Drum Cartridge and check the image formed on the drum right before the Transfer Roller. **The image is poorly formed, faint and difficult to read.**

Y N
Check the image formed on the drum, right after the Transfer Roller. **The image is completely transferred to the paper**

Y N
Replace the Transfer Roller, REP 6.1.1.

Continue with the procedure.

Remove and examine the Fuser for damage or debris on the rollers. **The Fuser rollers are good.**

Y N
Replace the Fuser, REP 7.1.1.

Replace the following, in order, until the defective component is found.

- Transfer Roller, REP 6.1.1
- Fuser, REP 7.1.1

IQ17 Stains on Print Back

Use this procedure when printed sheets have stains on the non-image side of the paper.

WARNING

Switch off the electricity to the machine. Disconnect the power cord from the customer supply while performing tasks that do not need electricity. Electricity can cause death or injury. Moving parts can cause injury.

WARNING

Do not touch the Fuser while it is hot.

Initial Actions

- Ensure that the printer is level.

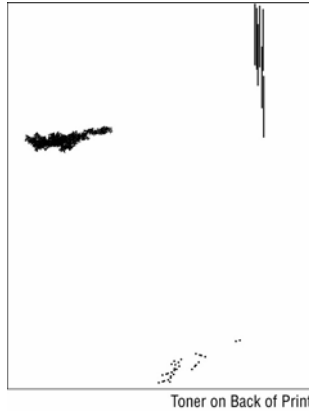

Figure 1 Toner on the back of prints

Procedure

Print 10 test prints. **A staining appears on all copies.**

Y N
| Print an additional 10 prints to clean residual toner from the rollers.

Remove and examine the Transfer Roller for surface contamination or excessive wear. **The Transfer Roller is good.**

Y N
| Replace the Transfer Roller, REP 6.1.1.

Remove and examine the Fuser for damage or debris on the rollers. **The Fuser rollers are good.**

Y N
| Replace the Fuser, REP 7.1.1.

Replace the following, in order, until the defective component is found.

- Transfer Roller, REP 6.1.1
- Fuser, REP 7.1.1

IQ18 Registration

The image is positioned incorrectly in either the process or scan direction.

Initial Actions

- Check the Duplex Unit media size setting on the Duplex Unit.
- Check the customer's application settings.
- Check that the paper supply is new, dry, and loaded correctly.
- Check that the paper tray guides are set correctly.
- Check that components in the paper path are clean and unobstructed.

If registration defects occur on duplex prints only, replace the Duplex Chute. If registration defects occur on prints sourced from all trays in the process direction, replace the Transport Assembly.

If registration defects occur from a specific tray in the process direction, check these components in sequence and replace as necessary:

- Feed, Nudger, Retard Rollers, REP 9.2.98
- Feed Clutch, REP 15.2.16
- Transport Assembly, REP 15.1.6

If registration defects occur in the cross-process direction, check these components in sequence and replace as necessary:

- Laser Unit, REP 2.1.1
- ESS Board, REP 18.1.98
- Drum Cartridge, REP 8.1.1
- Tray, PL 9.2 Item 1

To make Lead Edge Registration adjustments, use dC131 to adjust NVRAM values (attached).

Procedure

Measure the registration on two consecutive test prints. **Registration is within specification, refer to IQS 3.**

Y N
| Go to ADJ 8.1 **Lead Edge Registration.**

Perform IQ5 Skew.

IQ19 Curved Vertical Lines

When printing, vertical lines are not straight.

WARNING

Switch off the electricity to the machine. Disconnect the power cord from the customer supply while performing tasks that do not need electricity. Electricity can cause death or injury. Moving parts can cause injury.

Initial Actions

- Cycle system power.
- Check connections from the HVPS to the Drum Cartridge.
- Check AC supply and power cord. Plug printer directly into wall outlet.

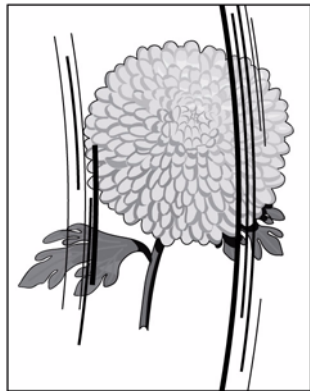

Curved Vertical Stripes

Figure 1 Curved vertical lines defect example

Test Prints

Listed below are the test patterns available to help identify and locate image quality defects.

- Gradation ESS
- Ghost Chart ESS
- Test pattern 1 (letter/A4)
- 100% Solid (Black)
- 20% halftone (Grey Scale)
- Total PQ Chart (letter/A4)
- Alignment Chart (letter/A4)
- Halftone Representation Chart (letter/A4)

Procedure

Remove the Drum Cartridge and clean the electrical contacts. Replace the Drum Cartridge and print a test print. **The vertical curved lines defect is visible.**

Y N
Perform SCP 6 Final Actions

Check HVPS operation and bias contacts to the Drum Cartridge. **The HVPS is good.**

Y N
Replace the HVPS, REP 18.2.5.

Check connections between the Laser Unit and ESS Board. **The connections are secure.**

Y N
Replace the Laser Unit, REP 2.1.1.

Replace the MCU Board, REP 18.2.2.

IQS 1 Solid Area Density

Documents

Test pattern: 82P524 and the solid area density scales, 82E8230 (SIR 542.00) or 82P448 (SIR 494.00).

The WorkCentre 3655 is ISO11798 compliant with archival paper. Image density is no less than 90% across core media list. Media must fix toner well enough to pass taping test. Using a 500g weight, after rubbing the test pattern 5 times, calculate the ratio of pre- and post- test data (density).

After taping test, the image density of black area of test pattern should be higher than 80% of its original density in standard paper under N/N environmental condition.

Specification

Make a copy of the test pattern. Compare the copy with the solid area density scale. The density of the 1.0 areas on the copy of the test pattern, must be as dark or darker than the 0.8 reference on the solid area density scale.

Corrective Action

Go to the IQ1 Image Quality Entry RAP.

IQS 2 Skew

Documents

Test pattern: 82P524 (8.5 x 14), 82E2020 (8.5 x 11) or 82E2010 (A4).

Specifications

Refer to Table 1.

Table 1 Margin Specifications

Mode	Tray	Margin Specification (mm)		Magnification Error
		Leading Edge	Side Edge	
Simplex	Bypass / Tray 1	12.7± 1.0	12.7± 1.5	Horizontal 177.8 ±1.5mm Vertical 241.3±1.5mm
	Optional Trays	12.7± 1.5	12.7± 2.0	
Duplex	Bypass / Tray 1	12.7± 1.5	12.7± 2.0	
	Optional Trays	12.7± 2.0	12.7± 2.5	

IQS 3 Registration

Documents

Test pattern: 82P524 (8.5 x 14), 82E2020 (8.5 x 11) or 82E2010 (A4).

Specifications

Refer to Table 1.

Table 1 Registration measurement

Registration	Specification
Lead edge	+/- 2 mm
Top edge	+/- 2.5 mm

Corrective Action

Go to the [IQ18 Registration RAP](#).

IQS 4 Transparencies

CAUTION

Transparencies are not supported on the WorkCentre 3655.

IQS 5 Image Area

Specifications

Refer to Figure 1.

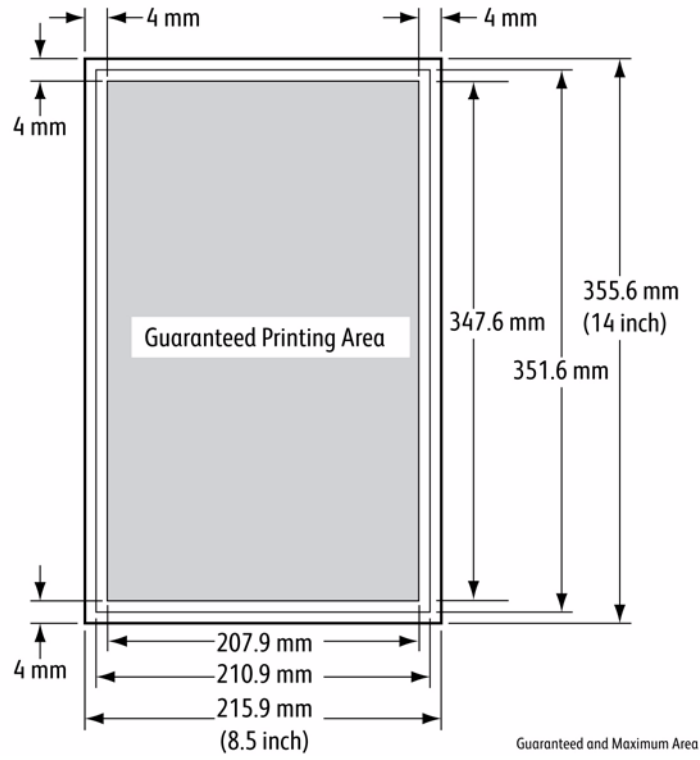

Figure 1 Image area specifications

4 Repair Procedures

REP 1.1.1 IIT Top Cover.....	4-3	REP 15.1.11 Tray 1 Stopper	4-51
REP 1.1.2 IIT Front Cover.....	4-3	REP 15.1.97 Rear Interlock Switch Assembly	4-52
REP 1.1.3 IIT Front Bottom Cover	4-4	REP 15.2.4 Registration Clutch.....	4-53
REP 1.1.4 Right UI Base Cover	4-4	REP 15.2.6 Rubber Registration Roller.....	4-53
REP 1.1.5 UI Base Bottom Cover	4-5	REP 15.2.14 Registration Sensor Shutter.....	4-56
REP 1.1.6 Left UI Base Cover	4-5	REP 15.2.16 Feed Clutch.....	4-56
REP 1.2.1 Control Panel Assembly	4-6	REP 17.1.1 Exit Sensor.....	4-57
REP 1.2.2 Upper Rear UI Cover	4-7	REP 17.1.5 Exit Roller.....	4-57
REP 1.2.3 UI Hinge Cover	4-7	REP 17.1.6 Pinch Rollers.....	4-58
REP 1.2.9 UI Cable.....	4-8	REP 17.1.9 Full Stack Sensor.....	4-58
REP 1.2.98 UI Hinge Assembly	4-9	REP 17.1.99 Exit Chute Assembly.....	4-59
REP 2.1.1 Laser Unit	4-10	REP 18.1.1 ESS Housing Cover.....	4-60
REP 3.1.1 Main Drive Assembly	4-12	REP 18.1.2 ESS Housing.....	4-61
REP 3.1.2 Exit Drive Assembly	4-13	REP 18.1.4 IIT Control Board.....	4-62
REP 3.1.3 Exit Invert Drive Assembly	4-17	REP 18.1.7 Fax Board	4-63
REP 3.1.4 Duplex Gear and Holder	4-20	REP 18.1.10 Size Switch	4-64
REP 4.1.1 LVPS Fan	4-21	REP 18.1.12 LVPS.....	4-64
REP 4.1.3 Front Links	4-22	REP 18.1.14 Side USB Assembly.....	4-65
REP 5.1.5 Dispense Drive Assembly.....	4-22	REP 18.1.16 Front Interlock Switch Assembly.....	4-66
REP 5.1.9 Toner Dispense Motor	4-25	REP 18.1.17 RAM.....	4-66
REP 5.1.10 Xerographic Connector.....	4-27	REP 18.1.96 SD Card	4-67
REP 5.1.99 Toner CRUM Assembly	4-28	REP 18.1.97 Hard Drive.....	4-67
REP 6.1.1 Transfer Roller	4-29	REP 18.1.98 ESS Board.....	4-68
REP 7.1.1 Fuser.....	4-30	REP 18.2.2 MCU Board	4-69
REP 8.1.1 Drum Cartridge	4-30	REP 18.2.5 HVPS.....	4-70
REP 8.1.2 Toner Cartridge.....	4-31	REP 18.2.6 Stapler Assembly.....	4-71
REP 9.2.98 Feed Roll Kit	4-31	REP 18.2.9 Stapler LVPS	4-72
REP 9.2.99 Retard Roll Kit.....	4-32	REP 18.4.99 AC Inlet Harness.....	4-73
REP 11.1.2 Optional Feeder Left Side Cover	4-32	REP 19.1.10 Right Side Cover.....	4-74
REP 11.1.5 Optional Feeder Board	4-33	REP 19.1.11 Stapler Cover.....	4-74
REP 11.1.7 Optional Feeder Drive.....	4-33	REP 19.1.12 Stapler Cartridge Cover	4-75
REP 11.1.8 Optional Feeder Feed Clutch.....	4-34	REP 19.1.13 Outer Right Cover	4-75
REP 11.1.20 Optional Feeder Feed Assembly	4-34	REP 19.1.14 Inner Right Cover.....	4-76
REP 11.1.27 Optional Feeder Tray Stopper	4-35	REP 19.1.96 Front Cover Assembly	4-76
REP 11.1.99 Optional 550-Sheet Feeder	4-36	REP 19.1.97 Top Cover Assembly.....	4-77
REP 11.2.2 Optional Feeder No Paper Sensor	4-36	REP 19.1.98 Stapler Cover Assembly	4-78
REP 11.2.11 Optional Feeder No Paper Sensor Acuator	4-37	REP 19.1.99 Output Tray Extension	4-79
REP 11.2.20 Optional Feeder Registration Clutch.....	4-37	REP 19.2.1 Left Side Cover	4-79
REP 11.2.21 Optional Feeder Take Away Roller.....	4-38	REP 19.2.2 Left Rear Cover.....	4-81
REP 11.4.4 Optional Feeder Path Sensor	4-39	REP 19.2.3 Lower Rear Cover.....	4-81
REP 13.1.5 MSI Feed Solenoid	4-39	REP 19.2.5 SubLV Harness Guide	4-82
REP 13.1.15 MSI Pick-up Holder Assembly	4-41	REP 19.2.99 Exit Cover Assembly.....	4-85
REP 13.1.97 Top Frame Assembly.....	4-41	REP 19.3.9 Rear Fan	4-85
REP 13.2.9 Bypass Tray.....	4-42	REP 19.3.99 Rear Cover Assembly.....	4-87
REP 13.2.98 MSI Retard Roller Assembly.....	4-42	REP 21.1.1 DADF Assembly.....	4-89
REP 14.1.2 Duplex Roller Assembly.....	4-43	REP 21.1.9 DADF Hinges	4-91
REP 14.1.12 Duplex Chute Assembly	4-44	REP 21.1.11 DADF Input Tray Assembly	4-91
REP 15.1.6 Registration Assembly.....	4-45	REP 21.1.14 Scanner.....	4-93

REP 21.1.97 DADF Pick-up Assembly	4-94
REP 21.1.98 DADF Top Cover Assembly.....	4-95

ADJ 8.1 Lead Edge Registration.....	4-96
-------------------------------------	------

4. Adjustments

REP 1.1.1 IIT Top Cover

Parts List on PL 1.1 Item 1

Removal

WARNING

Switch off the electricity to the machine. Disconnect the power cord from the customer supply while performing tasks that do not need electricity. Electricity can cause death or injury. Moving parts can cause injury.

1. Lift the DADF.
2. Refer to Figure 1 to locate and remove 1 screw (silver, M3, 6mm) that secures the cover.
3. Slide the cover left to release 5 hooks and remove.

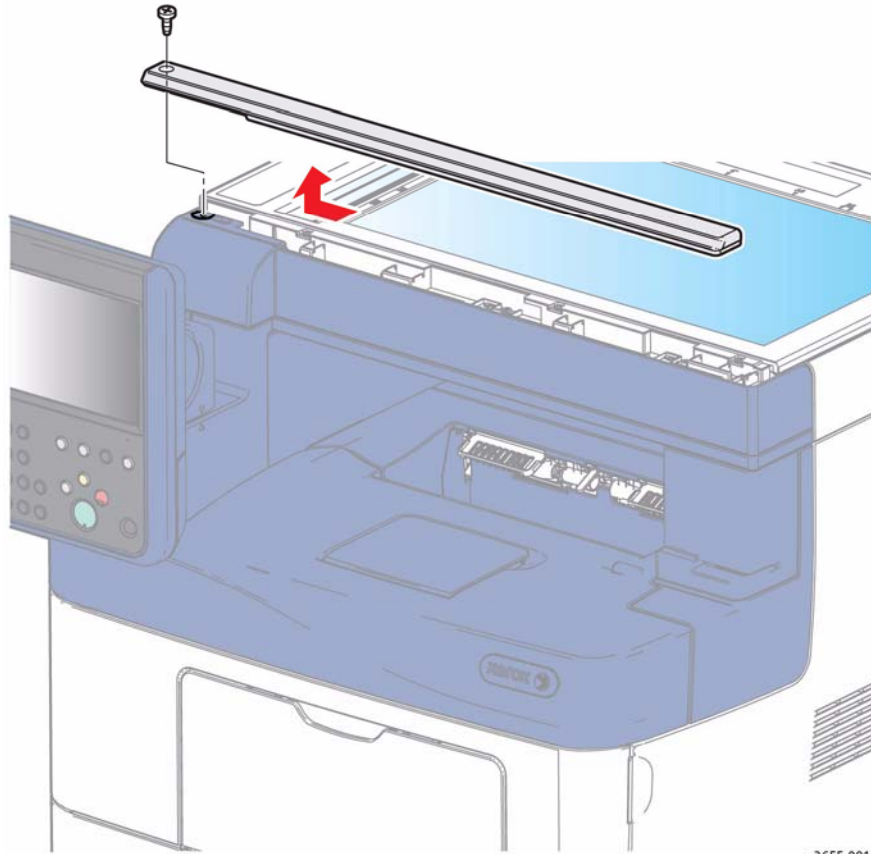

Figure 1 Remove the IIT Top Cover

s3655-001

REP 1.1.2 IIT Front Cover

Parts List on PL 1.1 Item 2

Removal

WARNING

Switch off the electricity to the machine. Disconnect the power cord from the customer supply while performing tasks that do not need electricity. Electricity can cause death or injury. Moving parts can cause injury.

1. Remove the IIT Top Cover, REP 1.1.1.
2. Open the Front Cover.
3. Remove the Left UI Base Cover, REP 1.1.6
4. Refer to Figure 1 to locate and remove 2 screws (silver, M3, 6mm) that secure the cover.
5. Lift the cover from the 2 center bosses and release 3 hooks to remove.

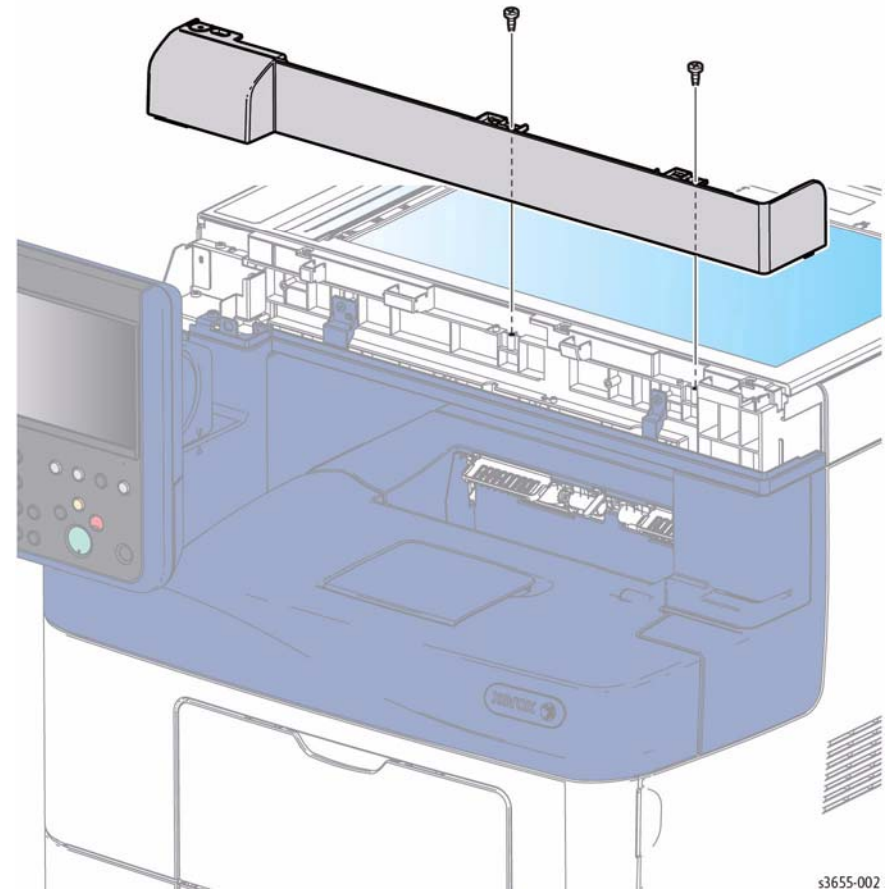

Figure 1 Remove the IIT Front Cover

s3655-002

REP 1.1.3 IIT Front Bottom Cover

Parts List on PL 1.1 Item 3

Removal

WARNING

Switch off the electricity to the machine. Disconnect the power cord from the customer supply while performing tasks that do not need electricity. Electricity can cause death or injury. Moving parts can cause injury.

1. Remove the IIT Top Cover, REP 1.1.1.
2. Open the Front Cover.
3. Remove the Left UI Base Cover, REP 1.1.6
4. Remove the IIT Front Cover, REP 1.1.2.
5. Remove the Right UI Base Cover, REP 1.1.4.
6. Remove the Stapler Cover, REP 19.1.11 or Outer Right Cover, REP 19.1.13.
7. Refer to Figure 1 to locate and remove 2 screws (silver, M3, 6mm), then pull forward at the right end to remove.

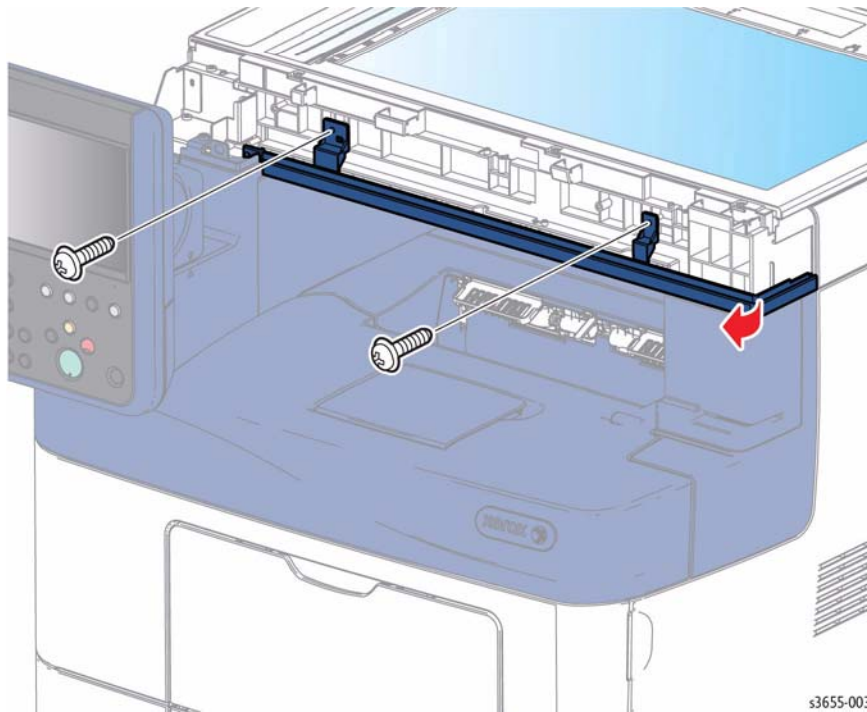

Figure 1 Remove the IIT Front Bottom Cover

REP 1.1.4 Right UI Base Cover

Parts List on PL 1.1 Item 4

Removal

WARNING

Switch off the electricity to the machine. Disconnect the power cord from the customer supply while performing tasks that do not need electricity. Electricity can cause death or injury. Moving parts can cause injury.

1. Remove the IIT Top Cover, REP 1.1.1.
2. Open the Front Cover.
3. Remove the Left UI Base Cover, REP 1.1.6
4. Remove the IIT Front Cover, REP 1.1.2.
5. Refer to Figure 1 to locate and remove 2 screws (metal, 6mm), then slide the cover forward to remove.

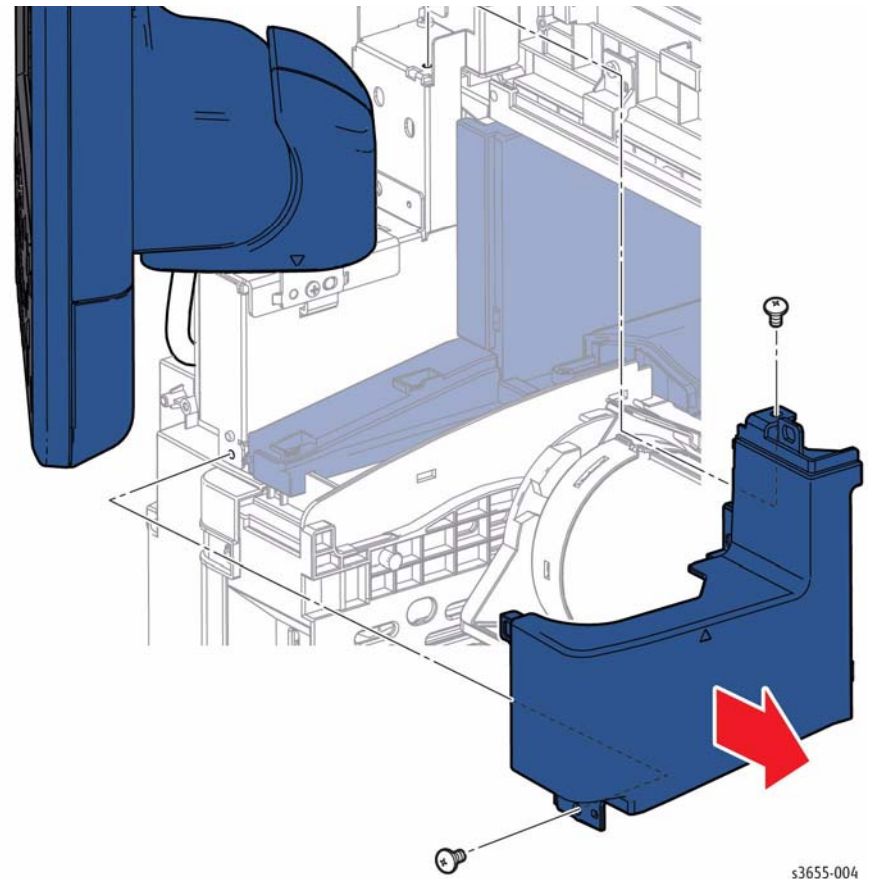

Figure 1 Remove the Right UI Base Cover

REP 1.1.5 UI Base Bottom Cover

Parts List on PL 1.1 Item 5

Removal

WARNING

Switch off the electricity to the machine. Disconnect the power cord from the customer supply while performing tasks that do not need electricity. Electricity can cause death or injury. Moving parts can cause injury.

1. Remove the IIT Top Cover, REP 1.1.1.
2. Open the Front Cover.
3. Remove the Left UI Base Cover, REP 1.1.6.
4. Remove the IIT Front Cover, REP 1.1.2.
5. Remove the Right UI Base Cover, REP 1.1.4.
6. Refer to Figure 1 to locate and remove 1 screw (silver, tapping, M3, 8mm) to remove the cover.

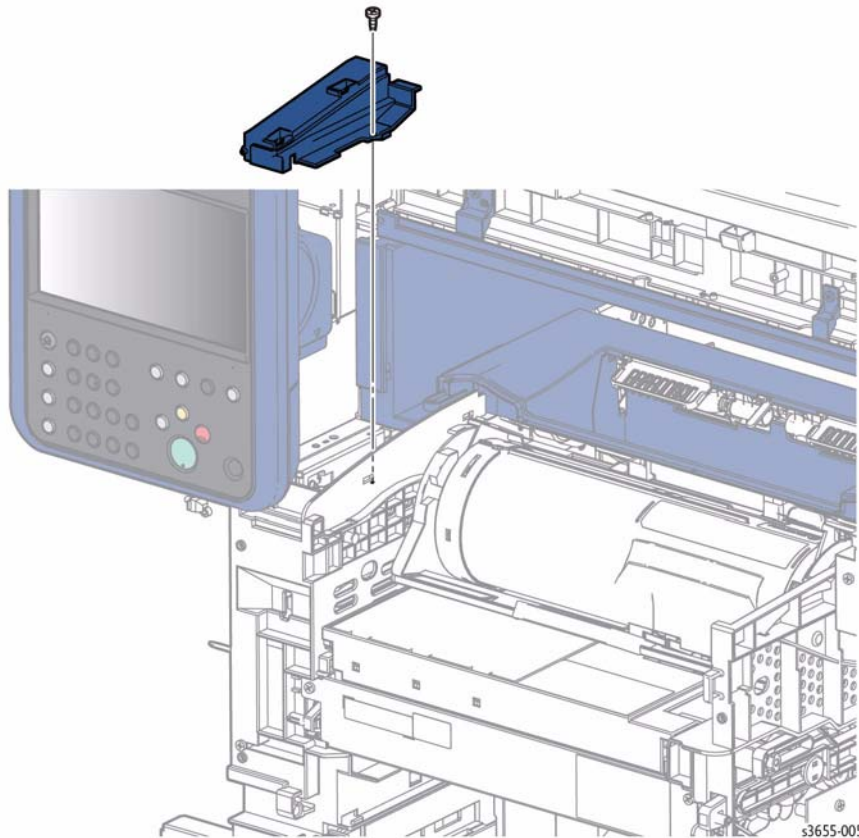

Figure 1 Remove the UI Base Bottom Cover

REP 1.1.6 Left UI Base Cover

Parts List on PL 1.1 Item 6

Removal

WARNING

Switch off the electricity to the machine. Disconnect the power cord from the customer supply while performing tasks that do not need electricity. Electricity can cause death or injury. Moving parts can cause injury.

1. Open the Front Cover.
2. Refer to Figure 1 to locate and remove 1 screw (silver, M3, 6mm) to remove the cover.

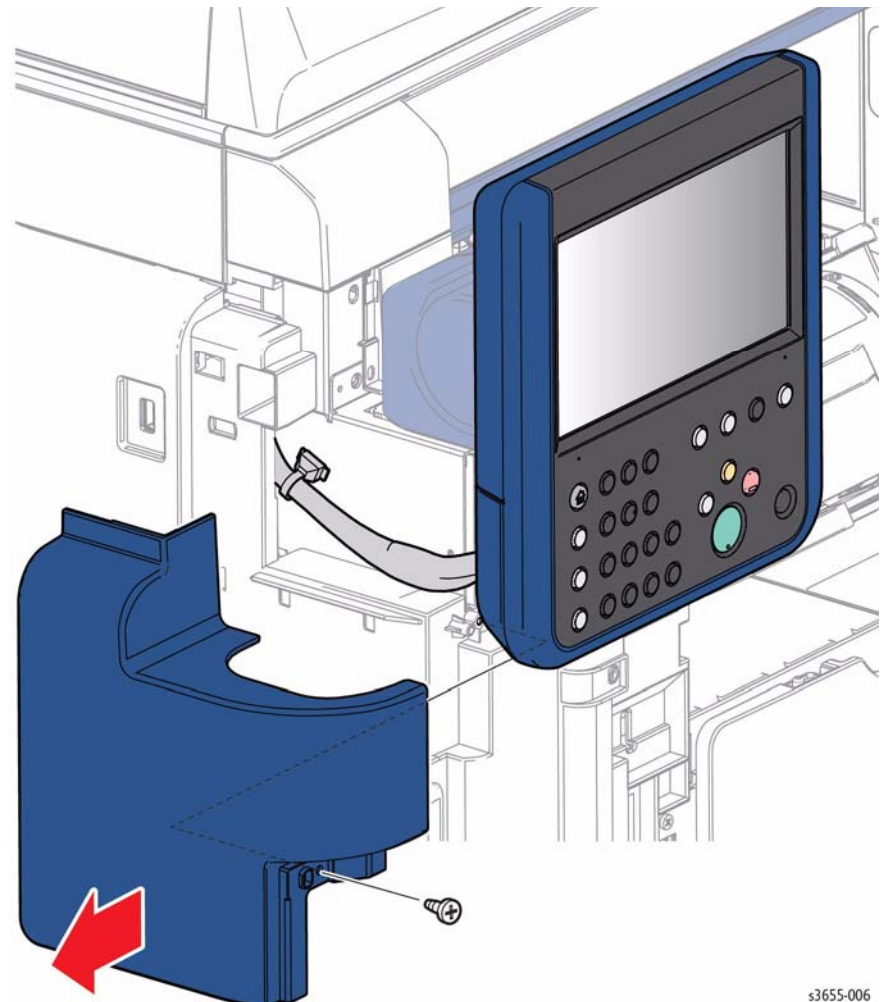

Figure 1 Remove the Left UI Base Cover

REP 1.2.1 Control Panel Assembly

Parts List on PL 1.2 Item 1

Removal

WARNING

Switch off the electricity to the machine. Disconnect the power cord from the customer supply while performing tasks that do not need electricity. Electricity can cause death or injury. Moving parts can cause injury.

CAUTION

The UI Cable connector is easily damaged. Use care when connecting, disconnecting, and routing the UI Cable through the UI Hinge Assembly.

1. Remove the UI Hinge Cover, REP 1.2.3.
2. Remove the Upper Rear UI Cover, REP 1.2.2.
3. Refer to Figure 1 to locate and remove 1 screw and 1 tie that secure the UI cable to the Control Panel.

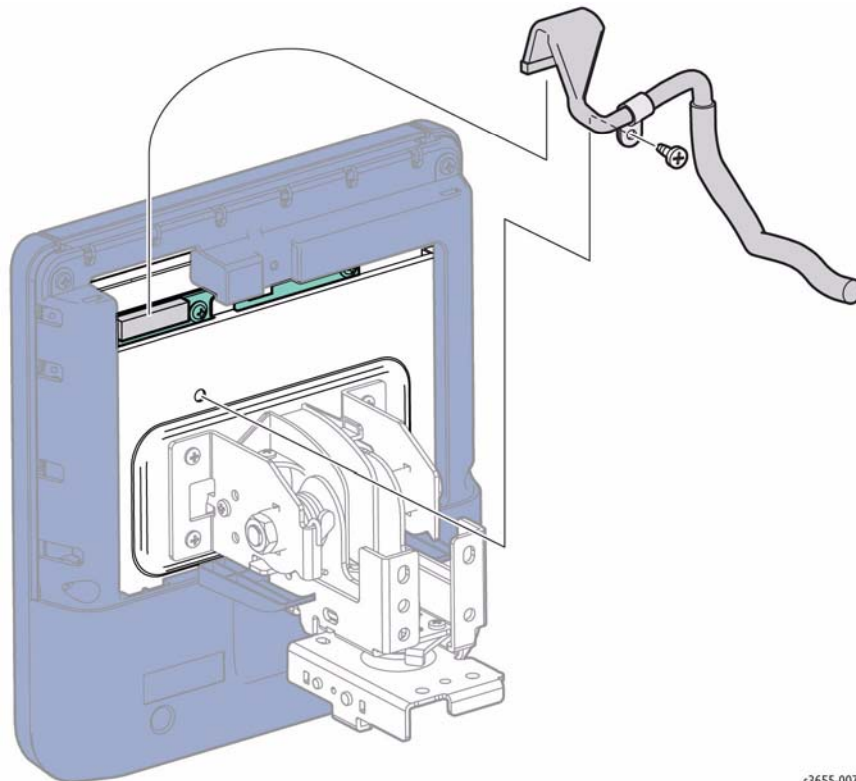

Figure 1 Disconnect the Control Panel

4. Disconnect the UI cable from the Control Panel.

5. Refer to Figure 2 to locate and remove 4 screws (silver, M3, 6mm) that secure the Control Panel to the UI Hinge Assembly.

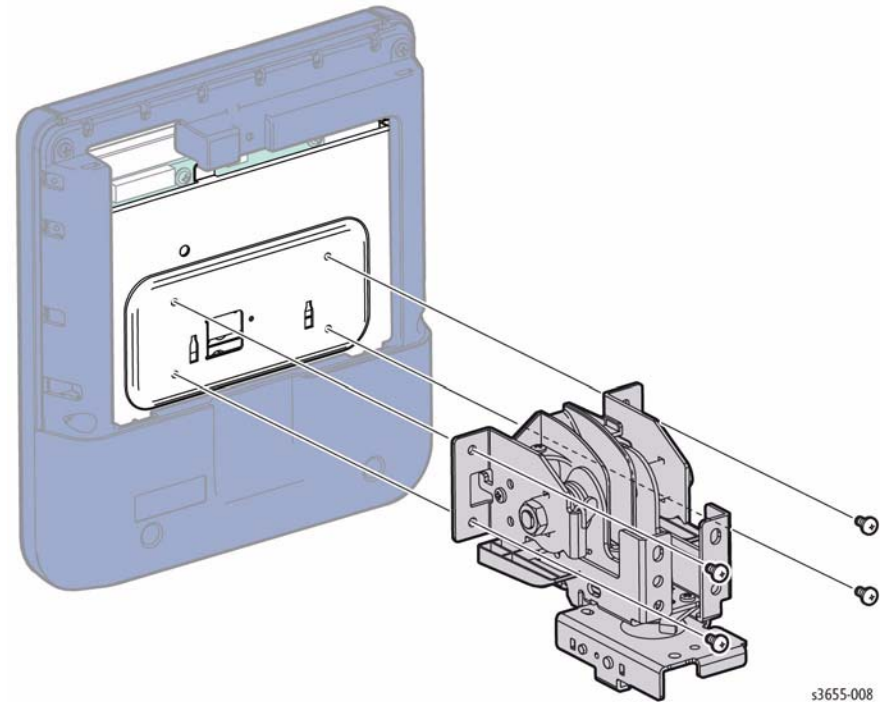

Figure 2 Remove the UI Hinge Assembly

REP 1.2.2 Upper Rear UI Cover

Parts List on PL 1.2 Item 2

Removal

WARNING

Switch off the electricity to the machine. Disconnect the power cord from the customer supply while performing tasks that do not need electricity. Electricity can cause death or injury. Moving parts can cause injury.

1. Remove the UI Hinge Cover, REP 1.2.3.
2. Refer to Figure 1 to locate and remove 1 screw (silver, tapping, M3, 8mm) that secures the cover.

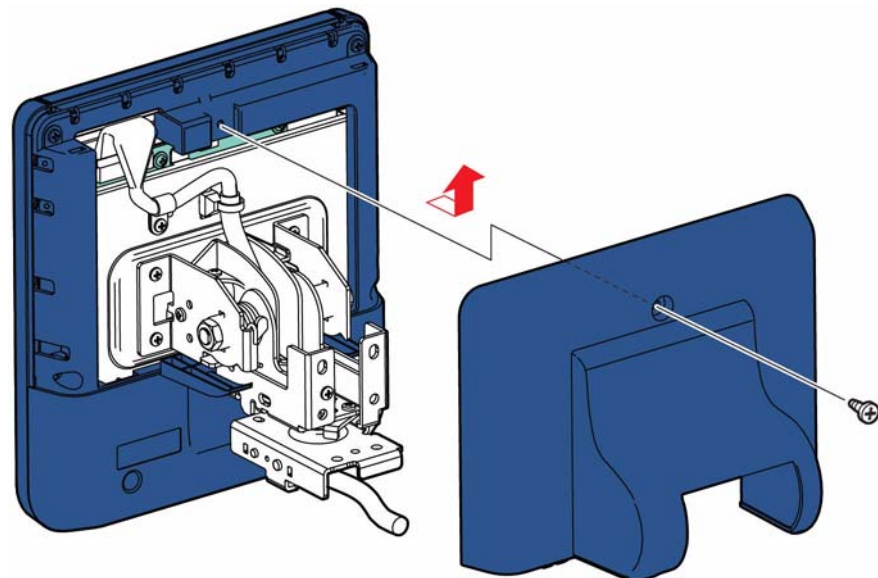

Figure 1 Remove the Upper Rear UI Cover

s3655-009

REP 1.2.3 UI Hinge Cover

Parts List on PL 1.2 Item 3, PL 1.2 Item 4

Removal

The UI Hinge Cover consists of two parts (left and right) held together on the UI Hinge Assembly by a single screw.

WARNING

Switch off the electricity to the machine. Disconnect the power cord from the customer supply while performing tasks that do not need electricity. Electricity can cause death or injury. Moving parts can cause injury.

1. Refer to Figure 1 to locate and remove 1 screw (silver, M3, 6mm) that secures the covers.
2. Pull the covers apart to separate and remove.

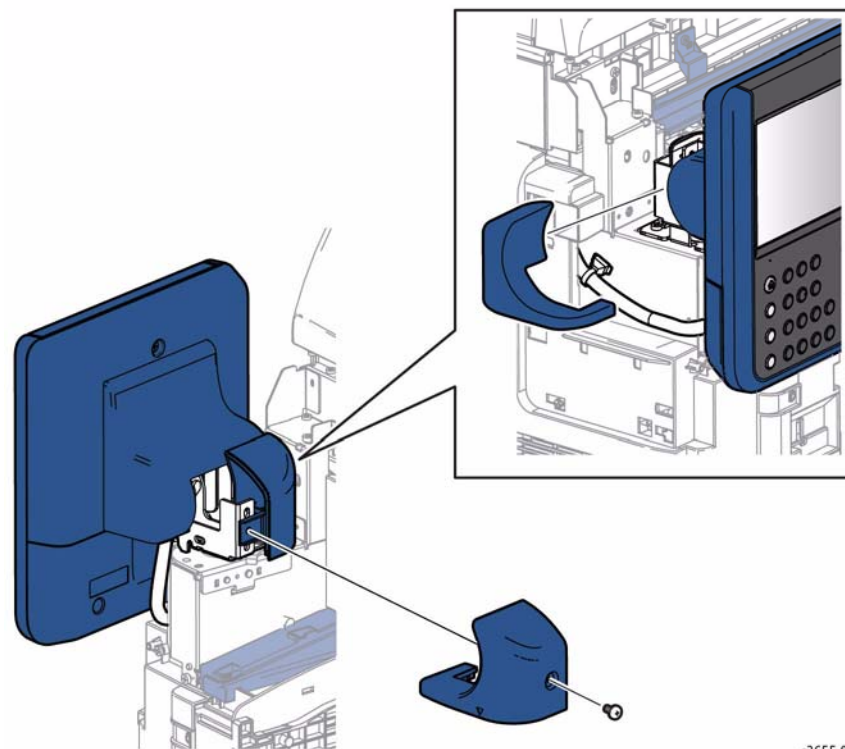

Figure 1 Remove the UI Hinge Cover

s3655-010

REP 1.2.9 UI Cable

Parts List on PL 1.2 Item 9

Removal

WARNING

Switch off the electricity to the machine. Disconnect the power cord from the customer supply while performing tasks that do not need electricity. Electricity can cause death or injury. Moving parts can cause injury.

CAUTION

The UI Cable connector is easily damaged. Use care when connecting, disconnecting, and routing the UI Cable through the UI Hinge Assembly.

1. Open the Rear Cover
2. Remove the Left Rear Cover, REP 19.2.2.
3. Open the Front Cover.
4. Remove the Left UI Base Cover, REP 1.1.6.
5. Remove the Left Side Cover, REP 19.2.1.
6. Remove the ESS housing cover, REP 18.1.1.
7. Disconnect the UI Cable from the ESS Board.
8. Remove the ESS housing, REP 18.1.2.
9. Refer to Figure 1 to locate and release the Control Panel cable from 3 clamps and 1 tie that secure the cable to the chassis and UI Hinge Assembly.

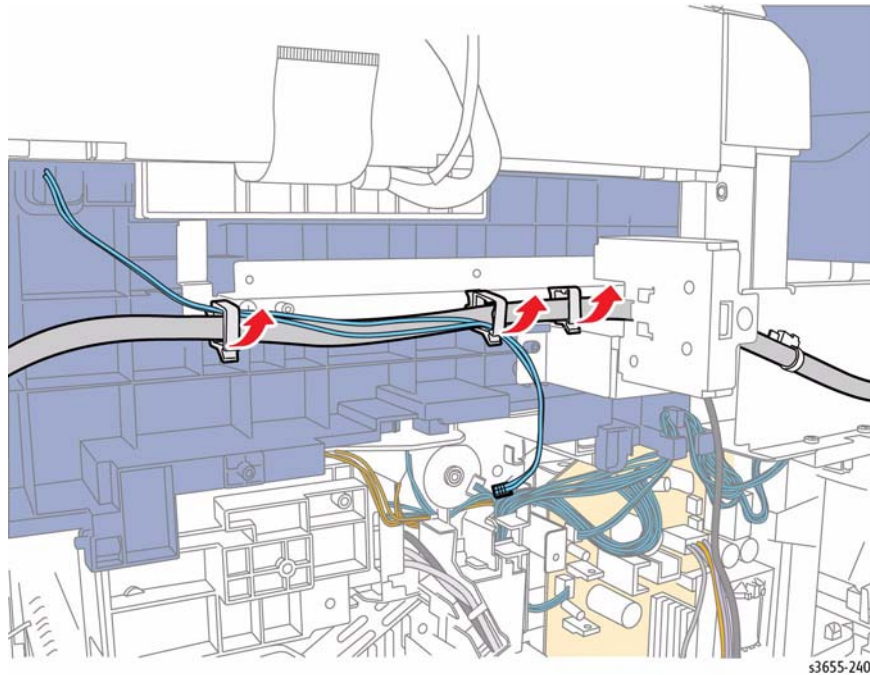

Figure 1 Release the Control Panel cable

10. Remove the UI Hinge Cover, REP 1.2.3.
11. Remove the Upper Rear UI Cover, REP 1.2.2.
12. Disconnect the UI cable from the Control Panel.
13. Refer to Figure 2 to locate and remove 1 screw and 1 tie that secure the cable to the Control Panel, then remove the cable from the UI Hinge Assembly.

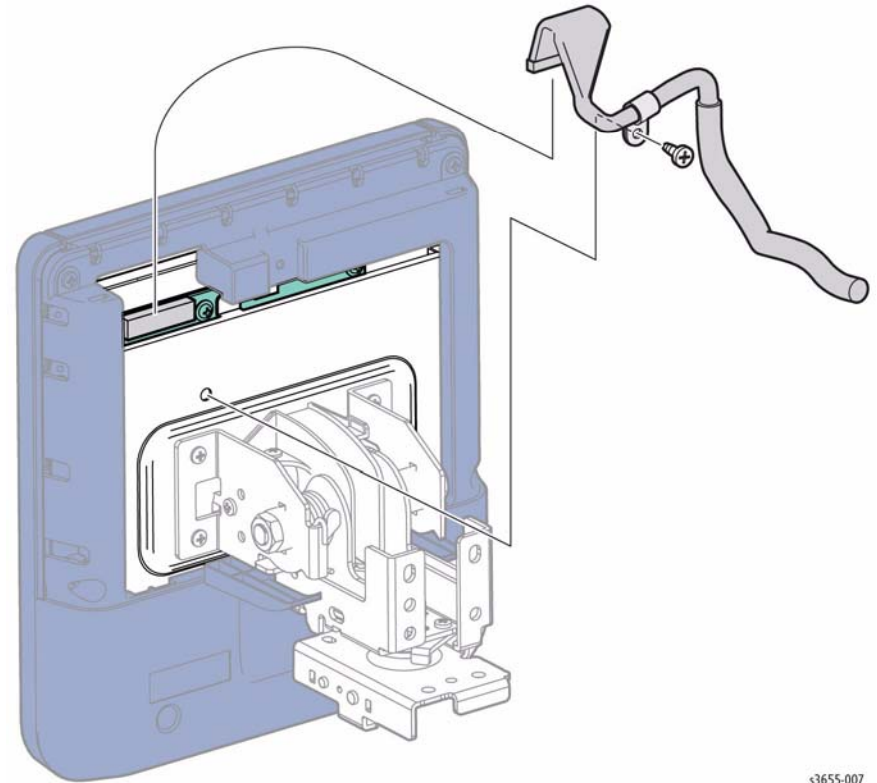

Figure 2 Disconnect the UI Cable

s3655-007

REP 1.2.98 UI Hinge Assembly

Parts List on PL 1.2 Item 98

Removal

WARNING

Switch off the electricity to the machine. Disconnect the power cord from the customer supply while performing tasks that do not need electricity. Electricity can cause death or injury. Moving parts can cause injury.

CAUTION

The UI Cable connector is easily damaged. Use care when connecting, disconnecting, and routing the UI Cable through the UI Hinge Assembly.

1. Remove the UI Hinge Cover, REP 1.2.2.
2. Remove the IIT Top Cover, REP 1.1.1.
3. Remove the IIT Front Cover, REP 1.1.2.
4. Open the Front Cover.
5. Remove the Left UI Base Cover, REP 1.1.6.
6. Remove the Right UI Base Cover, REP 1.1.4.
7. Remove the Upper Rear UI Cover, REP 1.2.2.
8. Remove the Control Panel, REP 1.2.1.
9. Remove the UI cable from the UI Hinge Assembly.
10. Refer to Figure 1 to locate and remove 1 screw (silver, M3, 6mm) that secures the UI swivel stop.

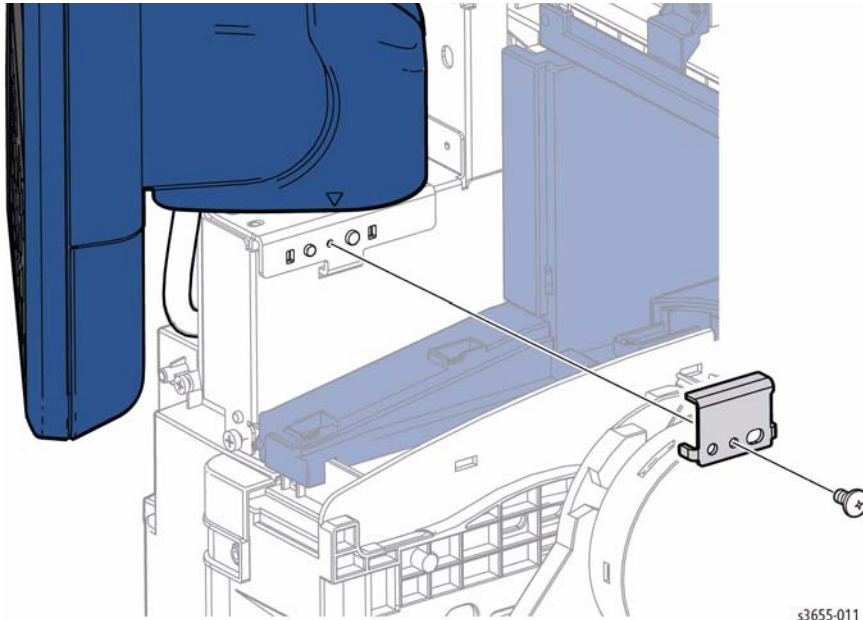

Figure 1 Remove the UI Swivel Stop

11. Refer to Figure 2 to locate and remove 3 screws (silver, M4, 6mm) that secure the UI Hinge Assembly to the chassis.

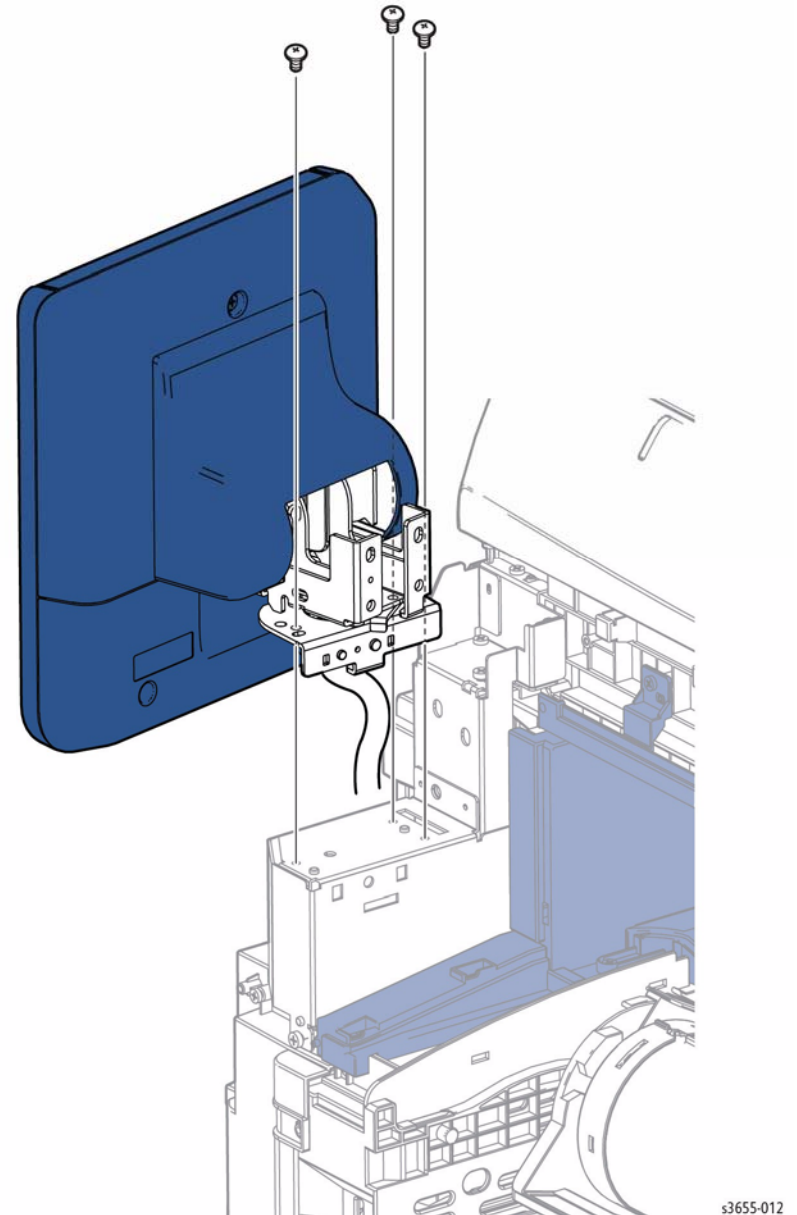

Figure 2 Remove the UI and Hinge Assembly

REP 2.1.1 Laser Unit

Parts List on PL 2.1 Item 1

Removal

WARNING

Switch off the electricity to the machine. Disconnect the power cord from the customer supply while performing tasks that do not need electricity. Electricity can cause death or injury. Moving parts can cause injury.

CAUTION

Cover the Drum Cartridge after removal to prevent light exposure.

1. Remove the Bypass Tray, REP 13.2.9.
2. Remove the Front Cover Assembly, REP 19.1.96.

NOTE: Fully extend the Front Links forward to remove the Drum Cartridge.

3. Remove the Drum Cartridge, REP 8.1.1.
4. Refer to Figure 1 to locate and release 3 hooks that secure the MCU Board cover. Remove the cover then disconnect all MCB Board connections except PJ11 and 26.

NOTE: Do not remove the MCU Board.

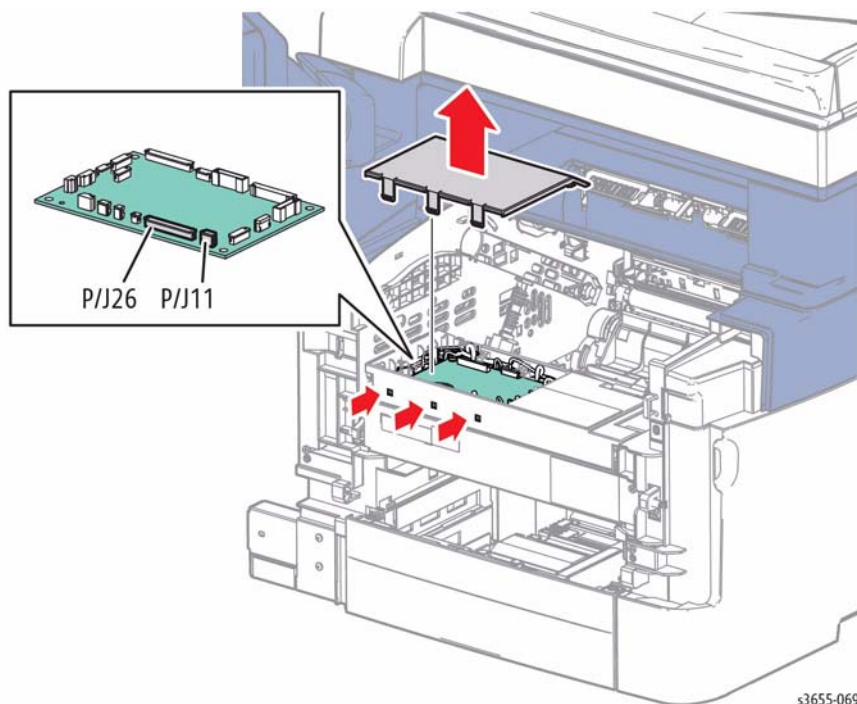

Figure 1 Disconnect the MCU Board

5. Refer to Figure 2 to locate and remove 2 screws (silver, M3, 6mm) that secure the MCU housing to the chassis.

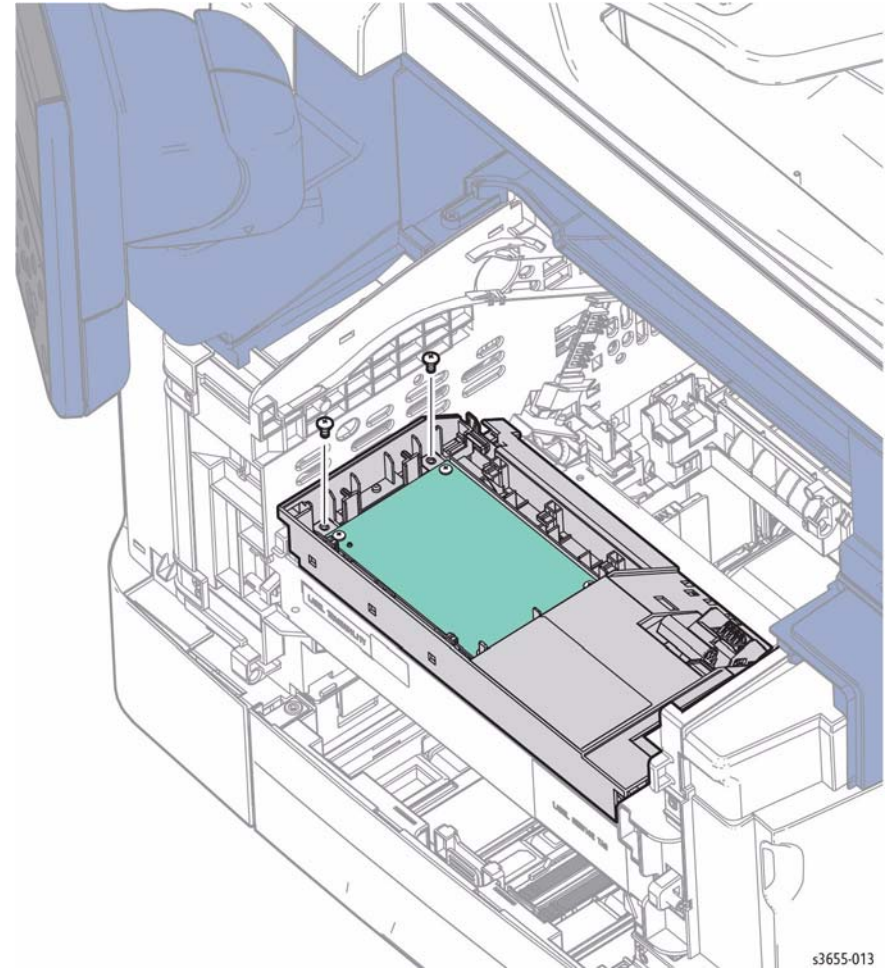

Figure 2 Release the MCU Housing

6. Disconnect the Toner CRUM and release the Toner CRUM harness from the MCU housing cover.
7. Remove the harnesses from the MCU housing harness guides to provide enough slack to move the MCU housing to the front of the printer.
8. Refer to Figure 3 to locate and release 1 hook at the right side, rotate the housing forward, then lift the housing off of the pins and rest the housing at the front of the printer.

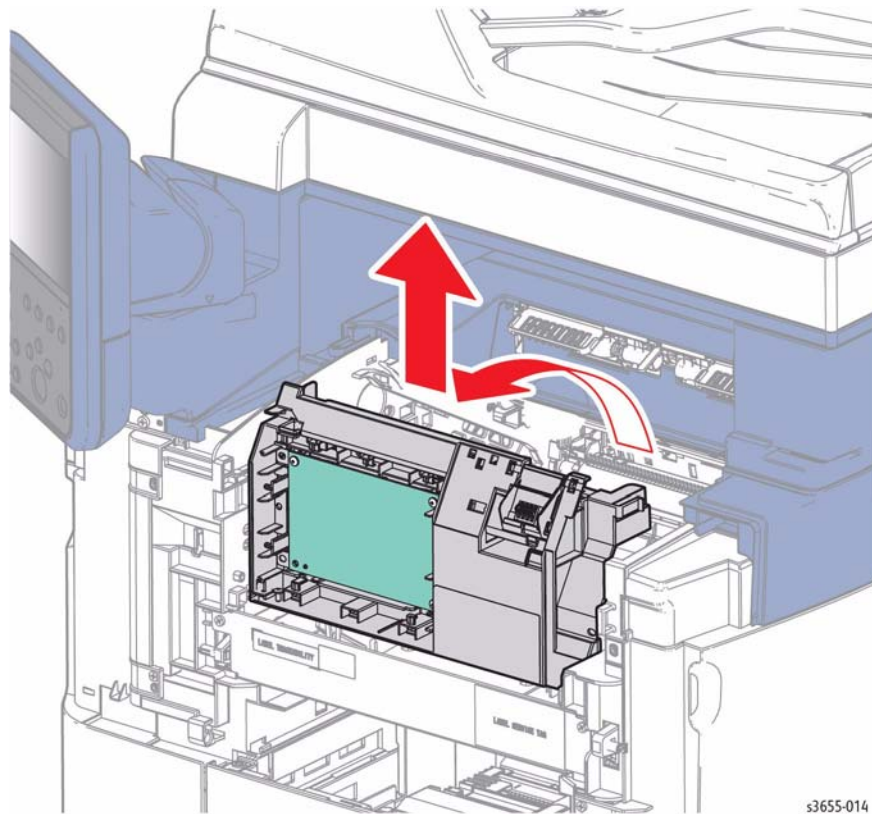

Figure 3 Rotate the MCU Housing

s3655-014

9. Refer to Figure 4 to locate and remove 4 screws (silver, flanged, tapping, 10mm), disconnect the Laser Unit and lift to remove .

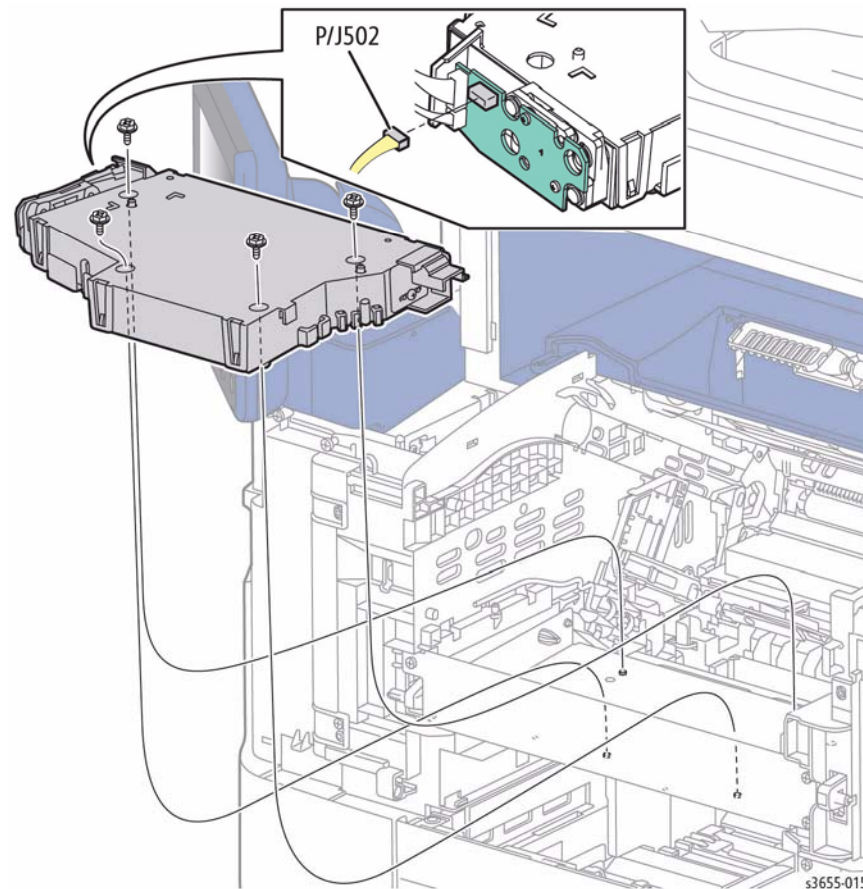

Figure 4 Remove the Laser Unit

s3655-015

REP 3.1.1 Main Drive Assembly

Parts List on PL 3.1 Item 1

Removal

WARNING

Switch off the electricity to the machine. Disconnect the power cord from the customer supply while performing tasks that do not need electricity. Electricity can cause death or injury. Moving parts can cause injury.

WARNING

Do not touch the Fuser while it is hot.

1. Open the Rear Cover.
2. Remove the Fuser, REP 7.1.1.
3. Remove the Left Rear Cover, REP 19.2.2.
4. Open the Front Cover.
5. Remove the Left UI Base Cover, REP 1.1.6.
6. Remove the Left Side Cover, REP 19.2.1.
7. Remove the ESS housing cover, REP 18.1.1.
8. Remove the ESS housing, REP 18.1.2.
9. Push the Front Link all the way into the chassis.
10. Refer to Figure 1 to locate and remove 2 screws (silver, tapping, 8mm and metal 8 mm) that secure the main drive bracket.
11. Refer to Figure 1 to locate and remove 4 screws (silver, tapping, 8mm) and disconnect the Main Drive Assembly to remove.

NOTE: Fully retract the right link shaft to disengage the Main Drive Assembly gears.

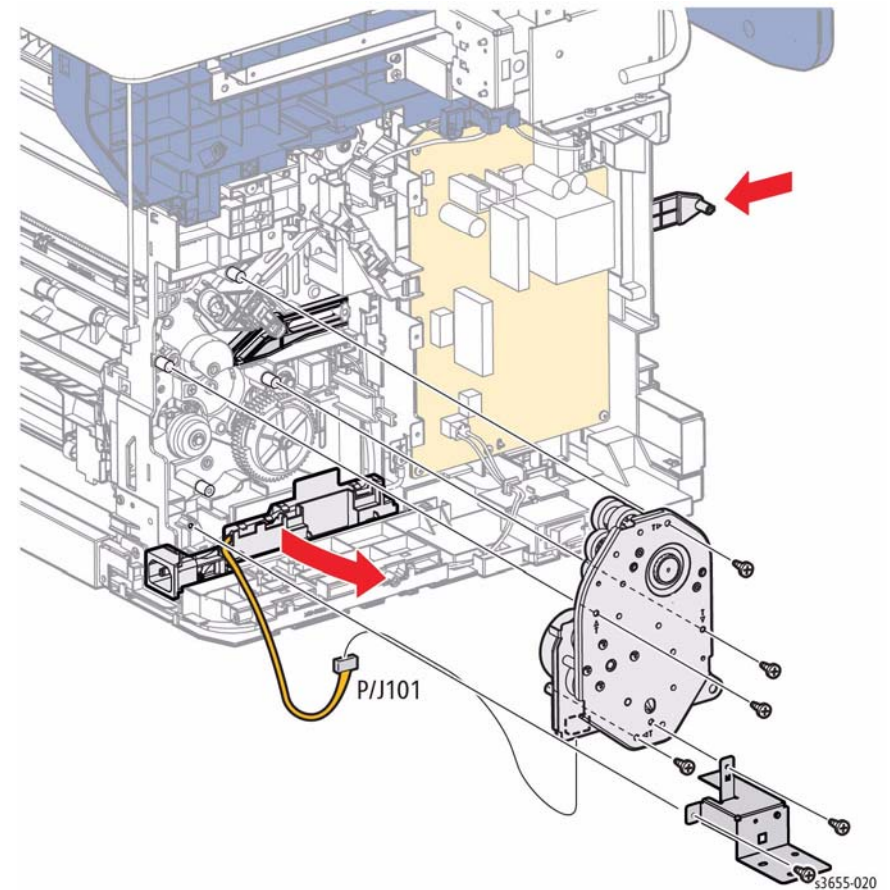

Figure 1 Remove the Main Drive Assembly

REP 3.1.2 Exit Drive Assembly

Parts List on PL 3.1 Item 2

Removal

WARNING

Switch off the electricity to the machine. Disconnect the power cord from the customer supply while performing tasks that do not need electricity. Electricity can cause death or injury. Moving parts can cause injury.

WARNING

Do not touch the Fuser while it is hot.

CAUTION

Cover the Drum Cartridge after removal to prevent light exposure.

1. Open the Rear Cover.
2. Remove the Fuser, REP 7.1.1.
3. Remove the Left Rear Cover, REP 19.2.2.
4. Open the Front Cover.
5. Remove the Drum Cartridge, REP 8.1.1.
6. Remove the Left UI Base Cover, REP 1.1.6.
7. Remove the Left Side Cover, REP 19.2.1.
8. Remove the ESS housing cover, REP 18.1.1.
9. Remove the ESS housing, REP 18.1.2.

NOTE: Carefully compress the Fuser connector clips to release.

10. Refer to Figure 1 to locate and release 2 clips that secure the Fuser harness.

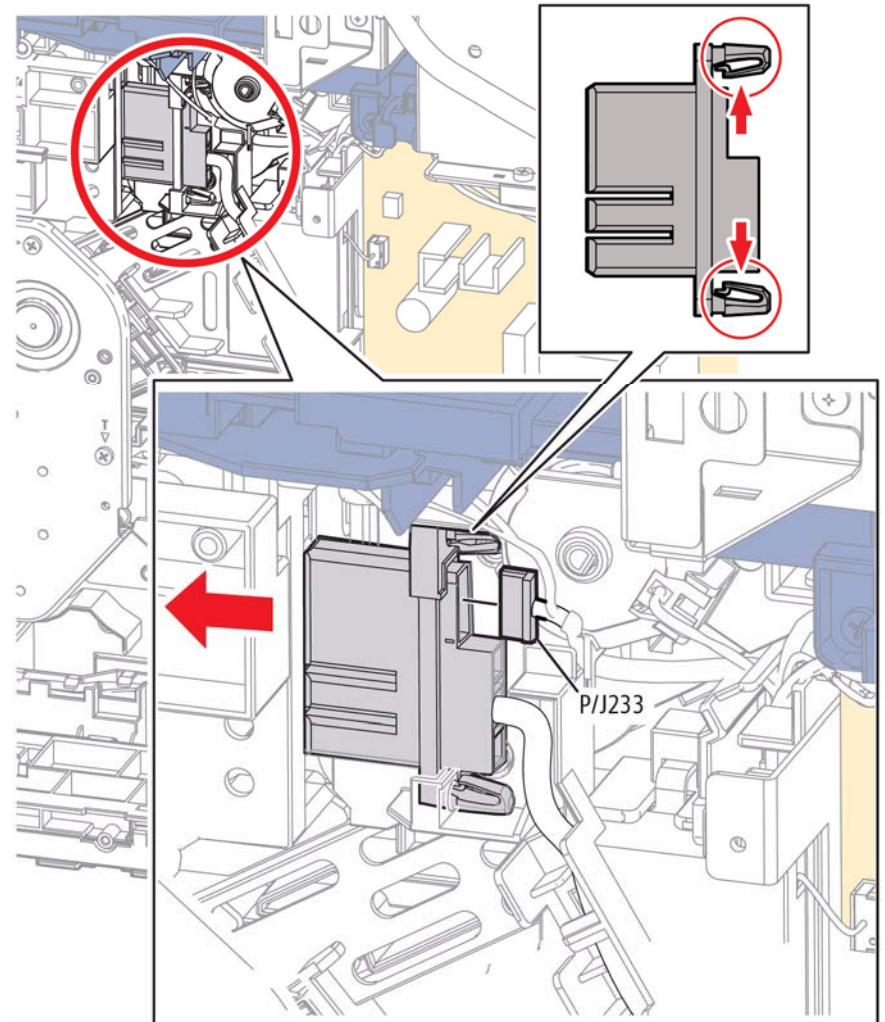

Figure 1 Release the Fuser Harness

11. Refer to Figure 2 to locate and release 4 hooks that secure the Top Frame Assembly to remove it from the chassis.

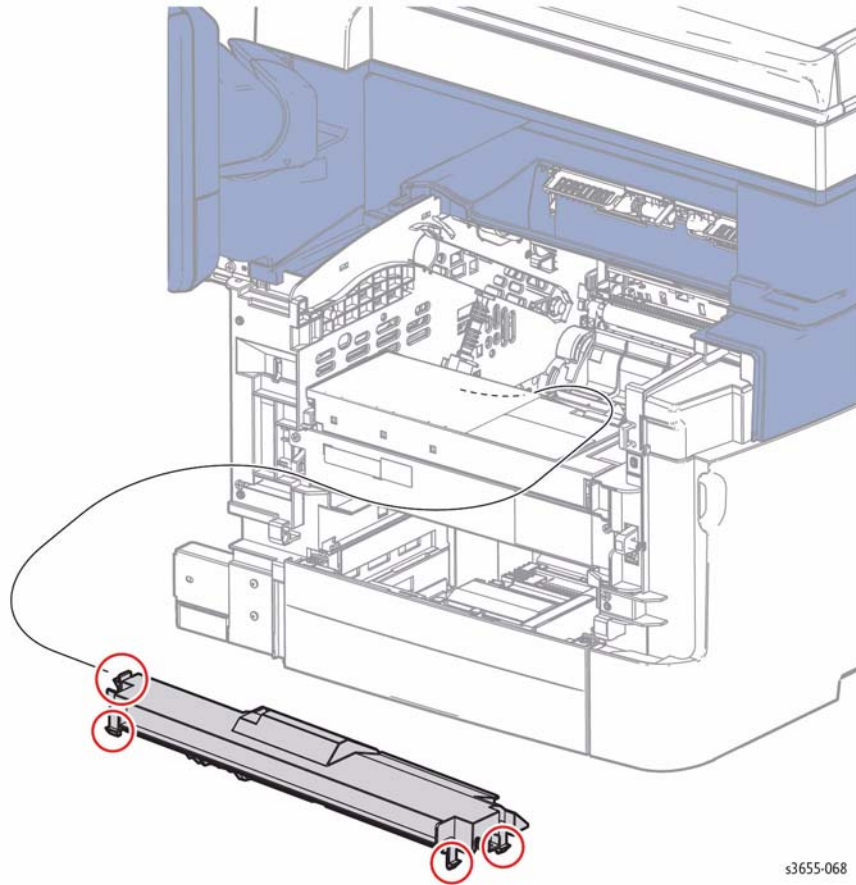

Figure 2 Remove the Top Frame Assembly

12. Refer to Figure 3 to locate and release 3 hooks that secure the MCU Board cover to remove it from the chassis.
13. Disconnect the Exit Drive Assembly from the MCU Board and release the exit clutch harness from the guides on both sides of the chassis.

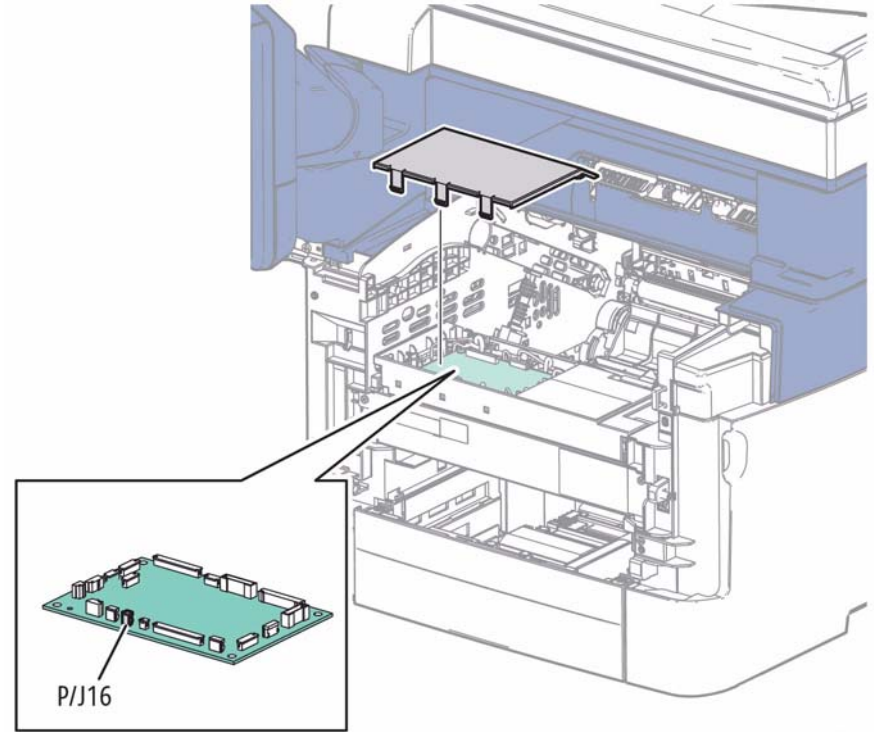

Figure 3 Disconnect the Exit Drive Assembly

14. Refer to Figure 4 to locate and remove 2 screws (silver, tapping, 8mm) and release 1 hook that secures the Exit Drive Assembly.

NOTE: Gears are not captive in the assembly.

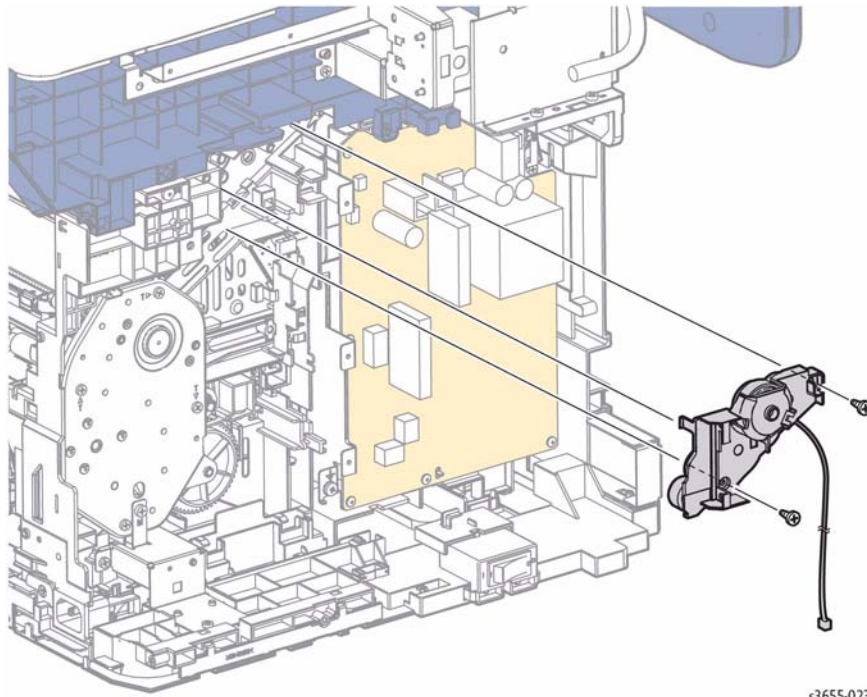

Figure 4 Remove the Exit Drive Assembly

s3655-023

Replacement

1. Figure 5 shows gear placement in the Exit Drive Assembly.

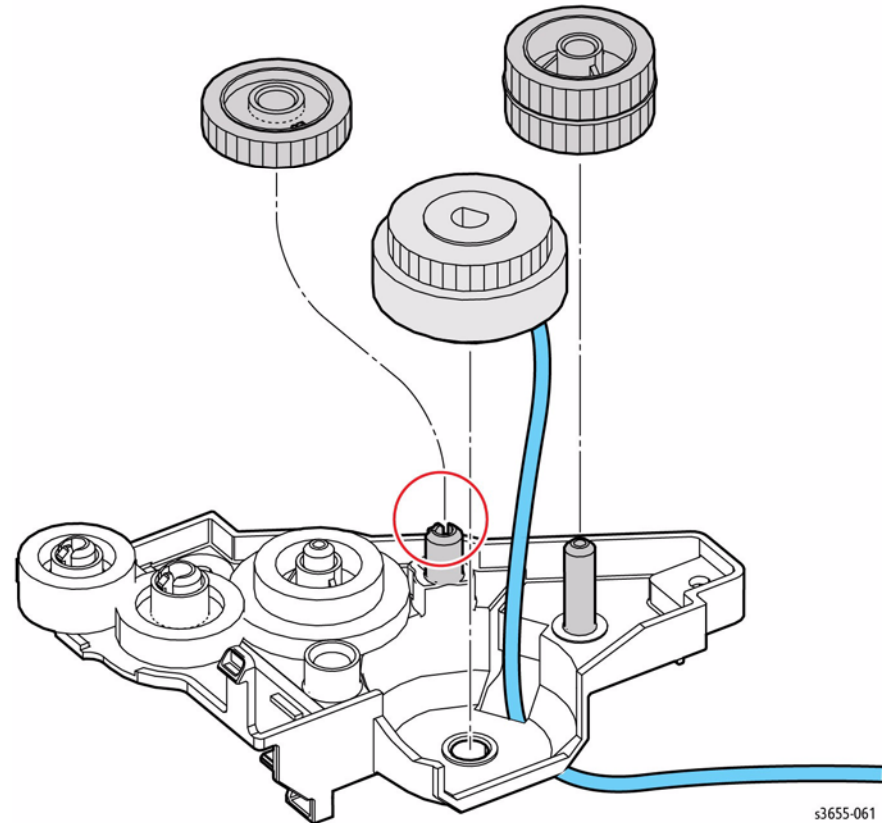

Figure 5 Assemble the Exit Drive Assembly

s3655-061

2. Refer to Figure 6 to locate and fit the D-shaped shaft of the Exit Invert Drive Assembly into the D-shaped hole of the exit clutch.

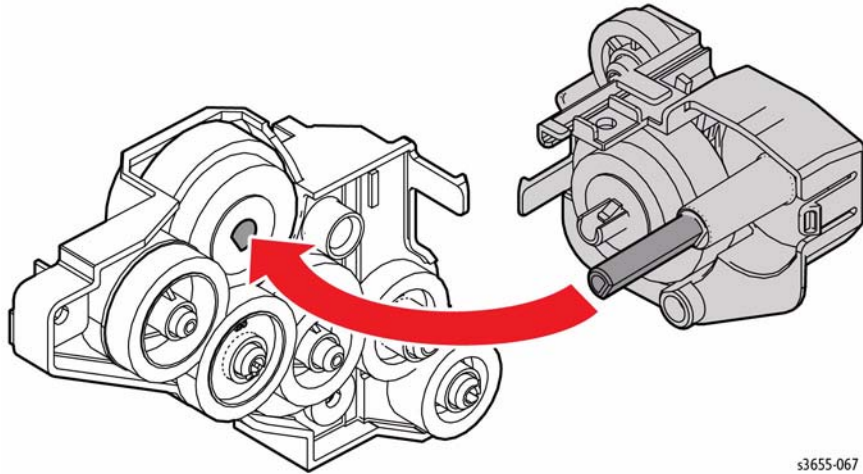

Figure 6 Engage the Shaft with the Clutch

s3655-067

3. Refer to Figure 7 when installing the Top Frame Assembly. Align the Bypass Tray No Paper Sensor Actuator coupled with the Top Frame Assembly so it fits into the hole on the printer and the MSI lock connects with the Pick Up Holder Assembly.

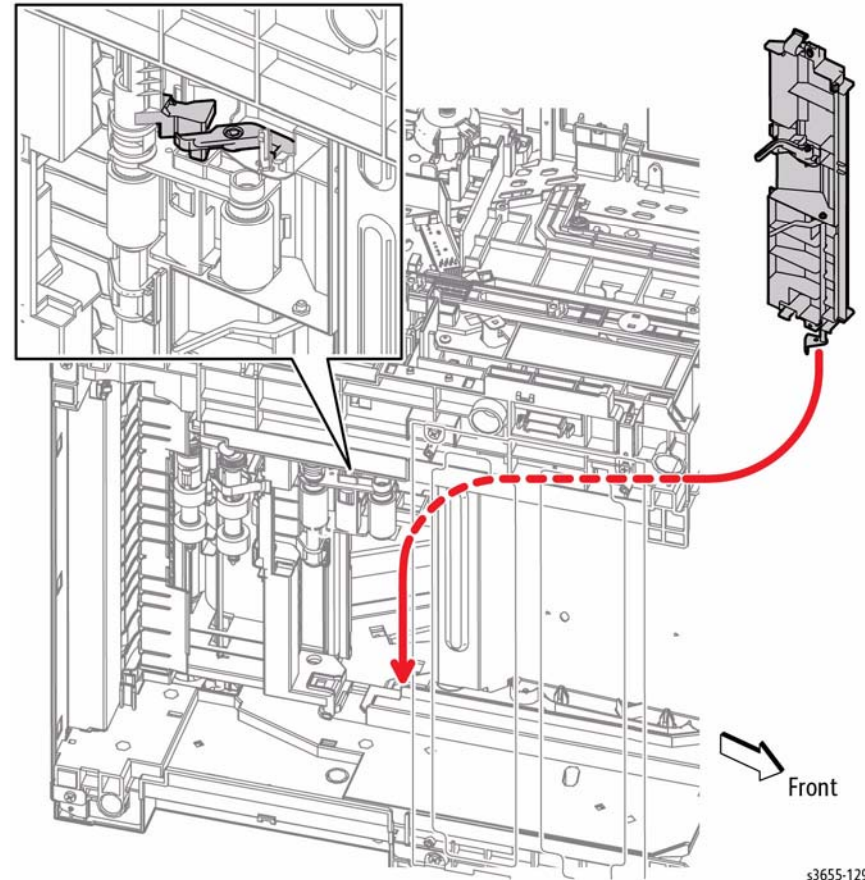

Figure 7 Install the Top Frame Assembly

s3655-129

REP 3.1.3 Exit Invert Drive Assembly

Parts List on PL 3.1 Item 3

Removal

WARNING

Switch off the electricity to the machine. Disconnect the power cord from the customer supply while performing tasks that do not need electricity. Electricity can cause death or injury. Moving parts can cause injury.

WARNING

Do not touch the Fuser while it is hot.

CAUTION

Cover the Drum Cartridge after removal to prevent light exposure.

1. Open the Rear Cover.
2. Remove the Fuser, REP 7.1.1.
3. Remove the Left Rear Cover, REP 19.2.2.
4. Open the Front Cover.
5. Remove the Drum Cartridge, REP 8.1.1.
6. Remove the Left UI Base Cover, REP 1.1.6.
7. Remove the Left Side Cover, REP 19.2.1.
8. Remove the ESS housing cover, REP 18.1.1.
9. Remove the ESS housing, REP 18.1.2.
10. Refer to Figure 1 to locate and release 2 clips that secure the Fuser harness.

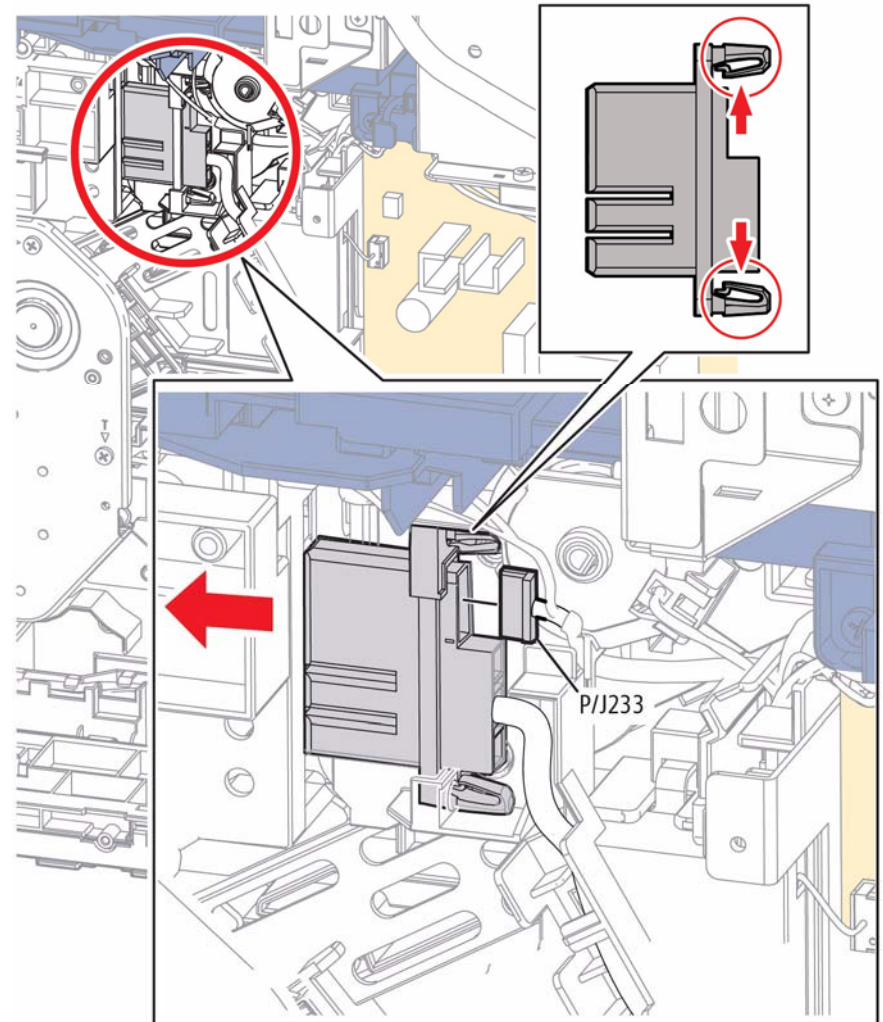

Figure 1 Release the Fuser Harness

11. Remove the Stapler Cover, REP 19.1.11 or Outer Right Cover, REP 19.1.13.
12. Remove the Right Side Cover, REP 19.1.10.
13. Remove the Right Inner Cover, REP 19.1.14.
14. Remove the Exit Cover Assembly, REP 19.2.99.
15. Refer to Figure 2 to locate and release 4 hooks that secure the Top Frame Assembly to remove it from the chassis.

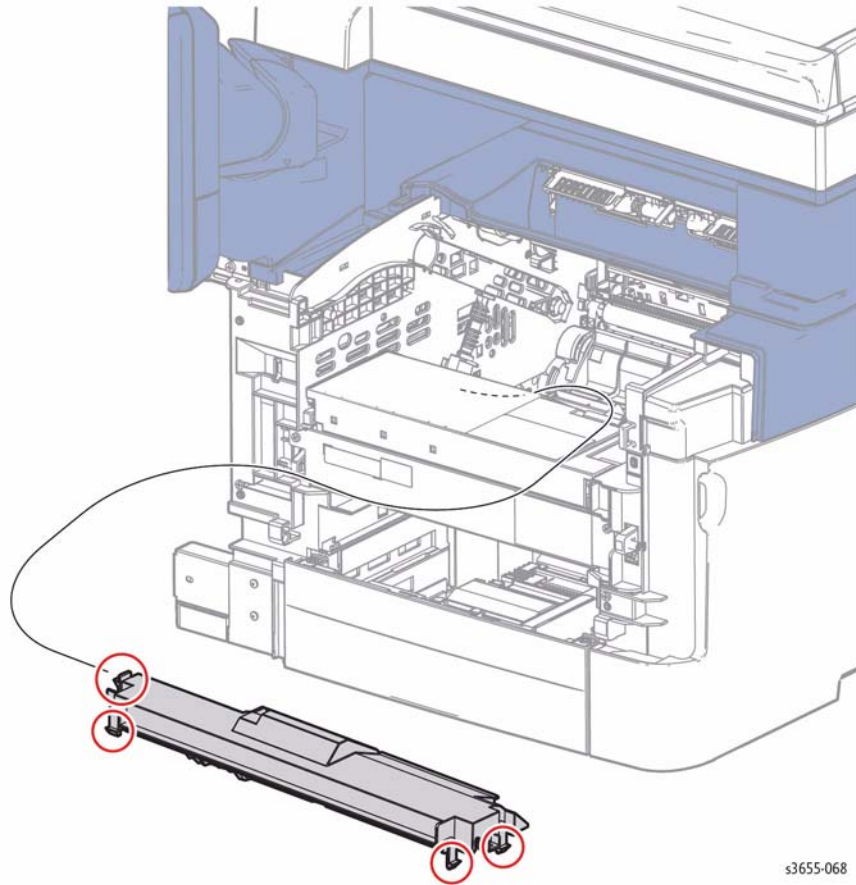

Figure 2 Remove the Top Frame Assembly

s3655-068

16. Refer to Figure 3 to locate and release 3 hooks that secure the MCU Board cover to remove it from the chassis.
17. Disconnect the Exit Invert Drive Assembly from the MCU Board and release the invert clutch harness from the guides on both sides of the chassis.

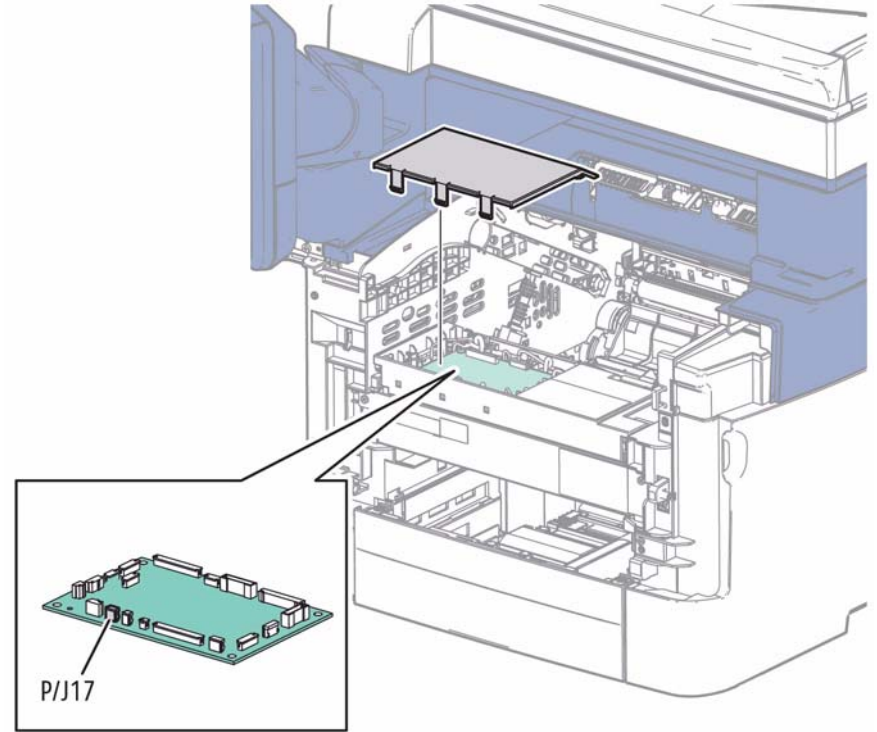
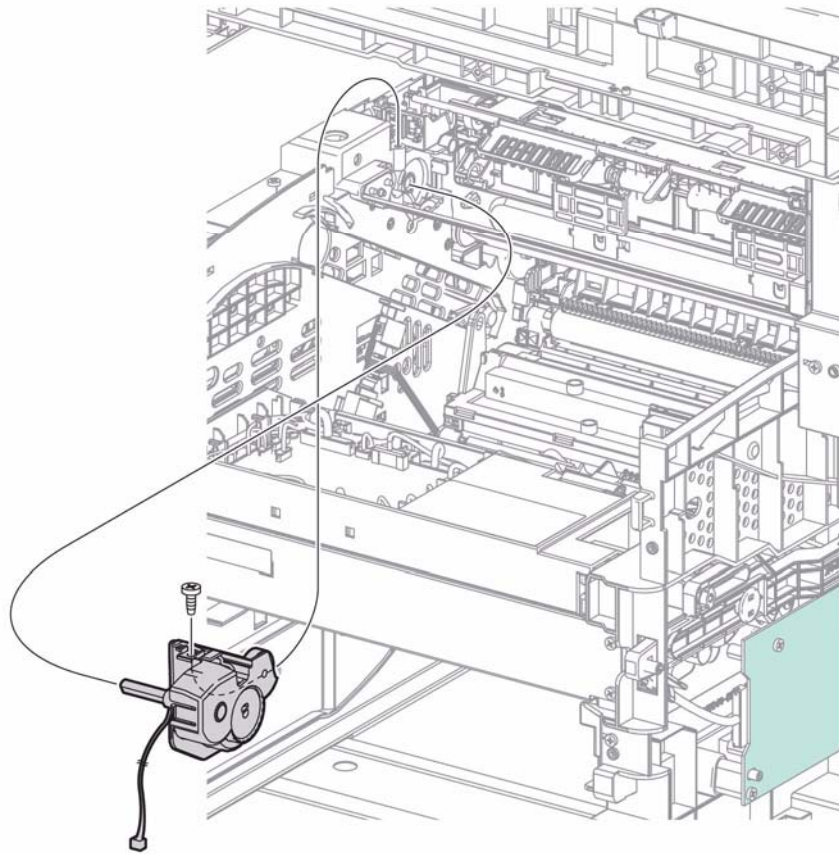

Figure 3 Disconnect the Exit Invert Drive Assembly

s3655-249

18. Refer to Figure 4 to locate and remove 1 screw (silver, tapping, 8mm) and 2 hooks that secure the Exit Invert Drive Assembly.



s3655-119

Figure 4 Remove the Exit Invert Drive Assembly

Replacement

1. Refer to Figure 5 when installing the Exit Invert Drive Assembly. Fit the D-shaped shaft of the Exit Invert Drive Assembly into the D-shaped hole of the exit clutch.

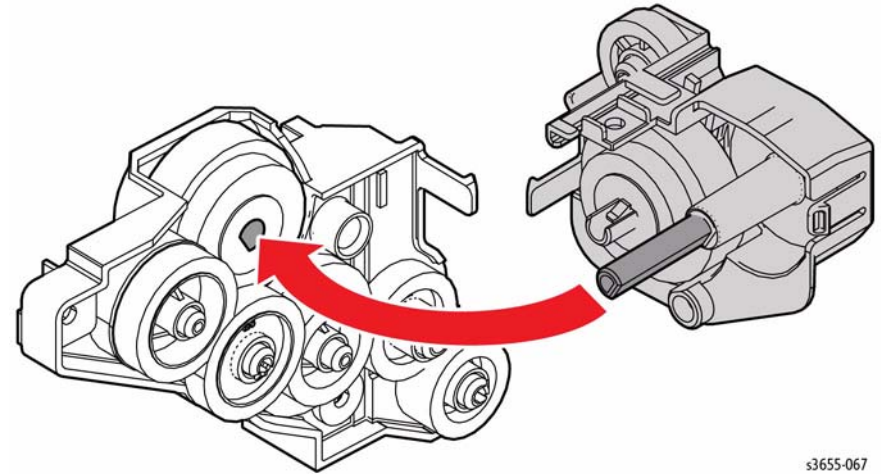

s3655-067

Figure 5 Engage the Exit Clutch

2. Refer to Figure 6 when installing the Top Frame Assembly. Align the Bypass Tray No Paper Sensor Actuator coupled with the Top Frame Assembly so it fits into the hole on the printer and the Lock MSI In connects with the Pick Up Holder Assembly.

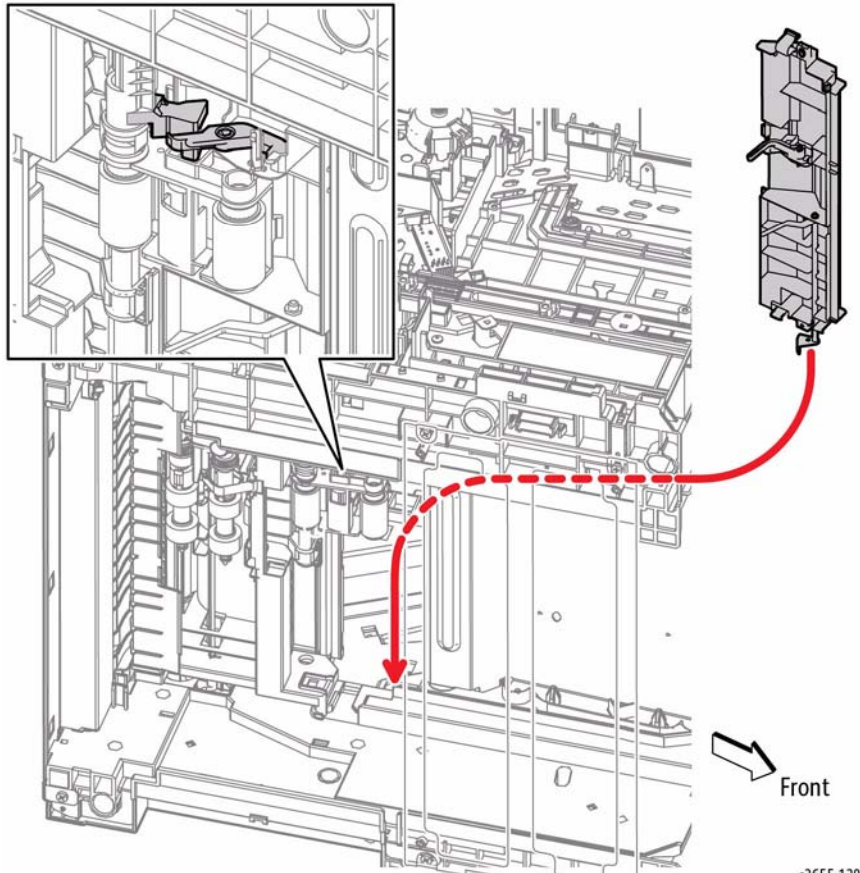

Figure 6 Install the Top Frame Assembly

REP 3.1.4 Duplex Gear and Holder

Parts List on PL 3.1 Item 4, PL 3.1 Item 5

Removal

WARNING

Switch off the electricity to the machine. Disconnect the power cord from the customer supply while performing tasks that do not need electricity. Electricity can cause death or injury. Moving parts can cause injury.

WARNING

Do not touch the Fuser while it is hot.

1. Open the Rear Cover.
2. Refer to Figure 1 to locate and rotate the Gear Holder clockwise while pulling the tab to remove the holder and gear.

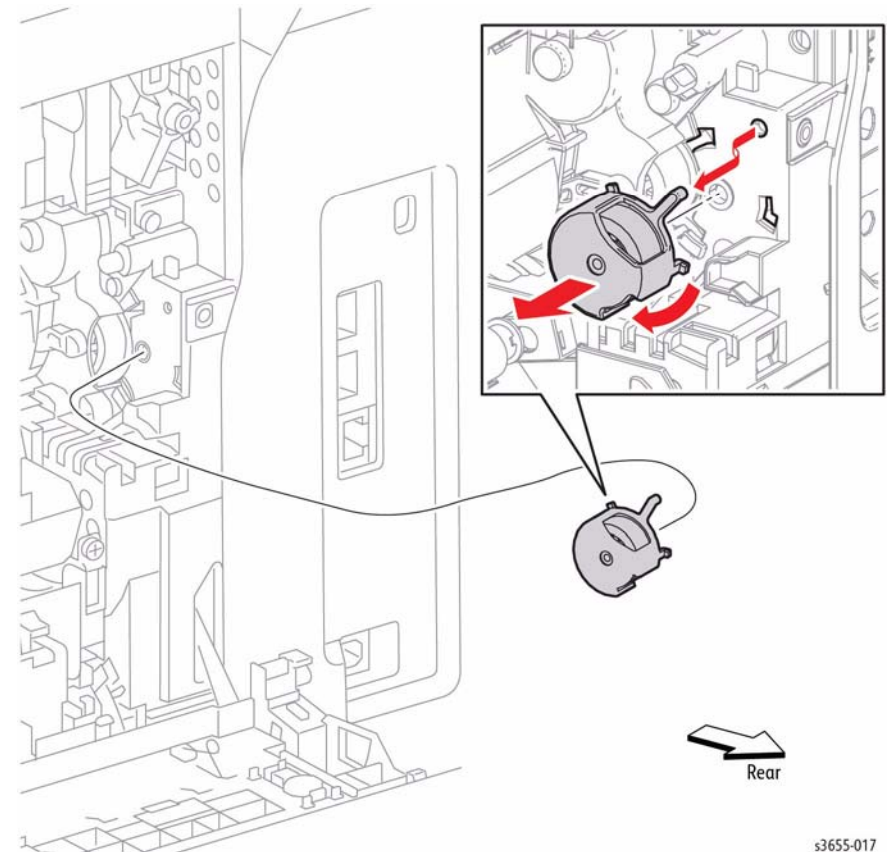

Figure 1 Remove the Duplex Gear and Holder

REP 4.1.1 LVPS Fan

Parts List on PL 4.1 Item 1

Removal

WARNING

Switch off the electricity to the machine. Disconnect the power cord from the customer supply while performing tasks that do not need electricity. Electricity can cause death or injury. Moving parts can cause injury.

WARNING

Do not touch the Fuser while it is hot.

CAUTION

The LVPS Fan is connected to the chassis. Use care when removing the Left Side Cover not to damage the LVPS Fan harness.

1. Open the Rear Cover
2. Remove the Left Rear Cover, REP 19.2.2.
3. Open the Front Cover.
4. Remove the Left UI Base Cover, REP 1.1.6.
5. Remove the Left Side Cover, REP 19.2.1.
6. Refer to Figure 2 to locate and release 1 cable tie and disconnect the fan from the chassis.

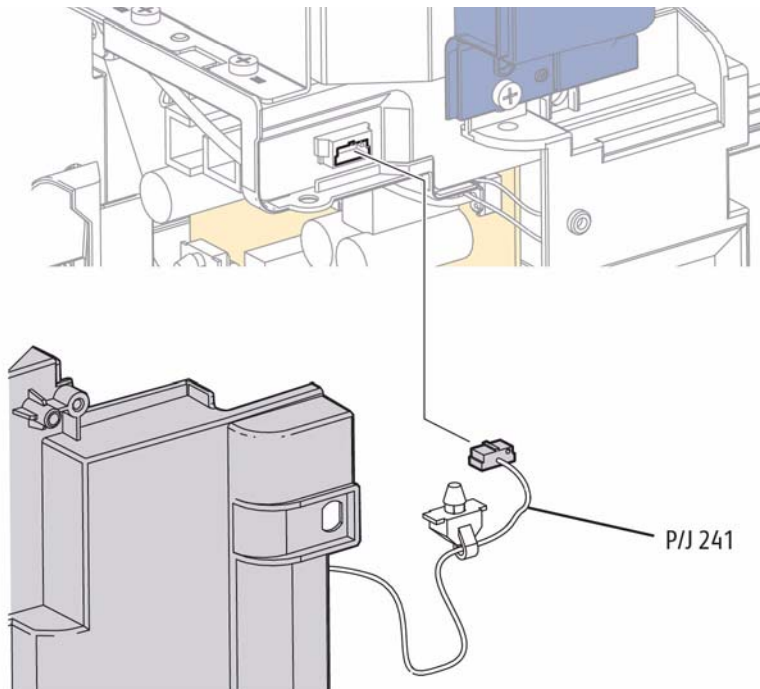

Figure 1 Disconnect the LVPS Fan

s3655-110

7. Refer to Figure 2 to locate and remove 2 screws (silver, tapping, M3, 22mm) and disconnect 1 cable tie to remove the fan from the Left Side Cover.

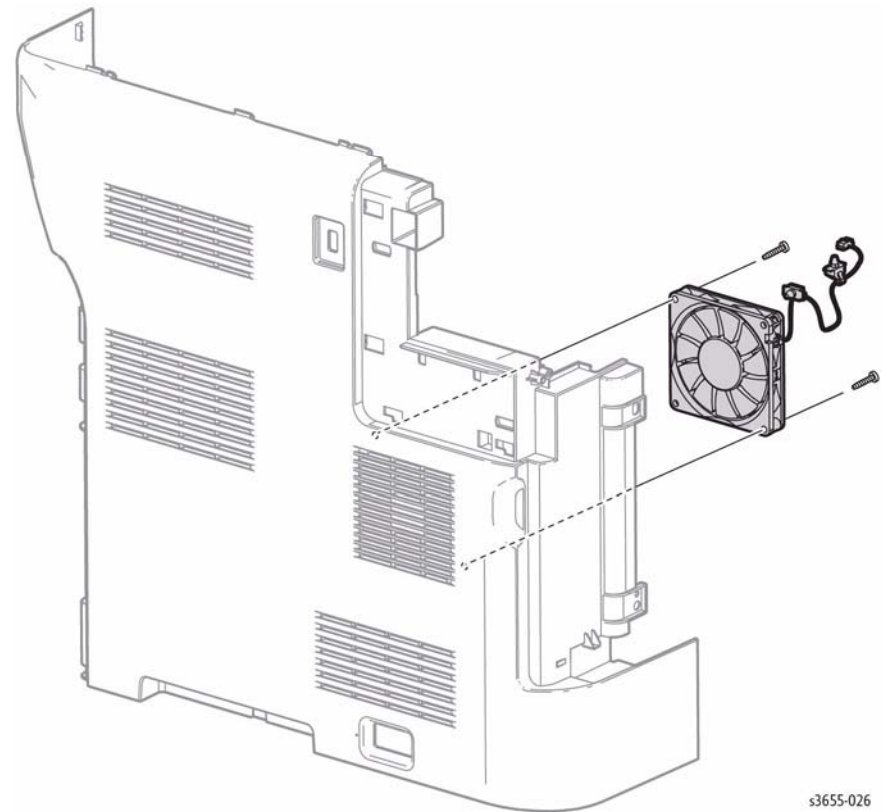

Figure 2 Remove the LVPS Fan

s3655-026

REP 4.1.3 Front Links

Parts List on PL 4.1 Item 3, PL 4.1 Item 4

Removal

WARNING

Switch off the electricity to the machine. Disconnect the power cord from the customer supply while performing tasks that do not need electricity. Electricity can cause death or injury. Moving parts can cause injury.

WARNING

Do not touch the Fuser while it is hot.

1. Open the Front Cover.
2. Release the right or left Front Link from the Front Cover Assembly.
3. Refer to Figure 1 to locate and release the Link Connector clips from the link shaft to remove the Front Link.

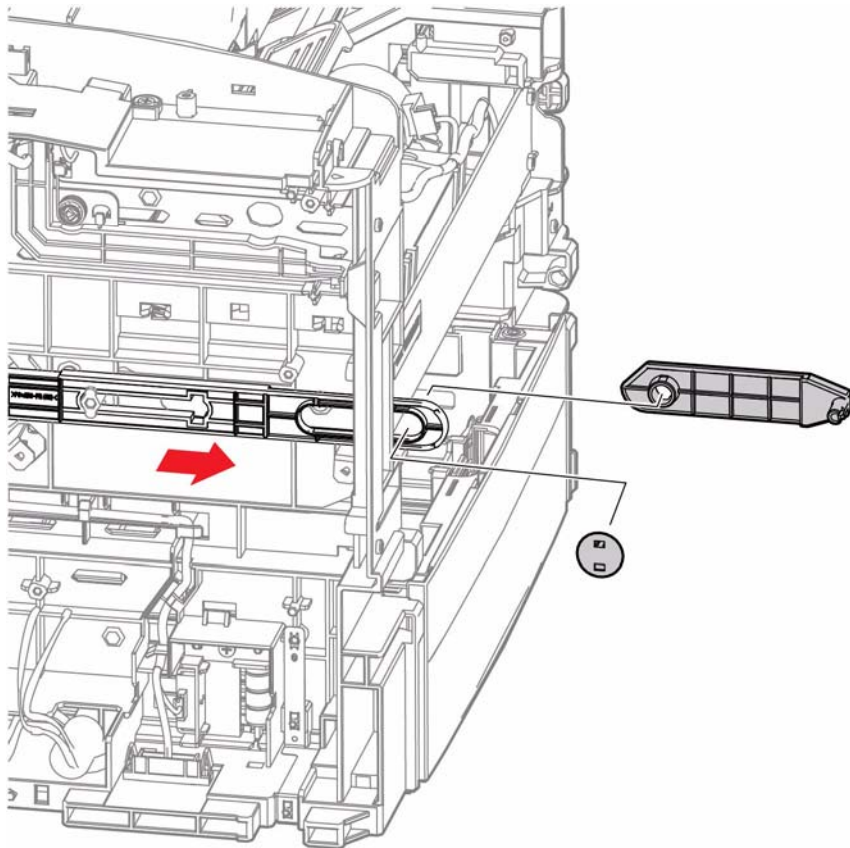

Figure 1 Remove the Front Link

s3655-024

REP 5.1.5 Dispense Drive Assembly

Parts List on PL 5.1 Item 5

Removal

WARNING

Switch off the electricity to the machine. Disconnect the power cord from the customer supply while performing tasks that do not need electricity. Electricity can cause death or injury. Moving parts can cause injury.

WARNING

Do not touch the Fuser while it is hot.

NOTE: Be prepared to support the IIT Assembly with the Inner Right Cover or something similar following IIT support removal.

1. Open the Front Cover.
2. Open the Rear Cover.
3. Remove the Stapler Cover, REP 19.1.11 or Outer Right Cover, REP 19.1.13.
4. Remove the Right Side Cover, REP 19.1.10.
5. Disconnect the HVPS.
6. Remove the HVPS, REP 18.2.5.
7. Remove the Inner Right Cover, REP 19.1.14.
8. Disconnect PJ801 from the Stapler LVPS and release the harness from the guides.
9. Refer to Figure 1 to locate and remove 5 (silver, tapping, 8mm) and 3 (silver, tapping, 10mm) screws that secure the IIT support to the chassis.

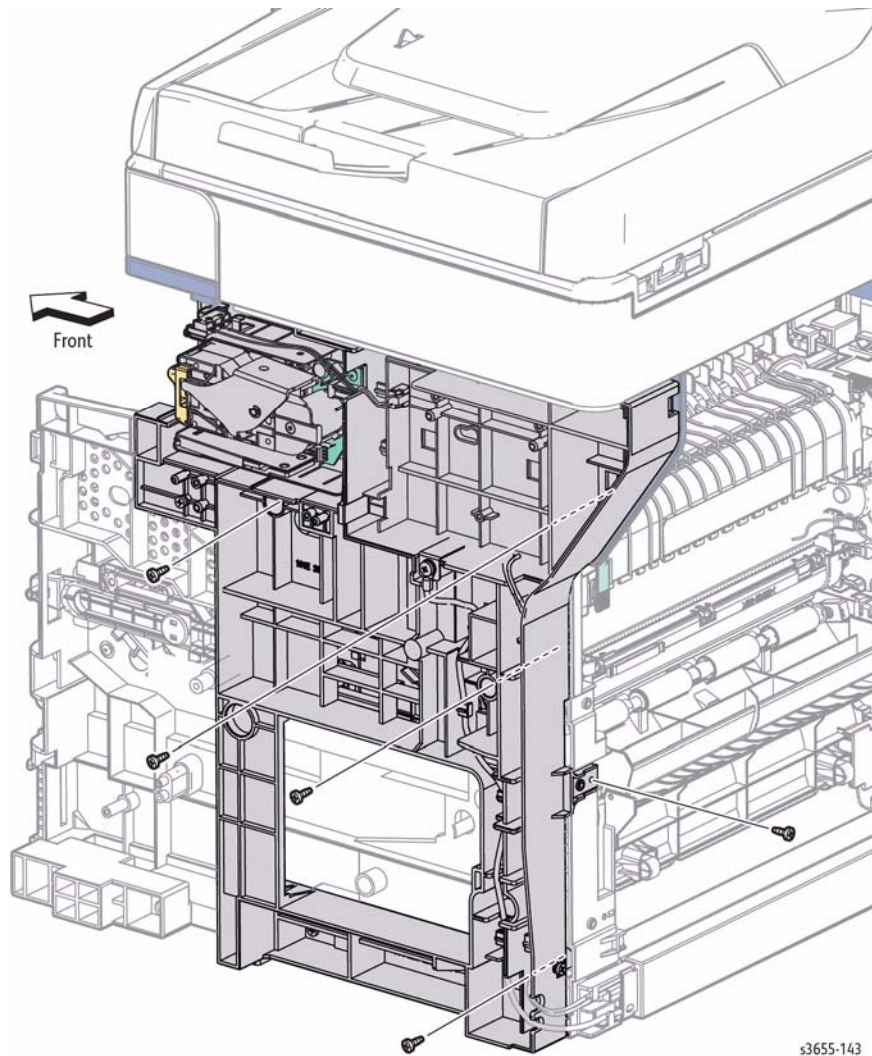

Figure 1 Remove the IIT Support screws

10. Refer to Figure 2 and slide the IIT support to the rear to release 1 boss while lifting the IIT Assembly to release the Scanner and SubLV Harness Guide. Lower the IIT support to the work surface. Use the Inner Right Cover or similar to support the IIT Assembly.

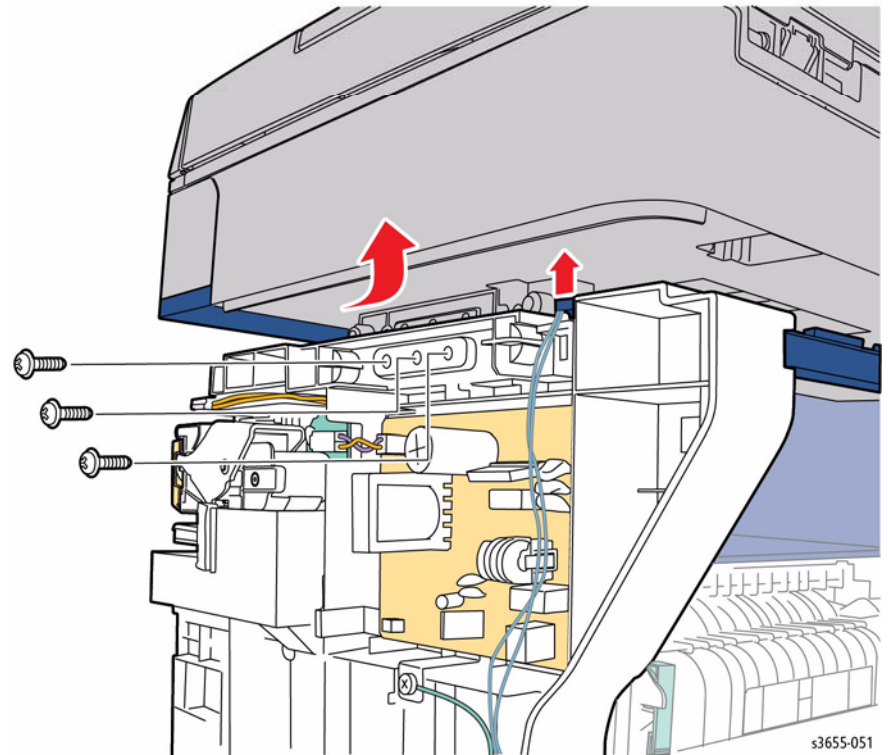

Figure 2 Remove the IIT screws

11. Lower the IIT support to the work surface. Use the Inner Right Cover resting on the Exit Cover Assembly or similar to support the IIT Assembly as shown in Figure 3.

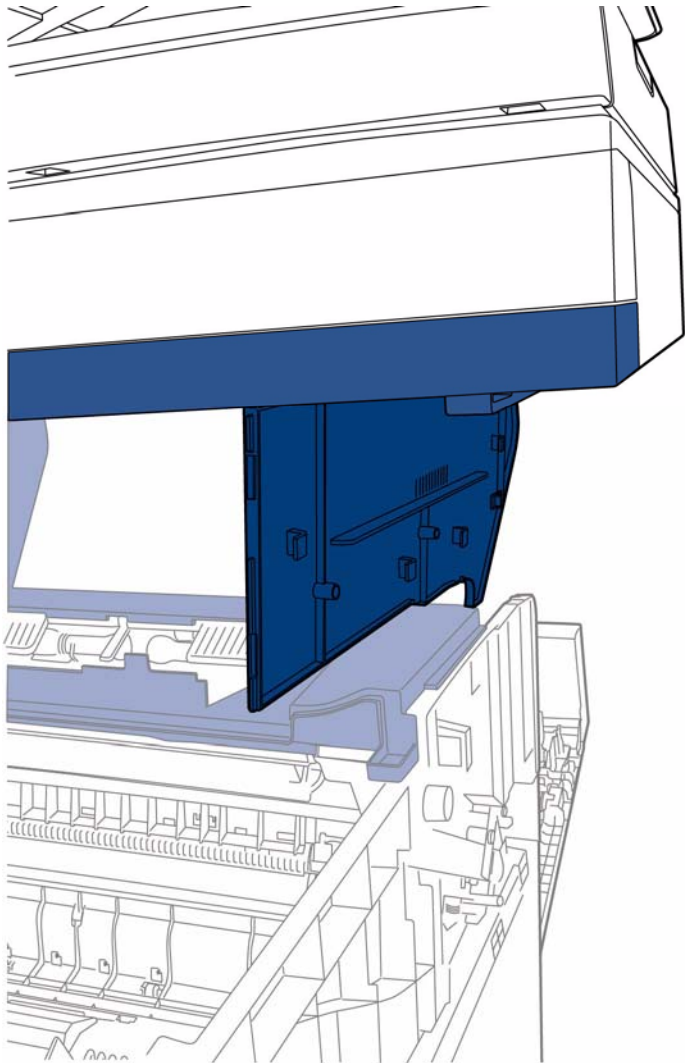
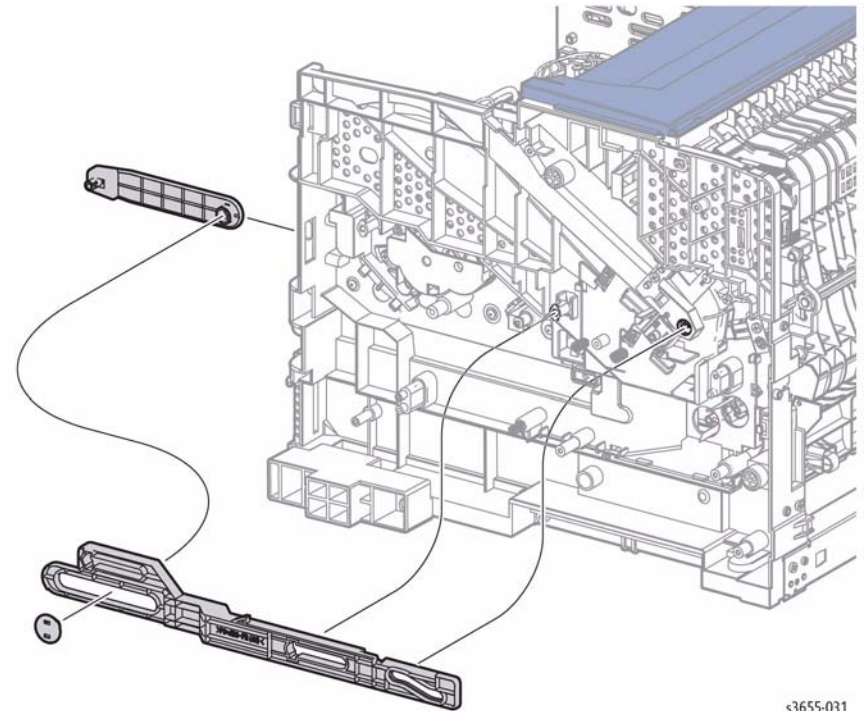

Figure 3 Support the IIT

12. Release the Link Connector clip from the Right Front Link and remove.
13. Refer to Figure 4 and release the right link shaft from the chassis clip.
14. Remove the right link shaft by gently flexing it away from the chassis.

s3655-053



s3655-031

Figure 4 Remove the Right Link Shaft

15. Refer to Figure 5 to locate and remove 2 screws (silver, tapping, 10mm) that secure the Dispense Drive Assembly to the chassis.

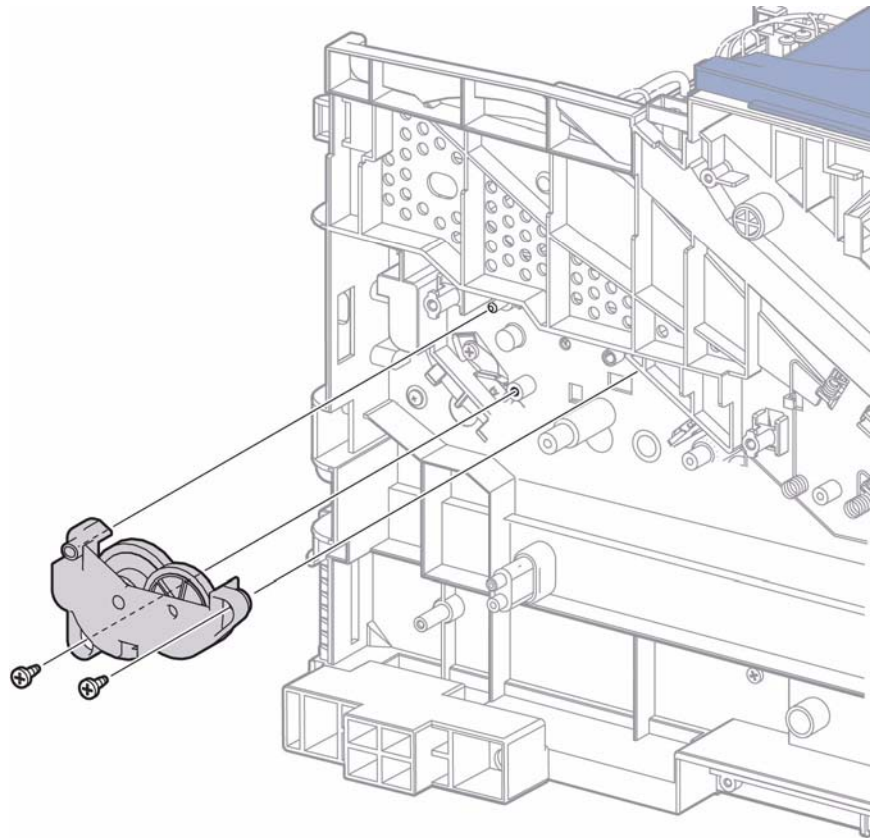

s3655-032

Figure 5 Remove the Dispense Drive Assembly

REP 5.1.9 Toner Dispense Motor

Parts List on PL 5.1 Item 9

Removal

WARNING

Switch off the electricity to the machine. Disconnect the power cord from the customer supply while performing tasks that do not need electricity. Electricity can cause death or injury. Moving parts can cause injury.

WARNING

Do not touch the Fuser while it is hot.

CAUTION

Cover the Drum Cartridge after removal to prevent light exposure.

1. Remove the Bypass Tray, REP 13.2.9.
2. Remove the Front Cover Assembly, REP 19.1.96.

NOTE: Fully extend the Front Links forward to remove the Drum Cartridge.

3. Remove the Drum Cartridge, REP 8.1.1.
4. Refer to Figure 1 to locate and release 3 hooks to remove the MCU Board Cover, then disconnect all MCU Board connections except PJ11,18 and 26. Do not remove the board.

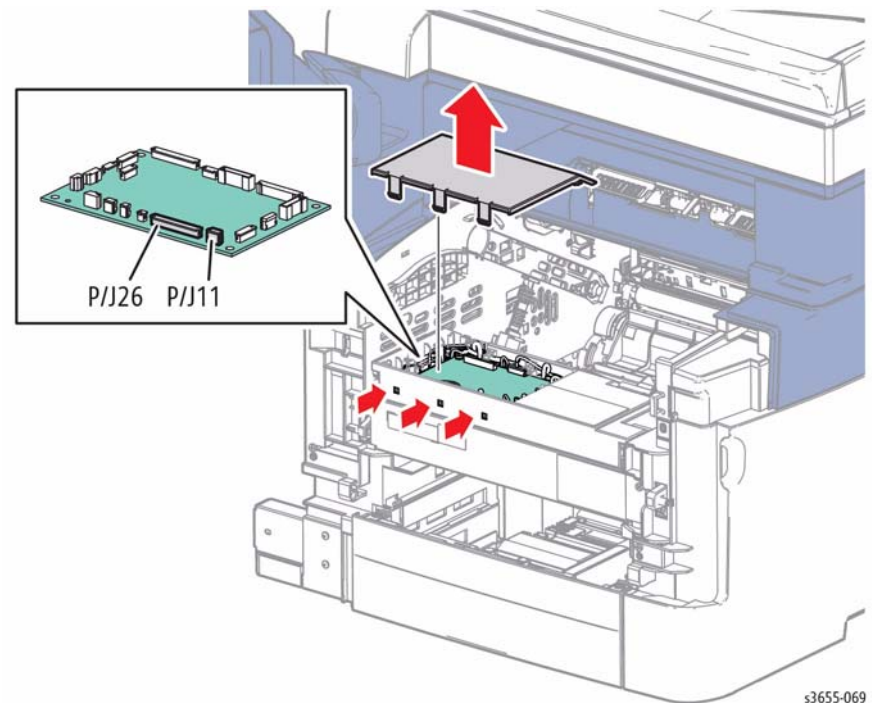

s3655-069

Figure 1 Disconnect the MCU Board

5. Refer to Figure 2 to locate and remove 2 screws (silver, M3, 6mm) that secure the MCU Housing to the chassis.

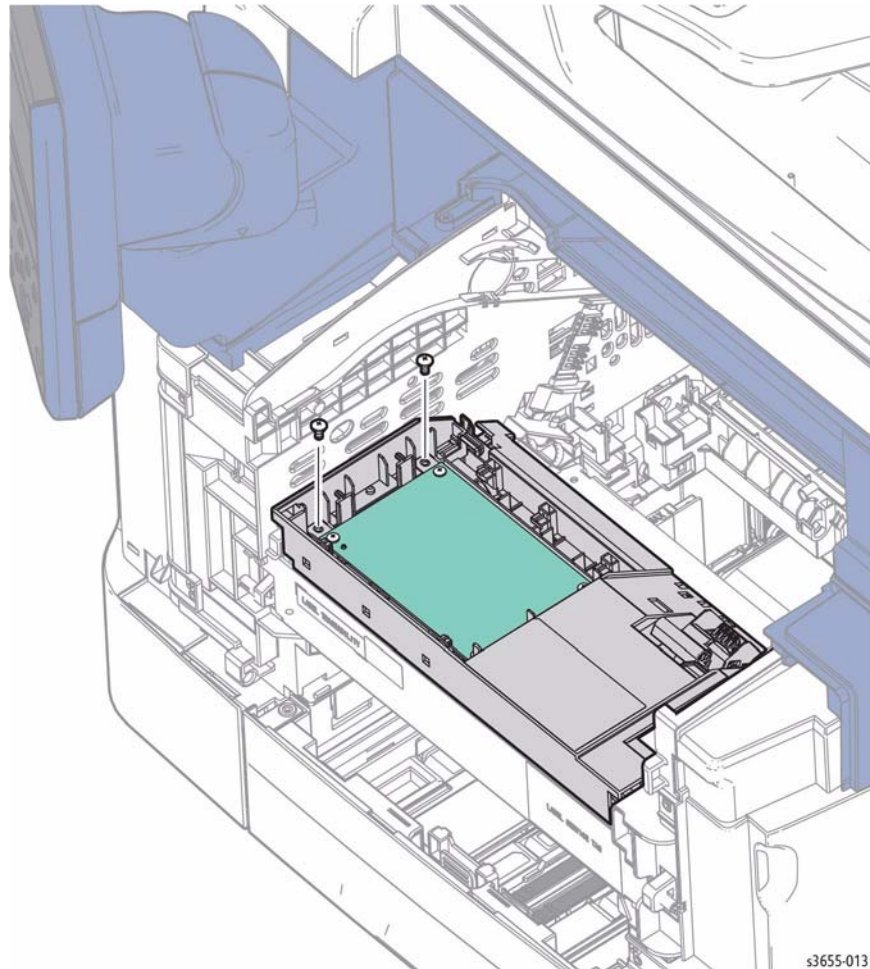

Figure 2 Release the MCU Housing

6. Disconnect the Toner CRUM and release the Toner CRUM harness from the MCU housing cover.
7. Release the harnesses from the MCU housing harness guides to provide enough slack to move the MCU housing to the front of the printer.
8. Refer to Figure 3 to locate and release the right side hook and rotate the MCU housing toward the front, then up off of the pins.

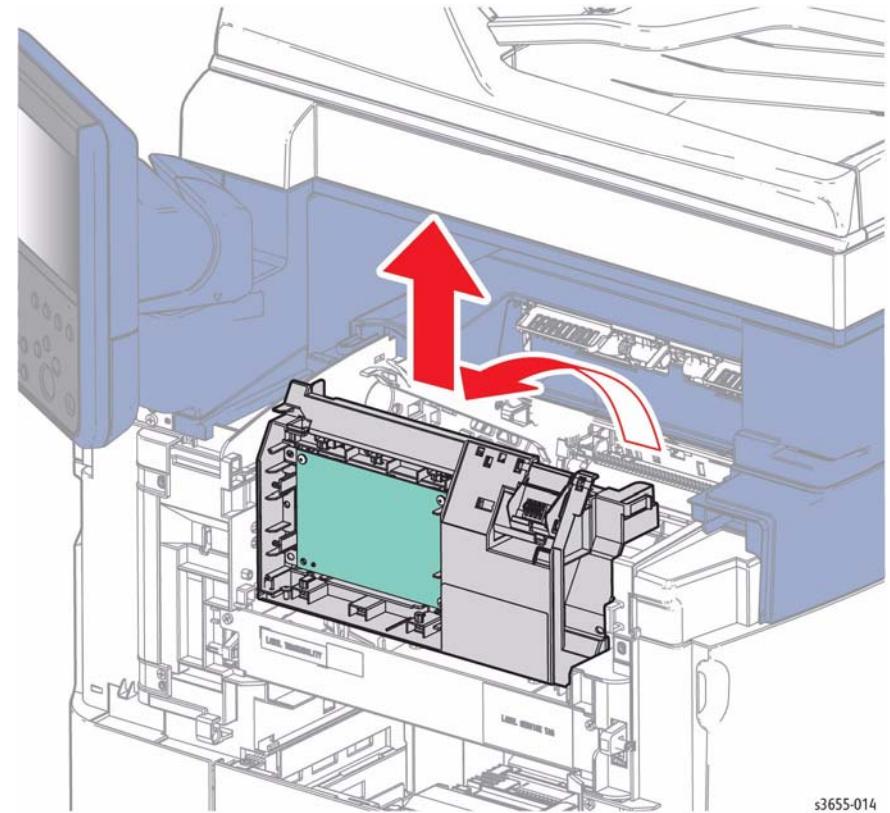

Figure 3 Rotate the MCU Housing

9. Rest the MCU housing on the front of the printer.
10. Refer to Figure 4 to locate and remove 1 screw (silver, tapping, 8mm) that secures the motor.
11. Disconnect the Toner Dispense Motor, then rotate the motor counterclockwise to remove.

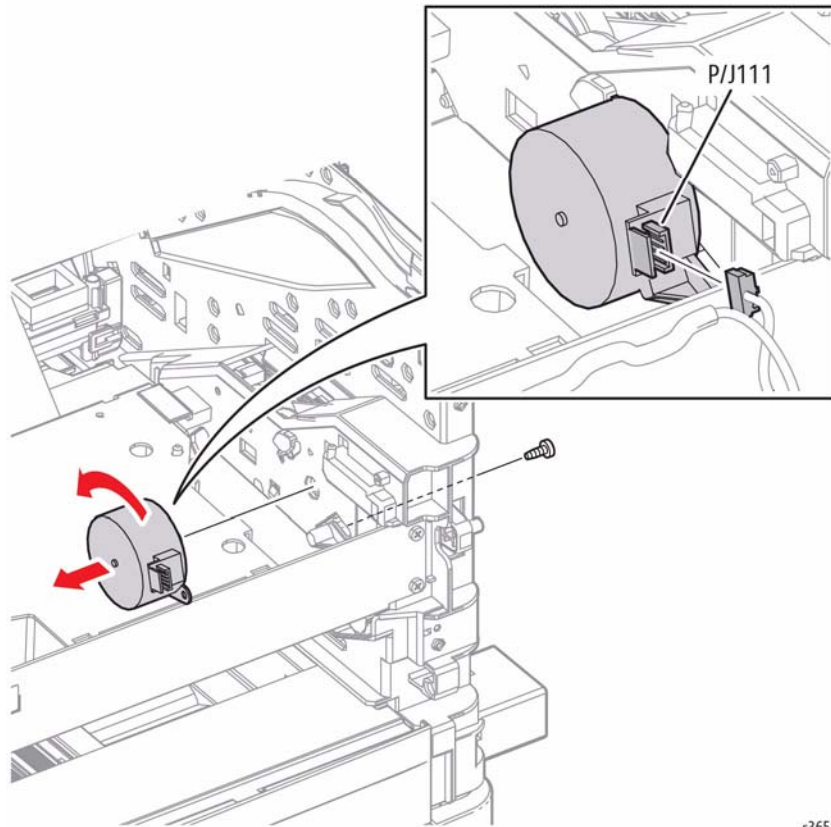

Figure 4 Remove the Toner Dispense Motor

s3655-029

Replacement

Make sure the MCU Housing is seated correctly on the pins so it can be rotated back into the proper position.

REP 5.1.10 Xerographic Connector

Parts List on PL 5.1 Item 10

Removal

WARNING

Switch off the electricity to the machine. Disconnect the power cord from the customer supply while performing tasks that do not need electricity. Electricity can cause death or injury. Moving parts can cause injury.

CAUTION

Cover the Drum Cartridge after removal to prevent light exposure.

1. Remove the Bypass Tray, REP 13.2.9.
2. Remove the Drum Cartridge, REP 8.1.1.
3. Release 3 clips to remove the MCU Board cover.
4. Refer to Figure 1 to locate and disconnect all MCU Board connections except PJ11,18 and 26.

NOTE: Do not remove the MCU Board.

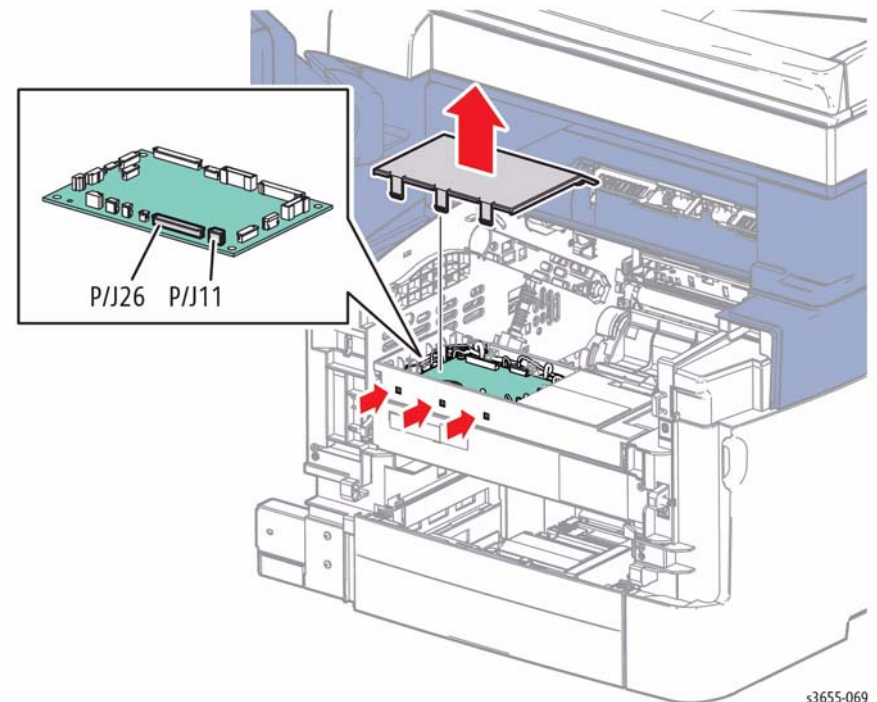

Figure 1 Disconnect the MCU Board

s3655-069

5. Release the Xerographic Connector harnesses from the MCU housing harness guides to provide enough slack to lift the Xerographic Connector from the chassis.

- Refer to Figure 2 to locate and release the clip at the top of the connector and release the Connector harness from the chassis by gently pulling enough slack to disconnect the connector and remove.

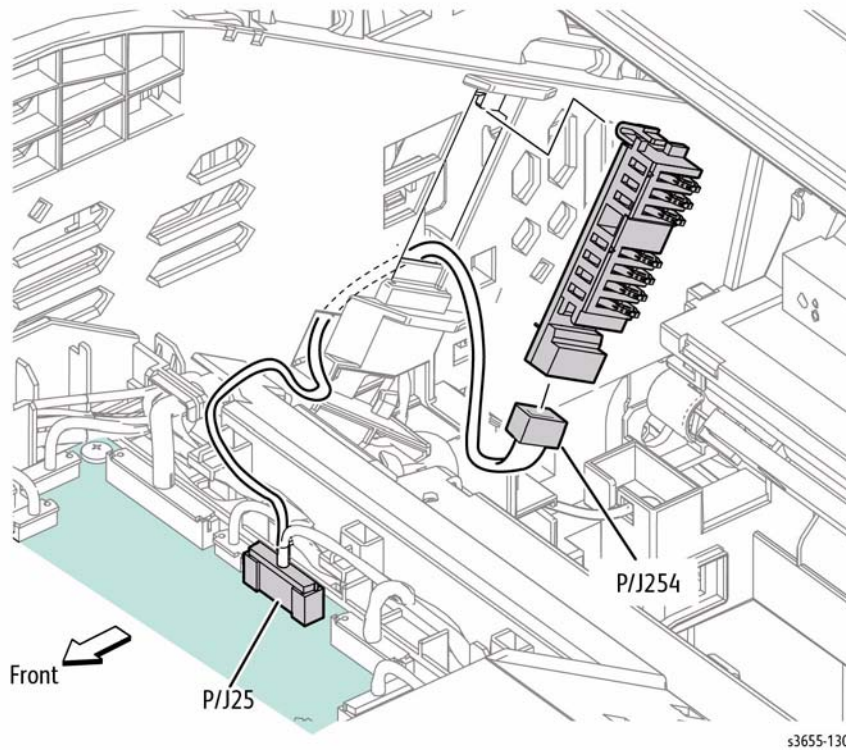

Figure 2 Remove the Xerographic Connector

Replacement

Check harness routing to ensure the Drum Cartridge does not contact any harnesses.

REP 5.1.99 Toner CRUM Assembly

Parts List on PL 5.1 Item 99

Removal

WARNING

Switch off the electricity to the machine. Disconnect the power cord from the customer supply while performing tasks that do not need electricity. Electricity can cause death or injury. Moving parts can cause injury.

CAUTION

Cover the Drum Cartridge after removal to prevent light exposure.

- Open the Front Cover.
- Remove the Drum Cartridge, REP 8.1.1.
- Refer to Figure 1 to locate and release the clip to open the Toner CRUM Assembly and disconnect the assembly.

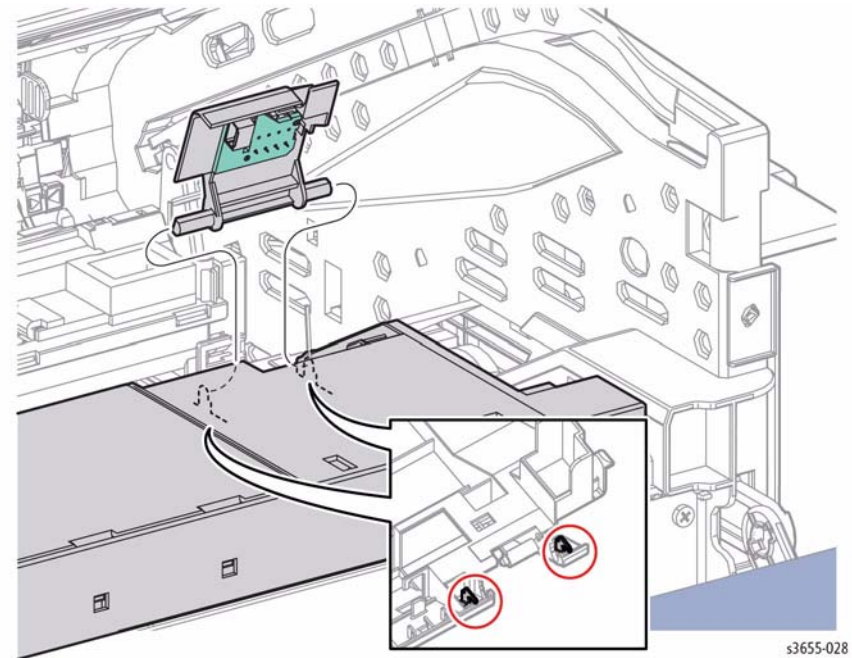

Figure 1 Remove the Toner CRUM Assembly

Replacement

- You may need to release the wire harness in the housing to connect the Toner CRUM.
- When closing the assembly, refer to Figure 2 to properly install the spring.

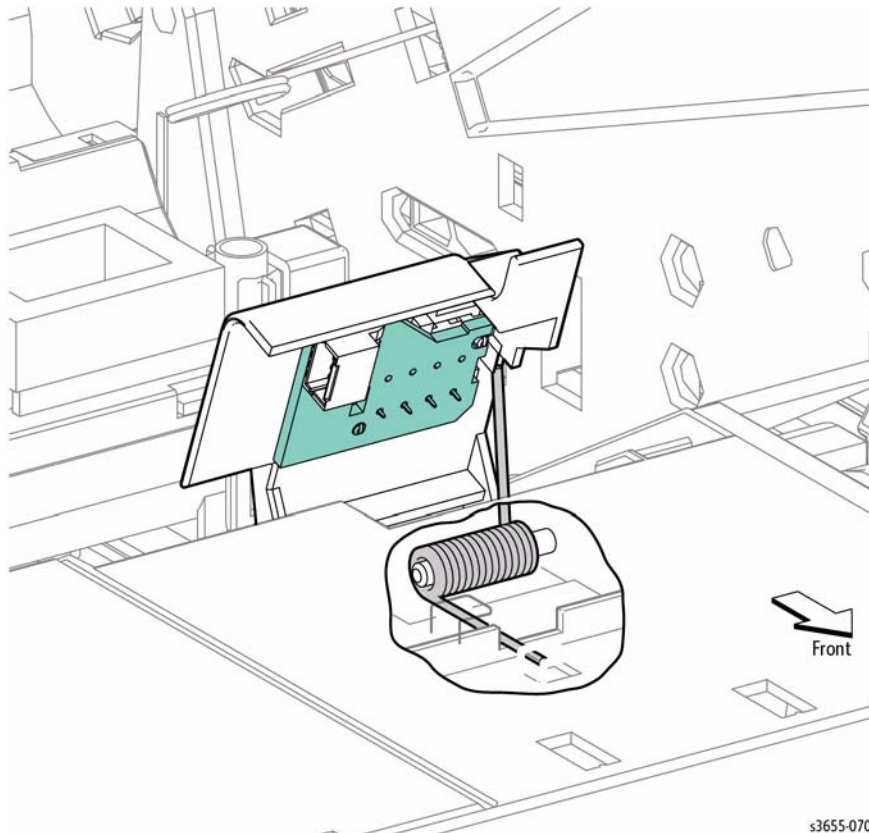

Figure 2 Toner CRUM Spring Position

s3655-070

REP 6.1.1 Transfer Roller

Parts List on PL 6.1 Item 1

Removal

WARNING

Switch off the electricity to the machine. Disconnect the power cord from the customer supply while performing tasks that do not need electricity. Electricity can cause death or injury. Moving parts can cause injury.

WARNING

Do not touch the Fuser while it is hot.

1. Open the Rear Cover.
2. Refer to Figure 1 to locate and release 2 clips and rotate the Transfer Roller up to remove.

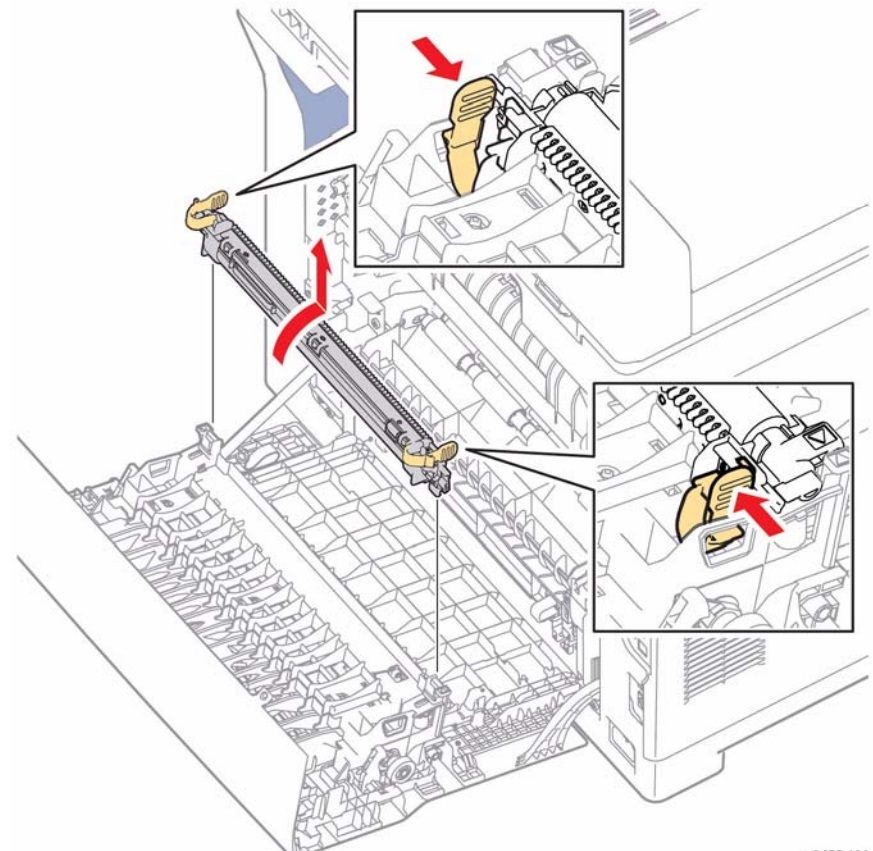

Figure 1 Remove the Transfer Roller

Replacement

After Transfer Roller replacement, reset the counter.

REP 7.1.1 Fuser

Parts List on PL 7.1 Item 1

Removal

WARNING

Switch off the electricity to the machine. Disconnect the power cord from the customer supply while performing tasks that do not need electricity. Electricity can cause death or injury. Moving parts can cause injury.

WARNING

Do not touch the Fuser while it is hot.

1. Open the Rear Cover.
2. Refer to Figure 1 to locate and rotate the Fuser locking levers to unlock the Fuser.
3. Pull to disconnect and remove the Fuser.

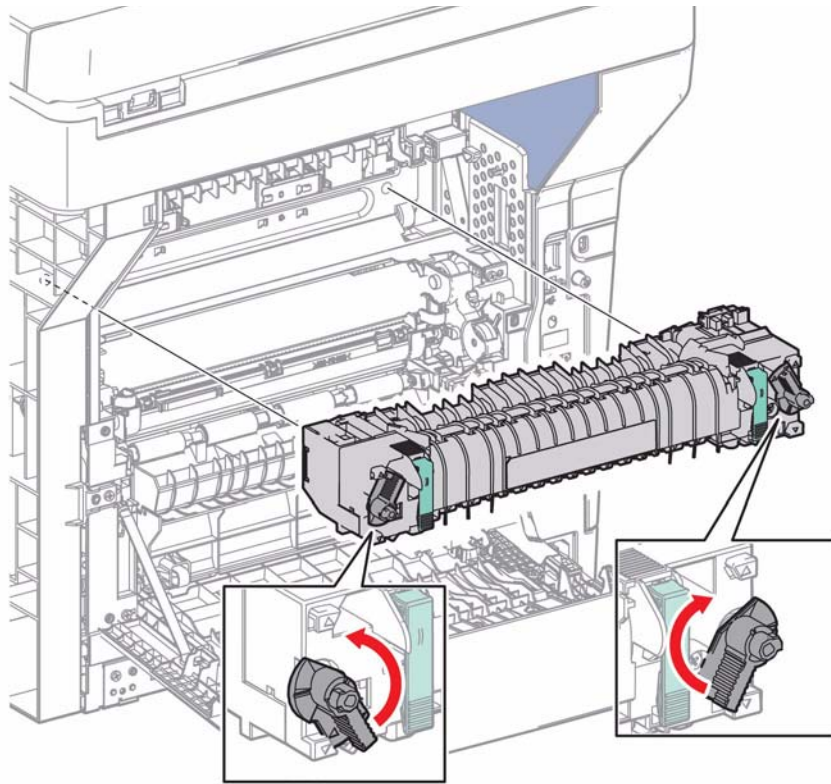

s3655-121

Figure 1 Remove the Fuser

Replacement

After Fuser replacement, reset the counter.

REP 8.1.1 Drum Cartridge

Parts List on PL 8.1 Item 1

Removal

WARNING

Switch off the electricity to the machine. Disconnect the power cord from the customer supply while performing tasks that do not need electricity. Electricity can cause death or injury. Moving parts can cause injury.

CAUTION

Cover the Drum Cartridge after removal to prevent light exposure.

CAUTION

Use care when handling Toner Cartridges. Protect the work area from damage due to Toner spills and use an approved toner vacuum when cleaning toner from the printer or work area.

1. Open the Front Cover.
2. Refer to Figure 1 and pull the Drum Cartridge from the printer using the handle provided.

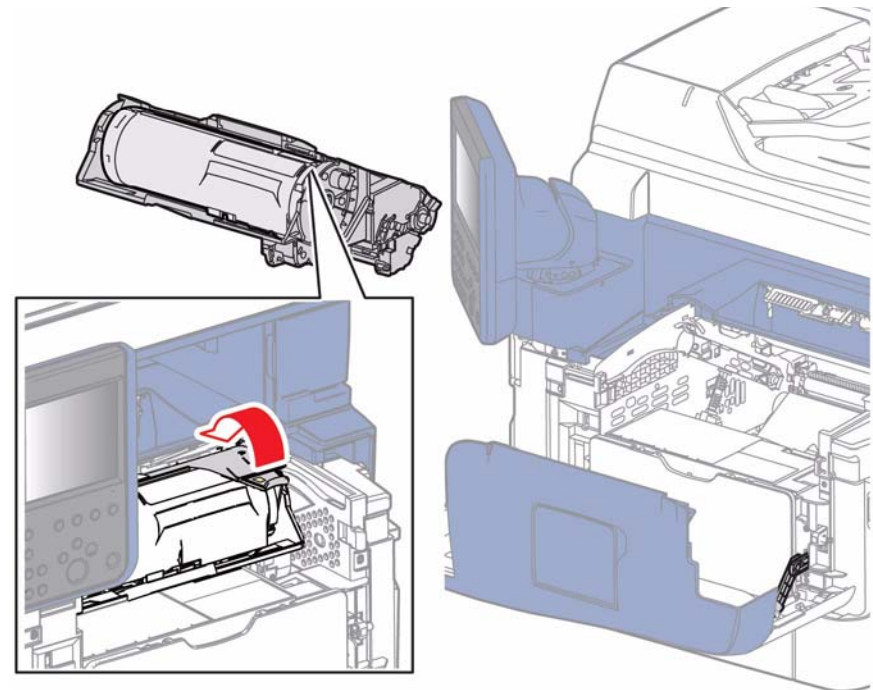

s3655-142

Figure 1 Remove the Drum Cartridge

Replacement

Transfer the Toner Cartridge to the replacement Drum Cartridge.

REP 8.1.2 Toner Cartridge

Parts List on PL 8.1 Item 2

Removal

WARNING

Switch off the electricity to the machine. Disconnect the power cord from the customer supply while performing tasks that do not need electricity. Electricity can cause death or injury. Moving parts can cause injury.

CAUTION

Use care when handling Toner Cartridges. Protect the work area from toner spills and use an approved toner vacuum when cleaning toner from the printer or work area.

1. Open the Front Cover.
2. Refer to Figure 1 to locate and release the Toner Cartridge lock, then lift the Toner Cartridge from the Drum Cartridge.

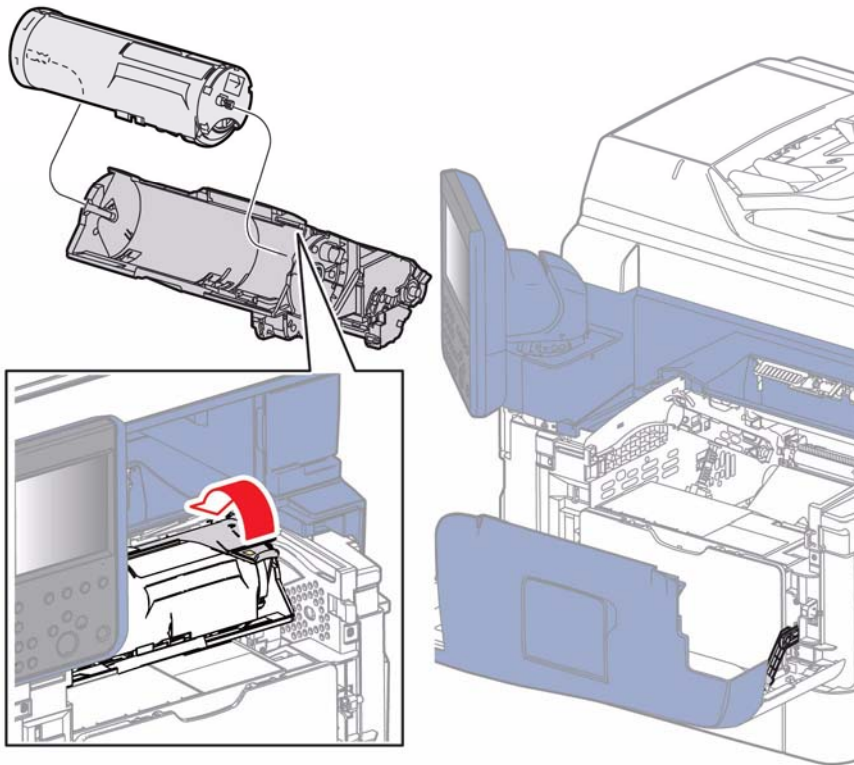

Figure 1 Remove the Toner Cartridge

Replacement

Lock the Toner Cartridge into position.

REP 9.2.98 Feed Roll Kit

Parts List on PL 9.2 Item 98

Removal

WARNING

Switch off the electricity to the machine. Disconnect the power cord from the customer supply while performing tasks that do not need electricity. Electricity can cause death or injury. Moving parts can cause injury.

The Feed Roll Kit provides 3 rollers to replace the Feed and Nudger rollers for the feeder, and a Retard Roller for the Tray.

1. Remove Tray 1.
2. Refer to Figure 1 to locate and release the clips that secure the Feed and Nudger Rollers to the shafts.

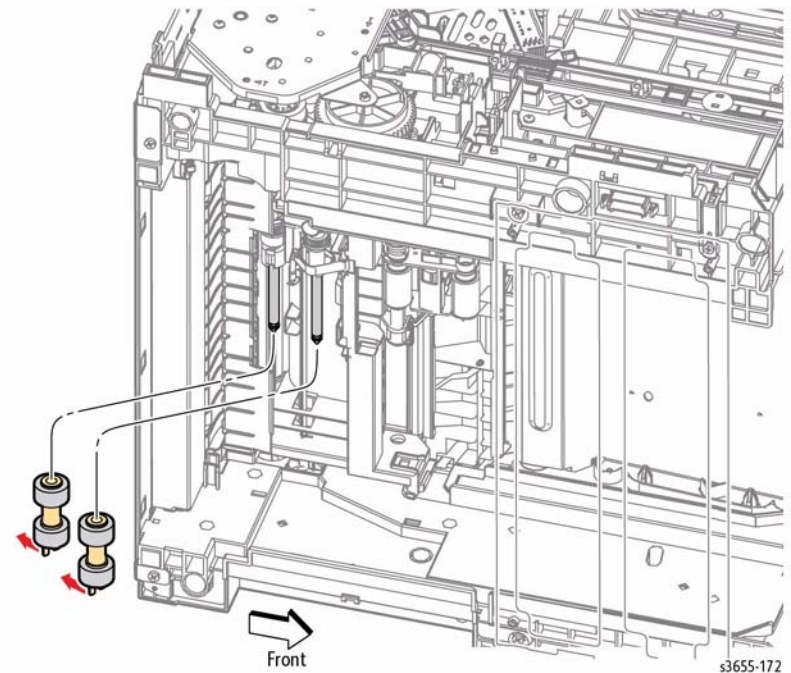

Figure 1 Remove the Feed and Nudger Rollers

3. Remove the Retard Roller Assembly, REP 9.2.99.
4. Replace the Retard Roller, then reassemble the Retard Roller Assembly and install.

Replacement

Make sure the tabs on the bottom of the rollers engage the notches on the Feed Assembly and the rollers are firmly locked into place.

REP 9.2.99 Retard Roll Kit

Parts List on PL 9.2 Item 99

Removal

WARNING

Switch off the electricity to the machine. Disconnect the power cord from the customer supply while performing tasks that do not need electricity. Electricity can cause death or injury. Moving parts can cause injury.

1. Remove the Tray.
2. Refer to Figure 1 to locate and release the hook that secures the Retard Roller Assembly in the Tray.

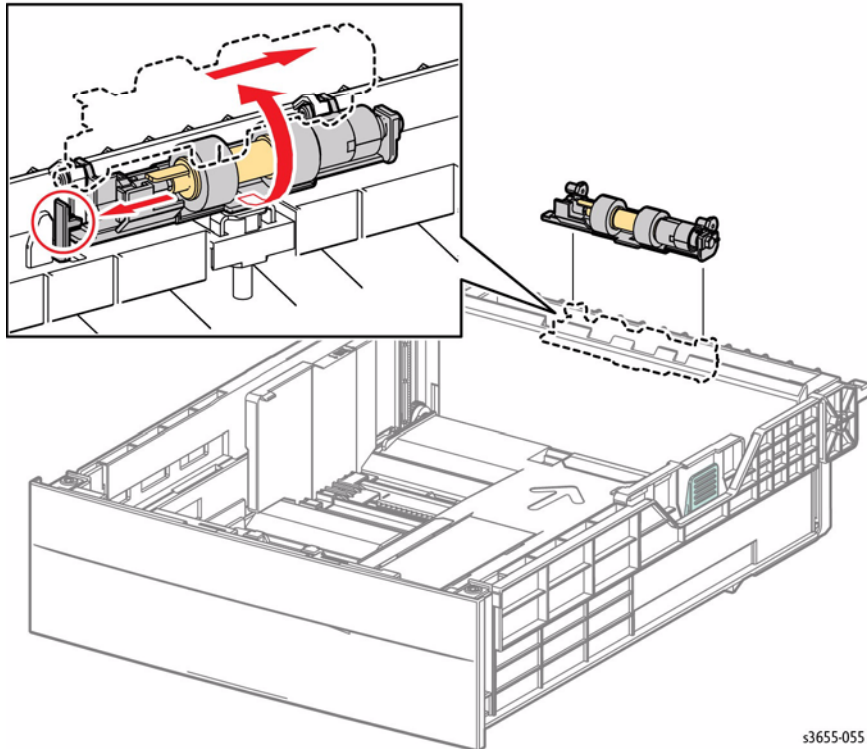

Figure 1 Remove the Retard Roller Assembly

3. Rotate the holder upward, then move the assembly right to remove.
4. Release the hook that secures the Retard Roller shaft to the assembly.
5. Release the hook that secures the Retard roller to the shaft to remove.

Replacement

install the replacement roller and reassemble the Retard Roller Assembly, then install in Tray 1,

REP 11.1.2 Optional Feeder Left Side Cover

Parts List on PL 11.1 Item 2

Removal

WARNING

Switch off the electricity to the machine. Disconnect the power cord from the customer supply while performing tasks that do not need electricity. Electricity can cause death or injury. Moving parts can cause injury.

WARNING

Use safe handling procedures when removing the module. Refer to GP 16. The module is heavy.

1. Remove the Tray from the Optional Feeder.
2. Remove the Optional Feeder, REP 11.1.99.
3. Refer to Figure 1 to locate and remove 1 screw (silver, tapping, 8mm) and release 2 tabs to remove the left side cover.

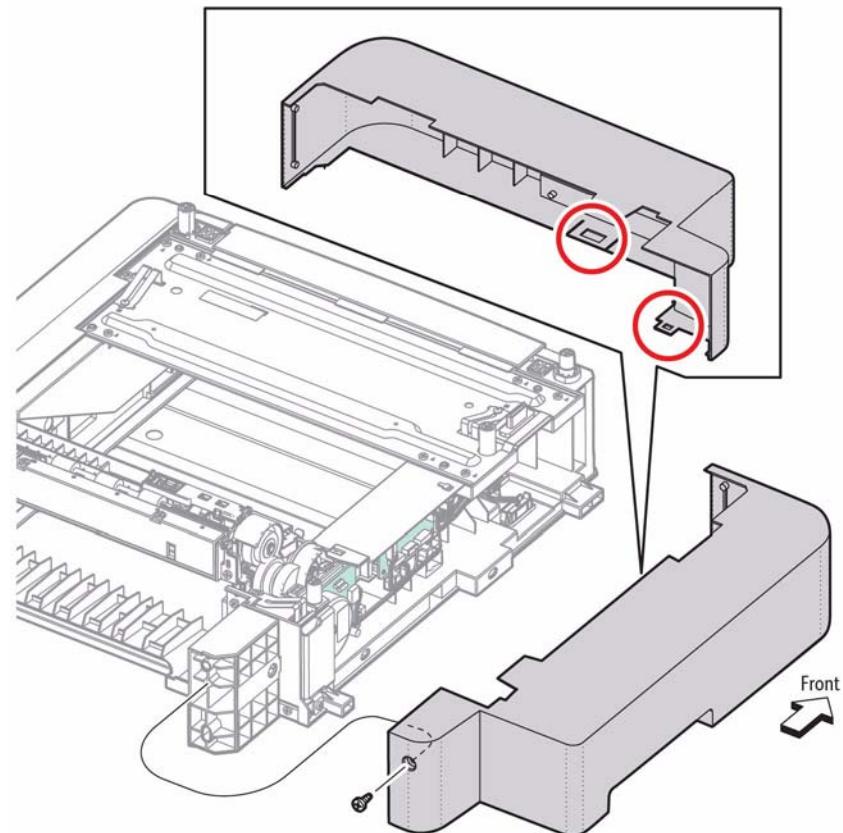

Figure 1 Remove the Left Side Cover

REP 11.1.5 Optional Feeder Board

Parts List on PL 11.1 Item 5

Removal

WARNING

Switch off the electricity to the machine. Disconnect the power cord from the customer supply while performing tasks that do not need electricity. Electricity can cause death or injury. Moving parts can cause injury.

WARNING

Use safe handling procedures when removing the module. Refer to GP 16. The module is heavy.

1. Remove the Tray from the Optional Feeder.
2. Remove the Optional Feeder, REP 11.1.99.
3. Remove the Optional Feeder left side cover, REP 11.1.2.
4. Refer to Figure 1 to locate and disconnect all Optional Feeder Board connections.

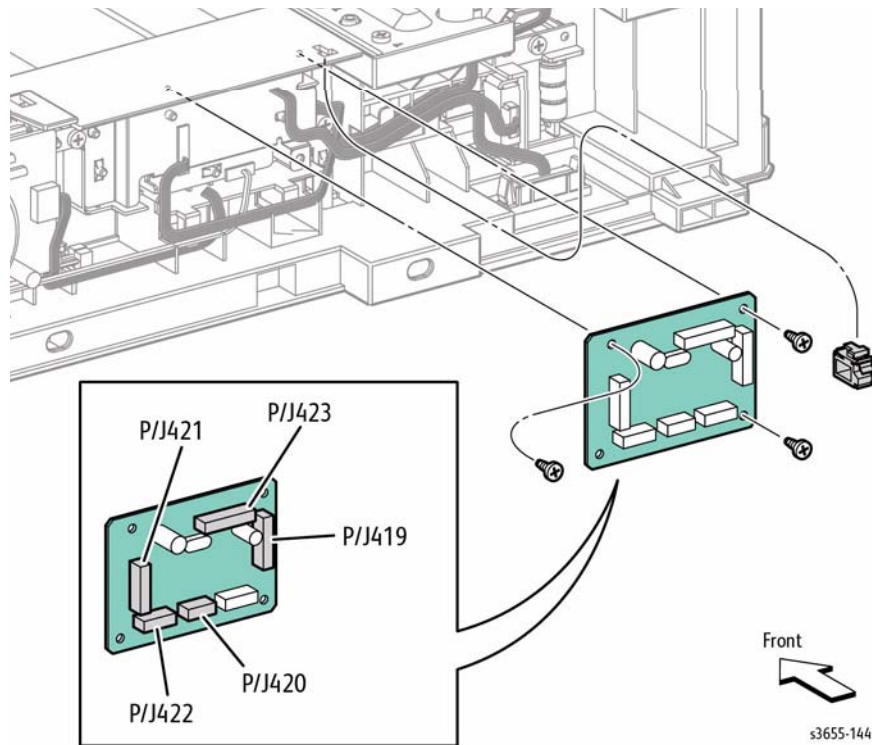

Figure 1 Remove the Feeder Board

5. Remove 3 screws (silver, tapping, 8mm) that secure the board.
6. Release the harnesses from the clamp and remove the clamp and board.

REP 11.1.7 Optional Feeder Drive

Parts List on PL 11.1 Item 7

Removal

WARNING

Switch off the electricity to the machine. Disconnect the power cord from the customer supply while performing tasks that do not need electricity. Electricity can cause death or injury. Moving parts can cause injury.

WARNING

Use safe handling procedures when removing the module. Refer to GP 16. The module is heavy.

1. Remove the Tray from the Optional Feeder.
2. Remove the Optional Feeder, REP 11.1.99.
3. Remove the Optional Feeder left side cover, REP 11.1.2.
4. Refer to Figure 1 to locate and remove 2 screws (silver, tapping, 8mm, and silver, metal, 8mm) and lift the ground straps to remove the motor cover.

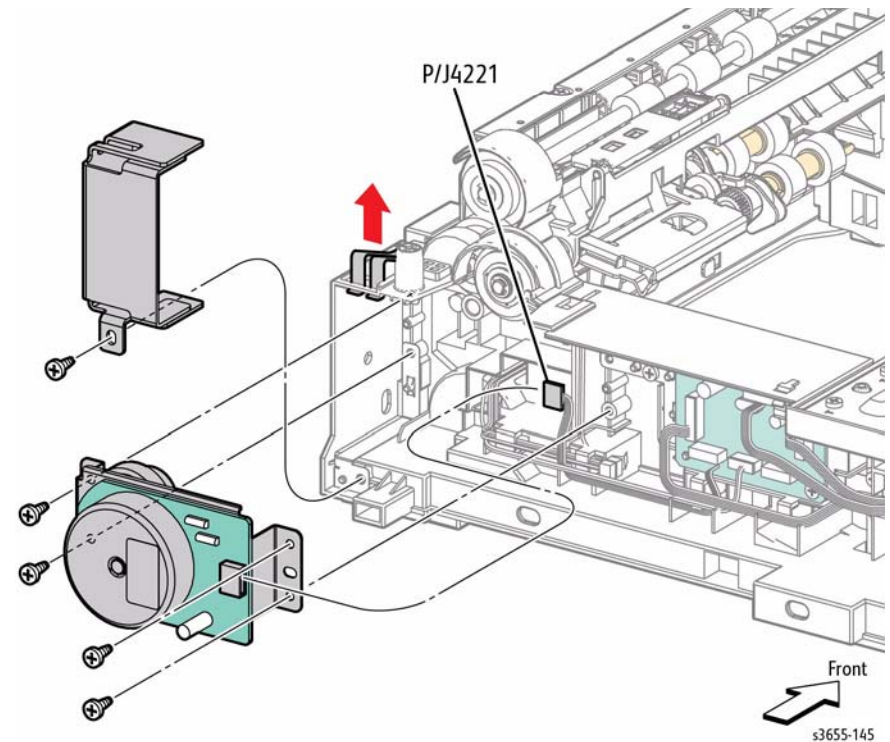

Figure 1 Remove the Feed Motor

5. Disconnect the motor.
6. Remove 4 screws (silver, tapping, 8mm) that secure the motor to the chassis.

REP 11.1.8 Optional Feeder Feed Clutch

Parts List on PL 11.1 Item 8

Removal

WARNING

Switch off the electricity to the machine. Disconnect the power cord from the customer supply while performing tasks that do not need electricity. Electricity can cause death or injury. Moving parts can cause injury.

WARNING

Use safe handling procedures when removing the module. Refer to GP 16. The module is heavy.

1. Remove the Tray from the Optional Feeder.
2. Remove the Optional Feeder, REP 11.1.99.
3. Remove the Optional Feeder left side cover, REP 11.1.2.
4. Remove the Optional Feeder Drive Assembly, REP 11.1.7.
5. Refer to Figure 1 to locate and disconnect the Feed Clutch.

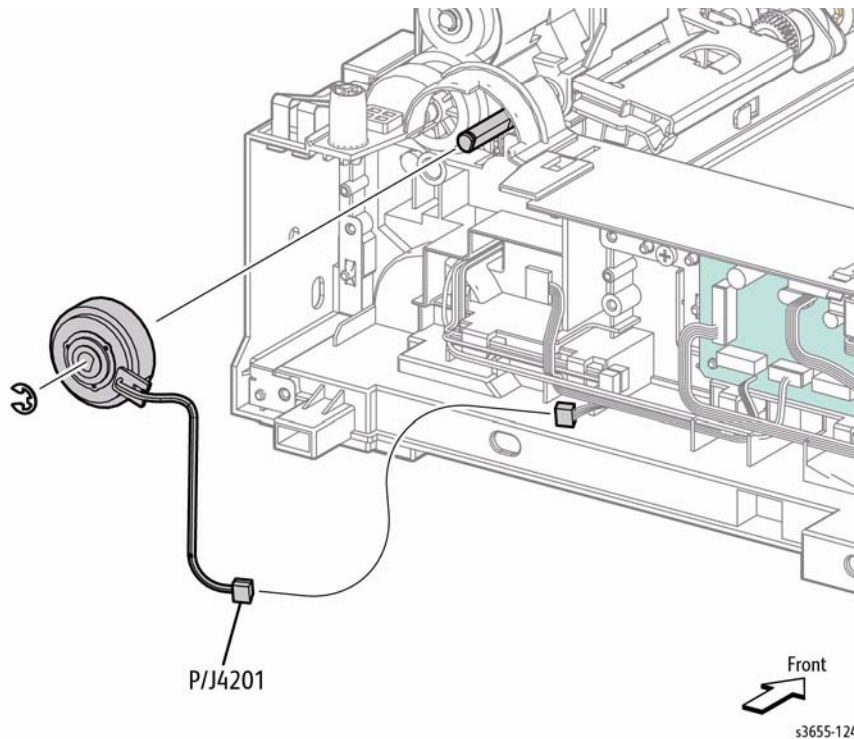

Figure 1 Remove the Feed Clutch

6. Release the clutch harness from the harness guide.
7. Remove the E-ring that secures the Feed Clutch to the shaft.

REP 11.1.20 Optional Feeder Feed Assembly

Parts List on PL 11.1 Item 20

Removal

WARNING

Switch off the electricity to the machine. Disconnect the power cord from the customer supply while performing tasks that do not need electricity. Electricity can cause death or injury. Moving parts can cause injury.

WARNING

Use safe handling procedures when removing the module. Refer to GP 16. The module is heavy.

1. Remove the Tray from the Optional Feeder.
2. Remove the Optional Feeder, REP 11.1.99.
3. Remove the Optional Feeder left side cover, REP 11.1.2.
4. Remove the Optional Feeder Drive Assembly, REP 11.1.7.
5. Remove the Optional Feeder Feed Clutch, REP 11.1.8.
6. Refer to Figure 1 to locate and disconnect the Feed Assembly.

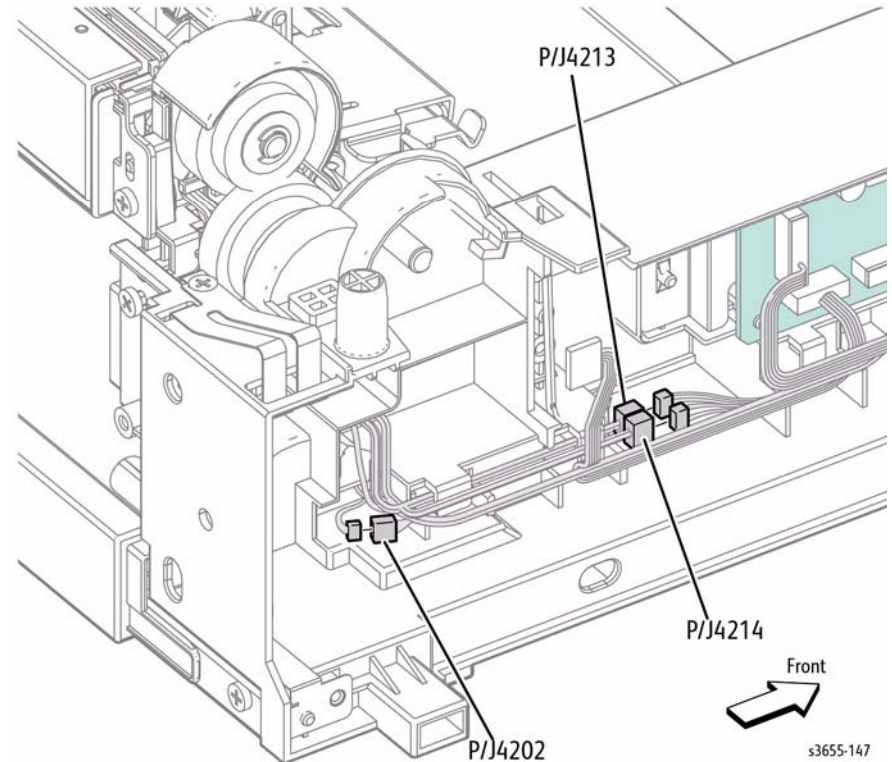

Figure 1 Disconnect the Feed Assembly

7. Release the feeder harness from the guides.
8. Refer to Figure 2 to locate and remove 2 screws (silver, tapping, 8mm) behind rear cover and feed shaft bearing.

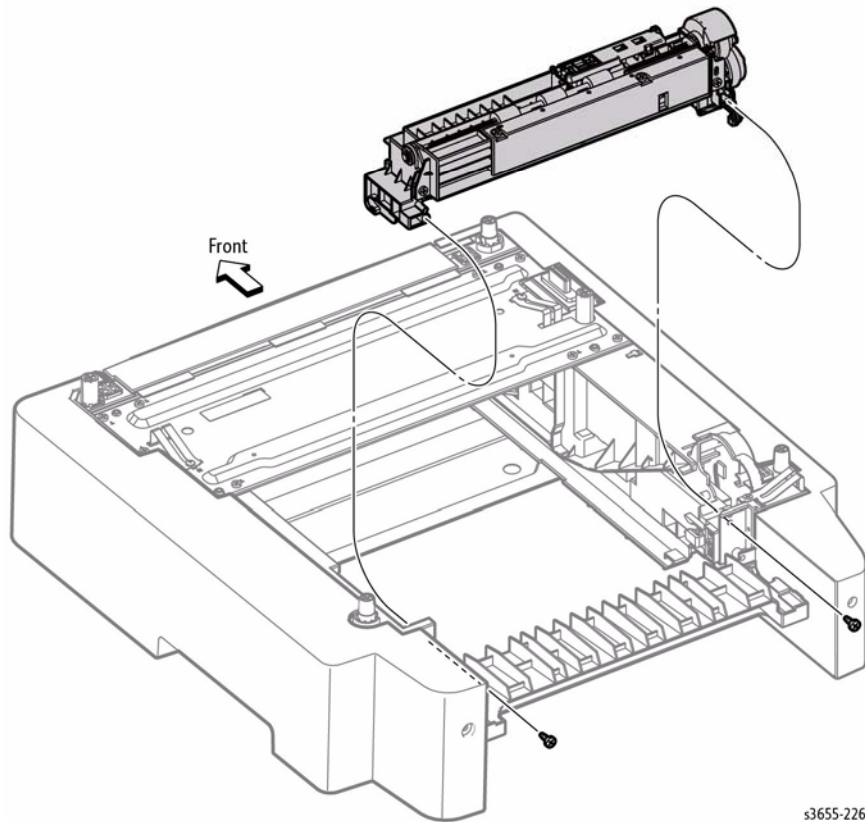

Figure 2 Remove the Feed Assembly

9. Lift the Feed Assembly on the right, then move right to release the shaft from the chassis.

Replacement

1. Install the bearing to the shaft.
2. Seat the assembly completely before installing the screws.

REP 11.1.27 Optional Feeder Tray Stopper

Parts List on PL 11.1 Item 27

Removal

WARNING

Switch off the electricity to the machine. Disconnect the power cord from the customer supply while performing tasks that do not need electricity. Electricity can cause death or injury. Moving parts can cause injury.

1. Remove the Tray.
2. Open the Option Feeder rear cover.
3. Refer to Figure 1 to locate and remove 1 screw (silver, tapping, 8mm) that secures the Tray Stopper to the chassis.

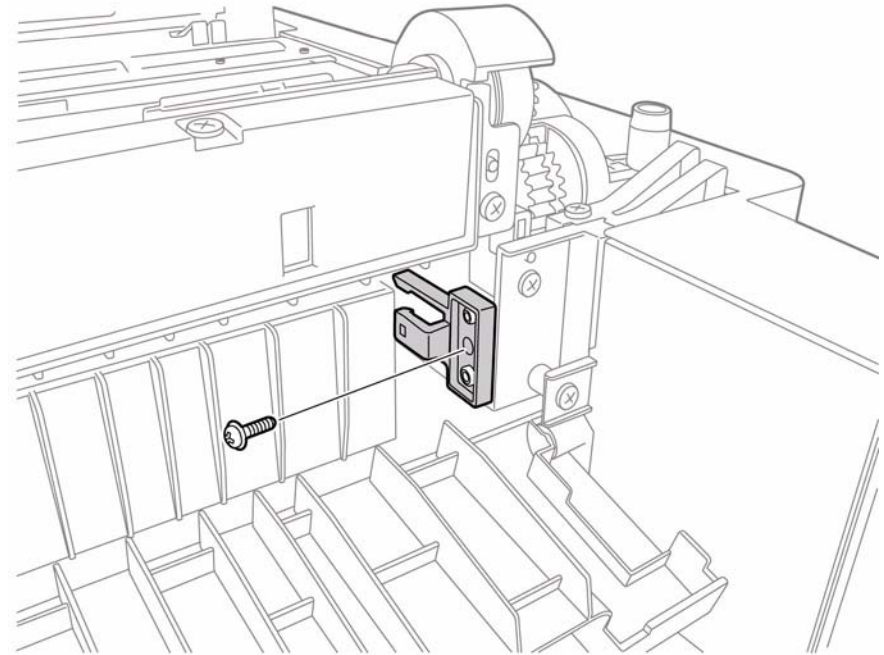

Figure 1 Remove the Tray Stopper

REP 11.1.99 Optional 550-Sheet Feeder

Parts List on PL 11.1 Item 99

Removal

WARNING

Switch off the electricity to the machine. Disconnect the power cord from the customer supply while performing tasks that do not need electricity. Electricity can cause death or injury. Moving parts can cause injury.

WARNING

Use safe handling procedures when removing the module. Refer to GP 16. The module is heavy.

1. Remove the Bypass Tray.
2. Remove Tray 1 and the Tray from the Optional Feeder.
3. Refer to Figure 1 to locate and remove 2 screw locks that secure the feeder to the printer.

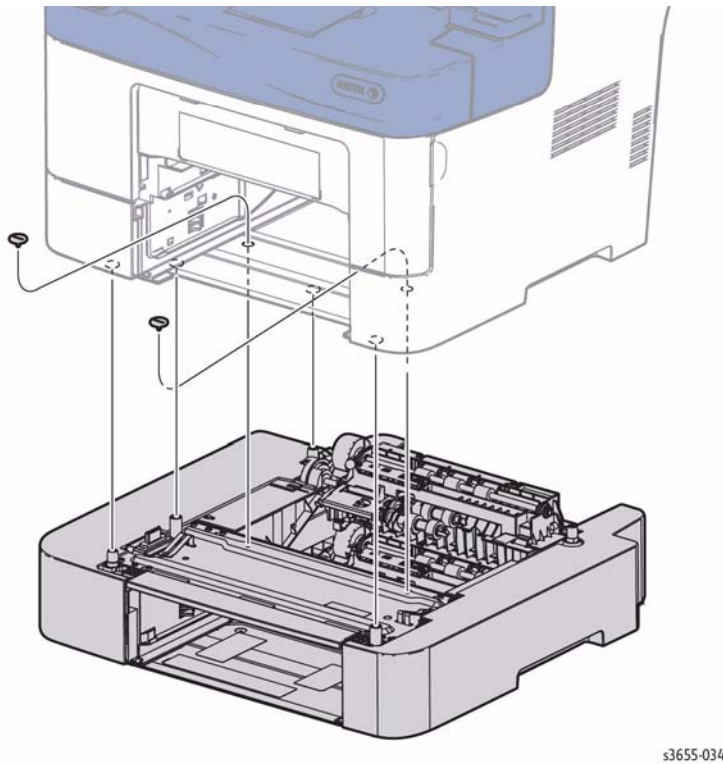

Figure 1 Remove the Optional Feeder

s3655-034

4. Lift the printer to separate it from the feeder.

Replacement

Carefully align the option feeder connector before setting the printer on the bosses.

REP 11.2.2 Optional Feeder No Paper Sensor

Parts List on PL 11.2 Item 2

Removal

WARNING

Switch off the electricity to the machine. Disconnect the power cord from the customer supply while performing tasks that do not need electricity. Electricity can cause death or injury. Moving parts can cause injury.

WARNING

Use safe handling procedures when removing the module. Refer to GP 16. The module is heavy.

1. Remove the Tray from the Optional Feeder.
2. Remove the Optional Feeder, REP 11.1.99.
3. Release 1 hook to open the sensor cover.
4. Refer to Figure 1 to locate and release 3 clips that secure the sensor holder to the Feeder Assembly, then disconnect and remove the No Paper Sensor.

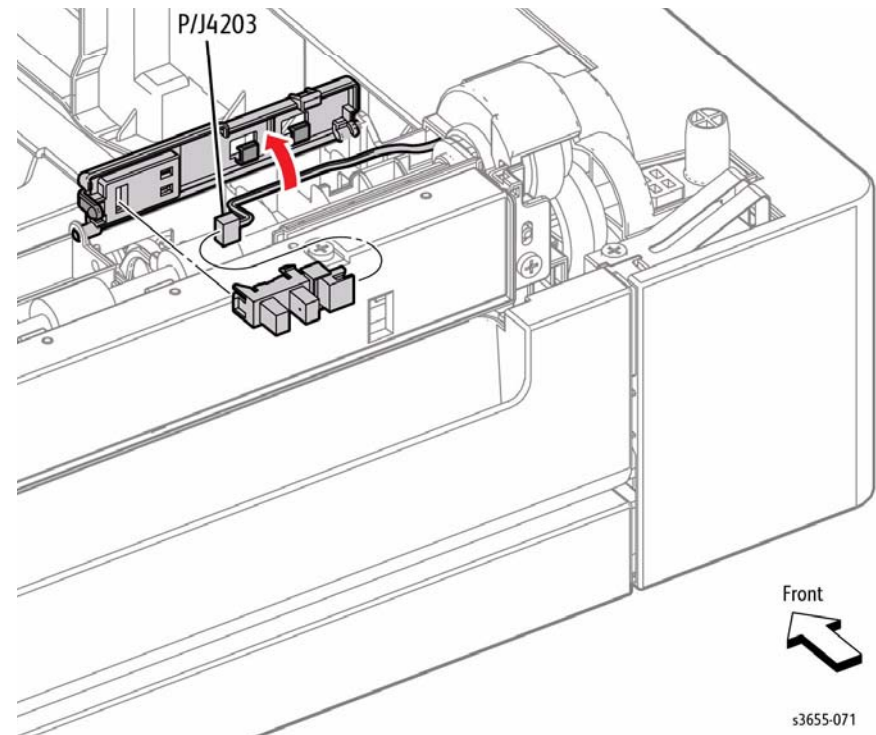

Figure 1 Remove the No Paper Sensor

s3655-071

Replacement

Secure the left side of the holder to the feeder first.

REP 11.2.11 Optional Feeder No Paper Sensor Acuator

Parts List on PL 11.2 Item 11

Removal

WARNING

Switch off the electricity to the machine. Disconnect the power cord from the customer supply while performing tasks that do not need electricity. Electricity can cause death or injury. Moving parts can cause injury.

WARNING

Use safe handling procedures when removing the module. Refer to GP 16. The module is heavy.

1. Remove the Tray from the Optional Feeder.
2. Remove the Optional Feeder, REP 11.1.99.
3. Refer to Figure 1 to locate and remove the E-clip that secures the actuator to the Feed Assembly.

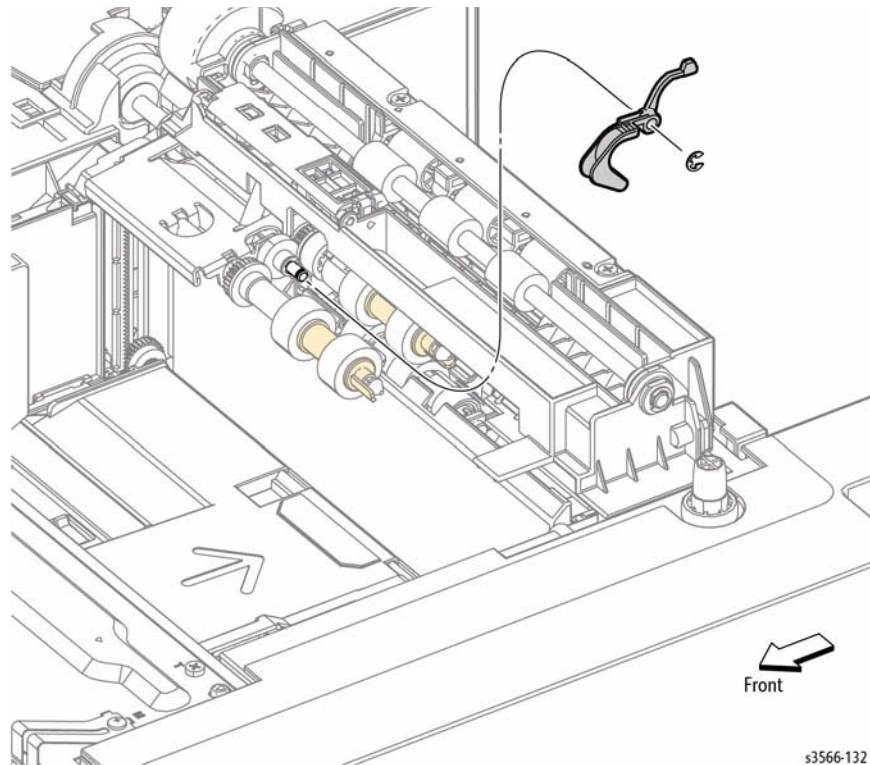

Figure 1 Remove the No Paper Sensor Actuator

Replacement

Check operation of the actuator.

REP 11.2.20 Optional Feeder Registration Clutch

Parts List on PL 11.2 Item 20

Removal

WARNING

Switch off the electricity to the machine. Disconnect the power cord from the customer supply while performing tasks that do not need electricity. Electricity can cause death or injury. Moving parts can cause injury.

WARNING

Use safe handling procedures when removing the module. Refer to GP 16. The module is heavy.

1. Remove the Tray from the Option Feeder.
2. Remove the Optional Feeder, REP 11.1.99.
3. Remove the Optional Feeder left side cover, REP 11.1.2.
4. Remove the Option Feeder Drive Assembly, REP 11.1.7.
5. Remove the Option Feeder Feed Clutch, REP 11.1.8.
6. Remove the Option Feeder Feed Assembly, REP 11.1.20.
7. Refer to Figure 1 to locate and remove the idler gear, 1 screw (silver, tapping, 8mm), E-ring, and disconnect the Registration Clutch to remove.

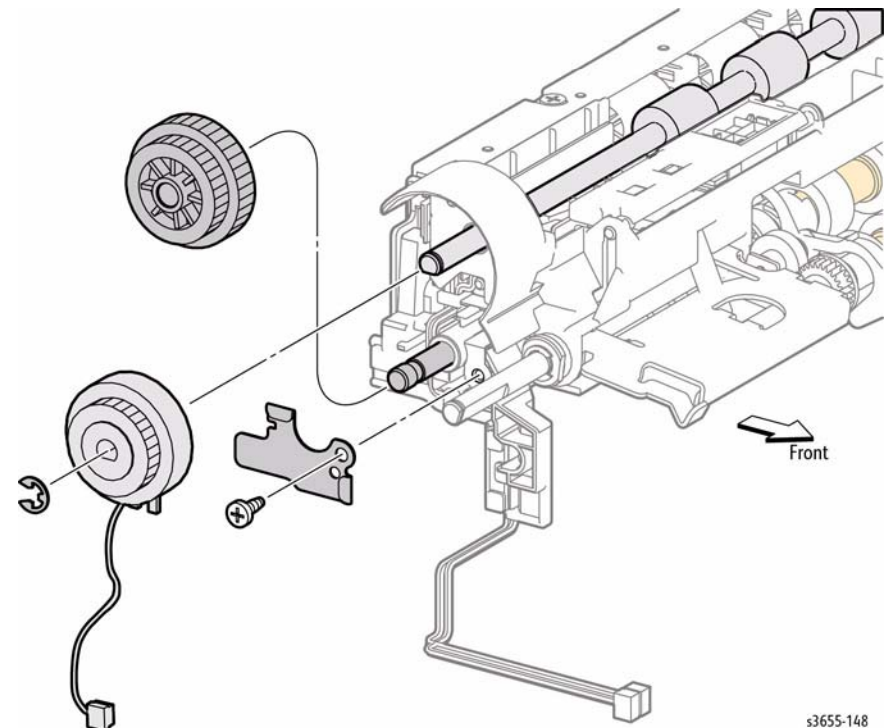

Figure 1 Remove the Registration Clutch

REP 11.2.21 Optional Feeder Take Away Roller

Parts List on PL 11.2 Item 21

Removal

WARNING

Switch off the electricity to the machine. Disconnect the power cord from the customer supply while performing tasks that do not need electricity. Electricity can cause death or injury. Moving parts can cause injury.

WARNING

Use safe handling procedures when removing the module. Refer to GP 16. The module is heavy.

1. Remove the Tray from the Option Feeder.
2. Remove the Optional Feeder, REP 11.1.99.
3. Remove the Optional Feeder left side cover, REP 11.1.2.
4. Remove the Option Feeder Drive Assembly, REP 11.1.7.
5. Remove the Option Feeder Feed Clutch, REP 11.1.8.
6. Remove the Option Feeder Feed Assembly, REP 11.1.20.
7. Refer to Figure 1 to locate and remove the E-ring, bearing at either end of the shaft, then move the shaft left to release it from the Feed Assembly.

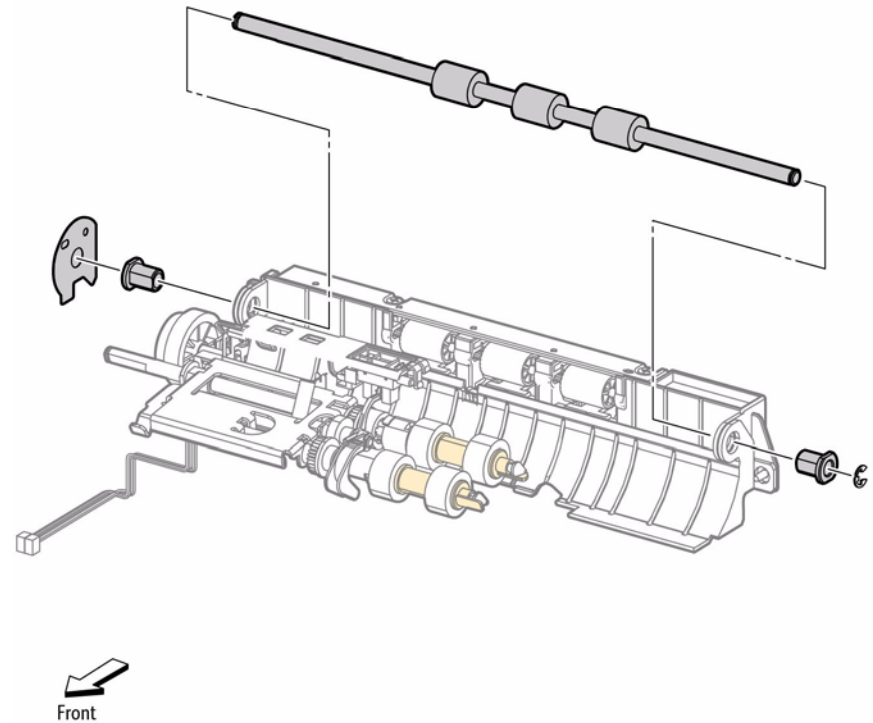

s3566-133

Figure 1 Remove the Take Away Roller

REP 11.4.4 Optional Feeder Path Sensor

Parts List on PL 11.4 Item 4

Removal

WARNING

Switch off the electricity to the machine. Disconnect the power cord from the customer supply while performing tasks that do not need electricity. Electricity can cause death or injury. Moving parts can cause injury.

WARNING

Use safe handling procedures when removing the module. Refer to GP 16. The module is heavy.

1. Remove the Optional Feeder, REP 11.1.99.
2. Refer to Figure 1 to locate and remove 2 screws (silver, tapping, 8mm) that secure a cover on the Feeder Assembly, then disconnect and remove the sensor.

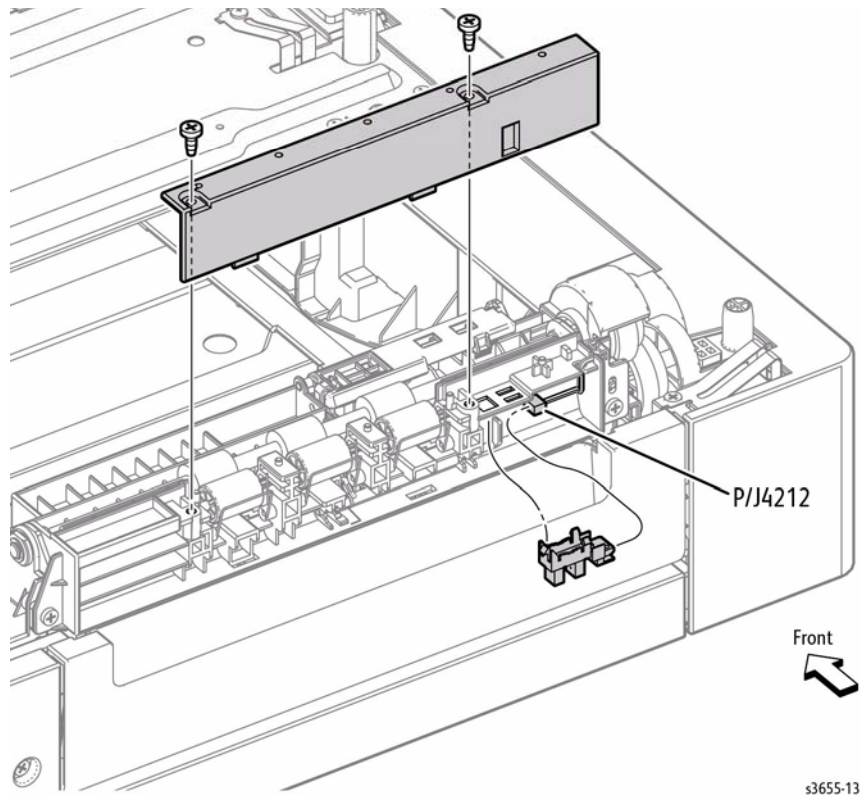

Figure 1 Remove the Path Sensor

Replacement

Standing the feeder on end simplifies replacement. Check actuator operation after installation.

REP 13.1.5 MSI Feed Solenoid

Parts List on PL 13.1 Item 5

Removal

WARNING

Switch off the electricity to the machine. Disconnect the power cord from the customer supply while performing tasks that do not need electricity. Electricity can cause death or injury. Moving parts can cause injury.

WARNING

Do not touch the Fuser while it is hot.

CAUTION

Cover the Drum Cartridge after removal to prevent light exposure.

1. Open the Rear Cover.
2. Remove the Left Rear Cover, REP 19.2.2.
3. Open the Front Cover.
4. Remove the Drum Cartridge.
5. Remove the Left UI Base Cover, REP 1.1.6.
6. Remove the Left Side Cover, REP 19.2.1.
7. Remove the ESS housing cover, REP 18.1.1.
8. Remove the ESS housing, REP 18.1.2.
9. Release 3 hooks to remove the MCU Board Cover.
10. Refer to Figure 1 to locate and disconnect the MSI Feed Solenoid from the MCU Board and release the solenoid harness from the guides on both sides of the chassis.

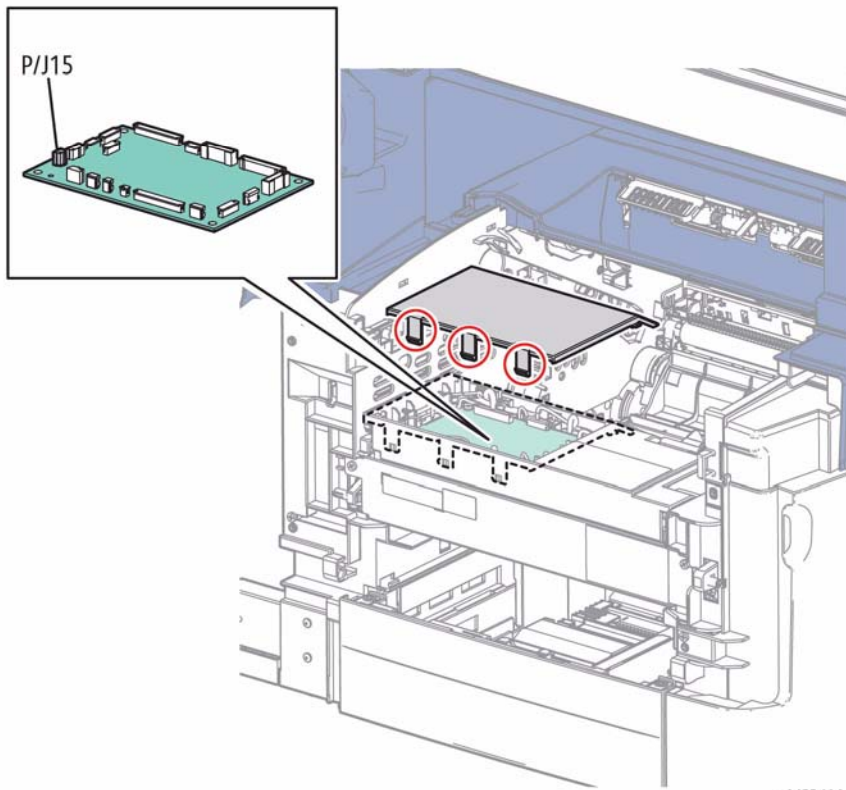

Figure 1 Disconnect the MSI Solenoid

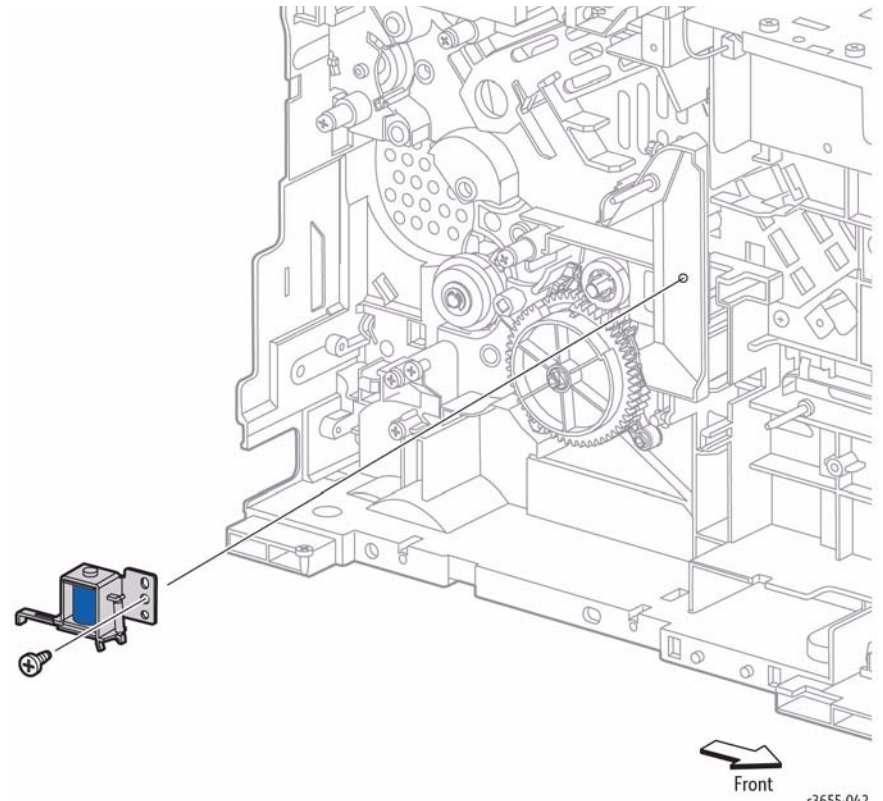

Figure 2 Remove the MSI Solenoid

11. Refer to Figure 2 to locate and remove 1 screw that secures the solenoid to the chassis.

REP 13.1.15 MSI Pick-up Holder Assembly

Parts List on PL 13.1 Item 15

Removal

WARNING

Switch off the electricity to the machine. Disconnect the power cord from the customer supply while performing tasks that do not need electricity. Electricity can cause death or injury. Moving parts can cause injury.

1. Remove all Trays.
2. Refer to Figure 1 to locate and release the clip that secures the pick-up flange to remove the assembly.

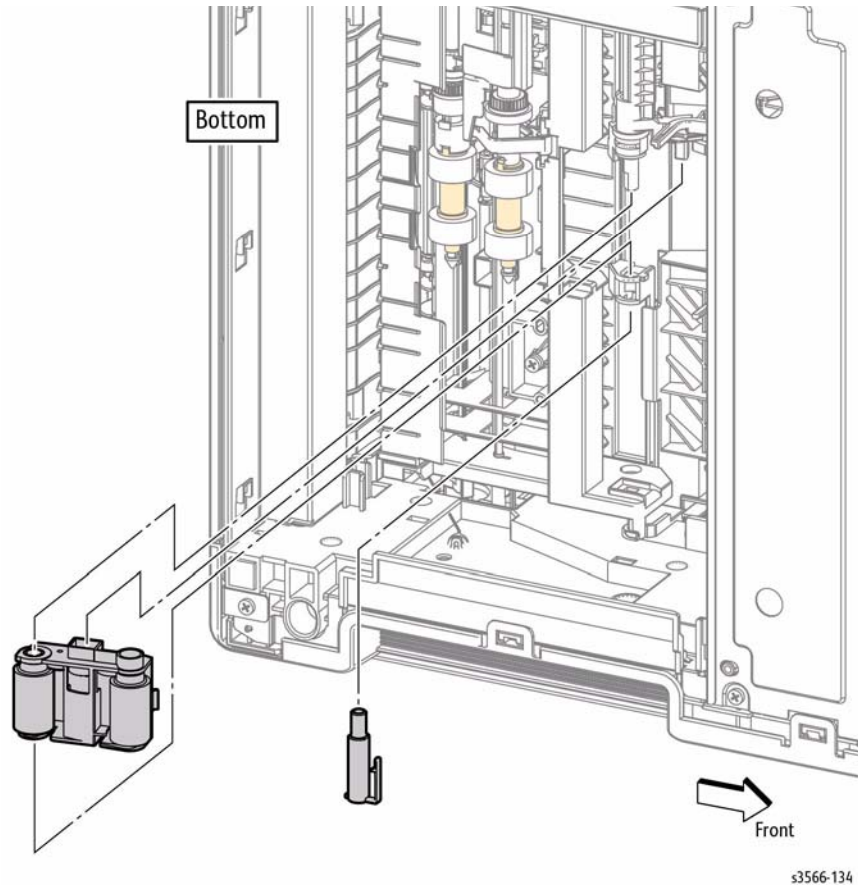

Figure 1 Remove the Pick-up Assembly

Replacement

Make sure the assembly engages the lift lever following replacement.

REP 13.1.97 Top Frame Assembly

Parts List on PL 13.1 Item 97

Removal

WARNING

Switch off the electricity to the machine. Disconnect the power cord from the customer supply while performing tasks that do not need electricity. Electricity can cause death or injury. Moving parts can cause injury.

CAUTION

Cover the Drum Cartridge after removal to prevent light exposure.

1. Open the Front Cover.
2. Remove the Drum Cartridge, REP 8.1.1.
3. Refer to Figure 1 to locate and release 4 clips that secure the Top Frame Assembly to the chassis.

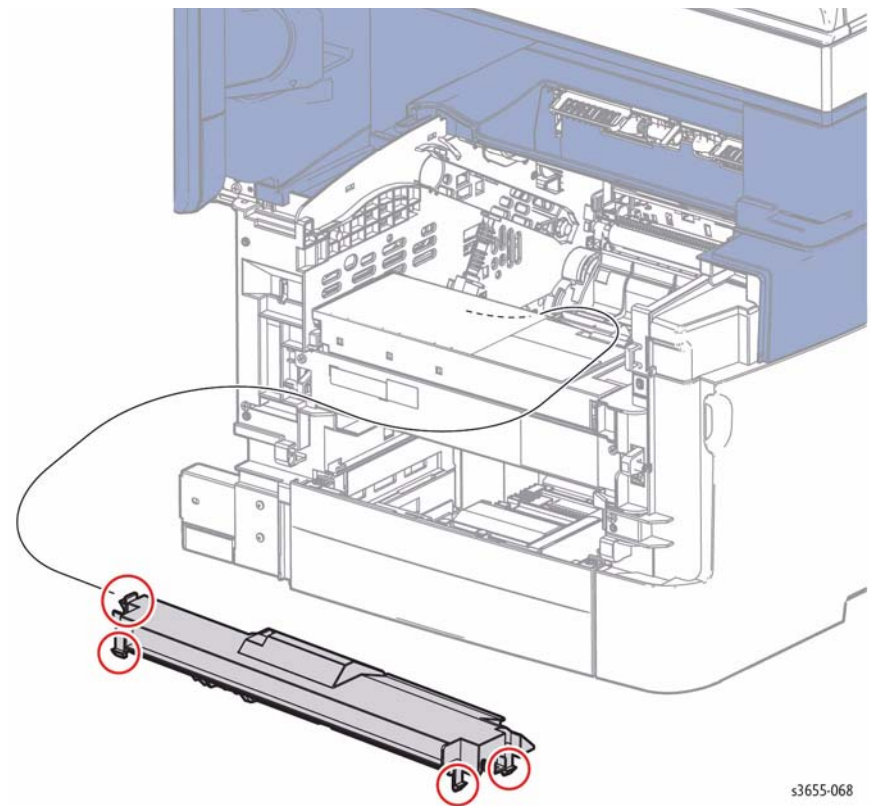

Figure 1 Remove the Top Frame Assembly

Replacement

Check operation of the No Paper Sensor Actuator following installation.

REP 13.2.9 Bypass Tray

Parts List on PL 13.2 Item 9

Removal

1. Open the Bypass Tray
2. Refer to Figure 1 and pull the Bypass Tray from the chassis.

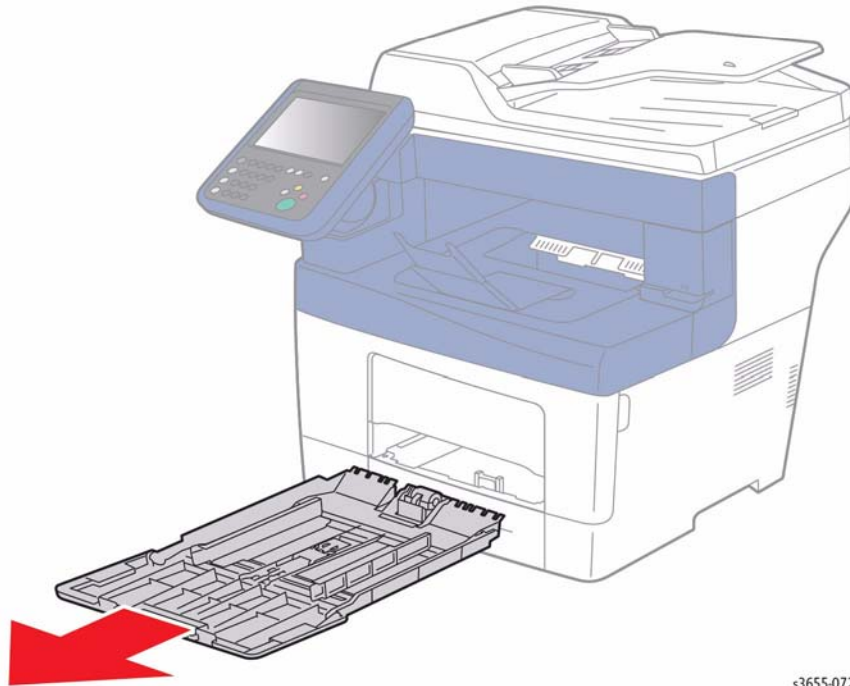

Figure 1 Remove the Bypass Tray

s3655-072

REP 13.2.98 MSI Retard Roller Assembly

Parts List on PL 13.2 Item 98

Removal

1. Remove the Bypass Tray, REP 13.2.9.
2. Refer to Figure 1 to locate and release the hook that secures the Retard Roller Assembly to the Bypass Tray, then remove the assembly by rotating it in the direction of the arrow.

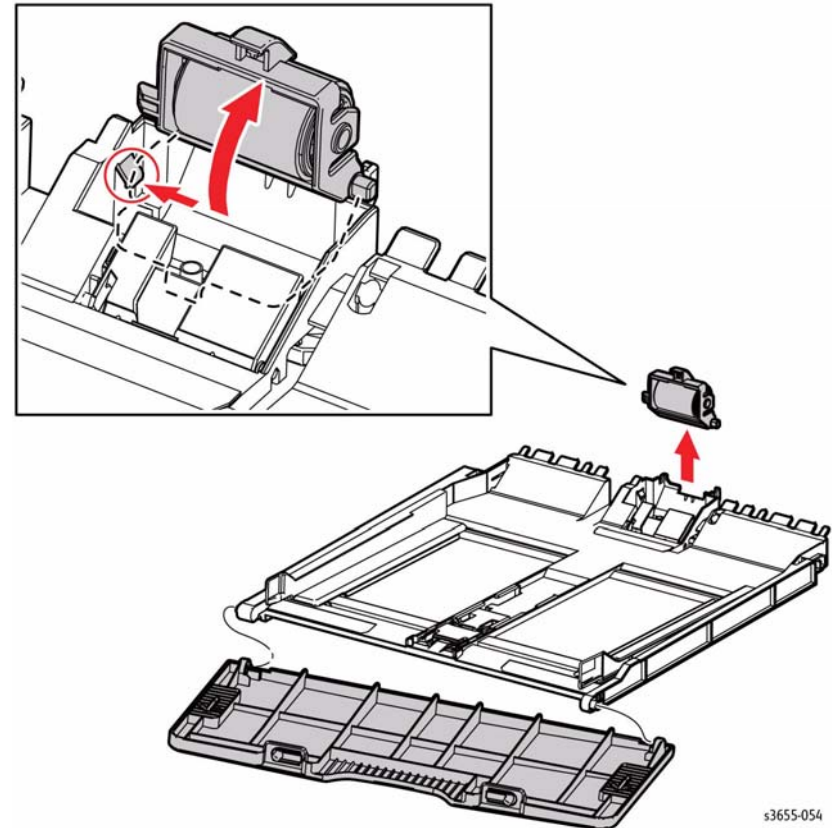

Figure 1 Remove the MSI Retard Roller Assembly

s3655-054

Replacement

1. Make sure the spring is positioned correctly before lowering the Retard Roller Assembly
2. Test the assembly once you have it installed.

REP 14.1.2 Duplex Roller Assembly

Parts List on PL 14.1 Item 2

Removal

WARNING

Switch off the electricity to the machine. Disconnect the power cord from the customer supply while performing tasks that do not need electricity. Electricity can cause death or injury. Moving parts can cause injury.

WARNING

Do not touch the Fuser while it is hot.

1. Open the Rear Cover.
2. Remove the Transfer Roller, REP 6.1.1.
3. Remove the Duplex Chute Assembly, REP 14.1.12.
4. Refer to Figure 1 to locate and release the bearing at each end of the roller shaft to remove the roller.

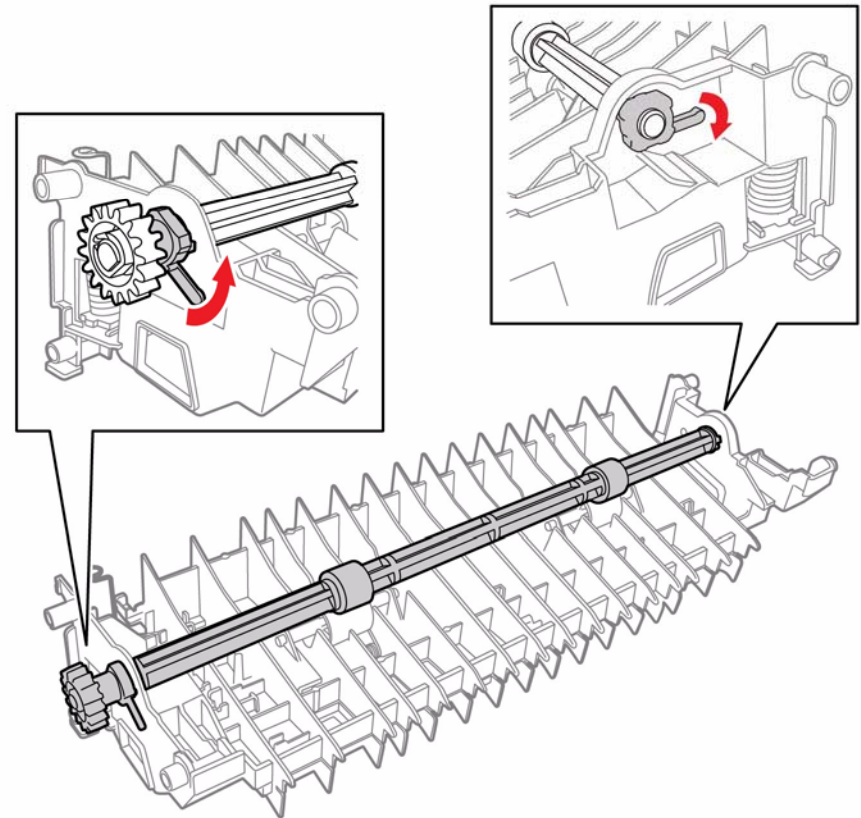

Figure 1 Remove the Duplex Roller

s3655-246

REP 14.1.12 Duplex Chute Assembly

Parts List on PL 14.1 Item 12

Removal

WARNING

Switch off the electricity to the machine. Disconnect the power cord from the customer supply while performing tasks that do not need electricity. Electricity can cause death or injury. Moving parts can cause injury.

WARNING

Do not touch the Fuser while it is hot.

1. Open the Rear Cover.
2. Remove the Transfer Roller, REP 6.1.1.
3. Refer to Figure 1 to locate and remove 1 screw (silver, tapping, 4mm) that secures 2 ground springs to the Rear Cover.

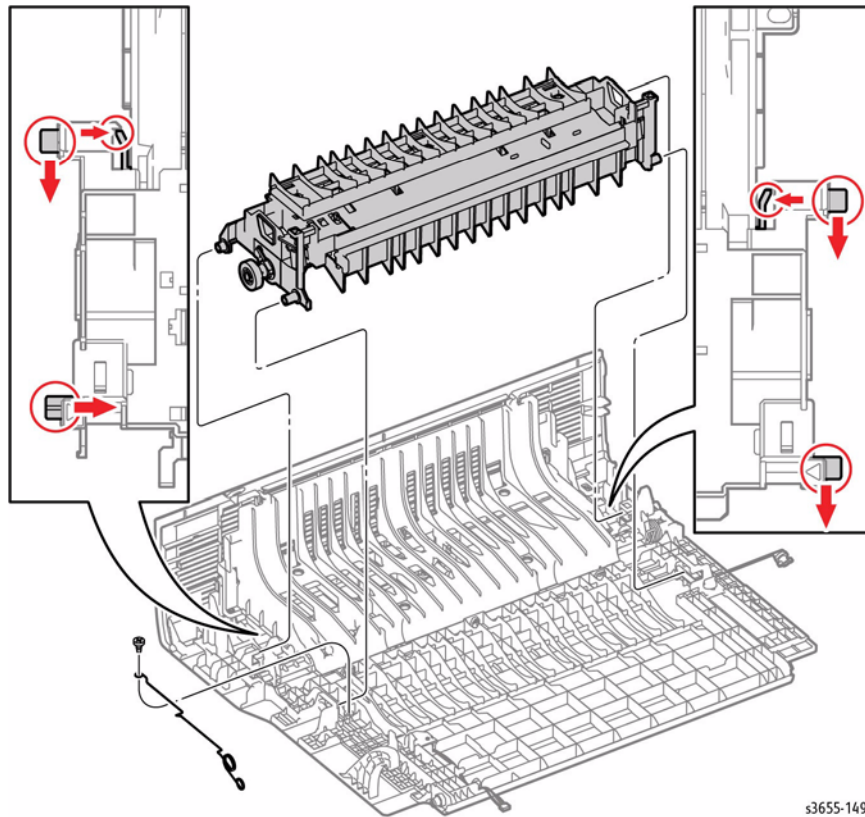

Figure 1 Remove the Duplex Chute Assembly

4. Release 2 clips that secure the Duplex Chute Assembly to the Rear Cover.

5. Rotate and slide the Duplex Chute Assembly to the left until the 4 bosses release.

Replacement

1. Install the Duplex Chute Assembly onto the Rear Cover.
2. Refer to Figure 2 to locate and secure the 2 grounding springs to the Rear Cover. Fasten the spring connecting to the chassis on top of the spring in the Rear Cover.

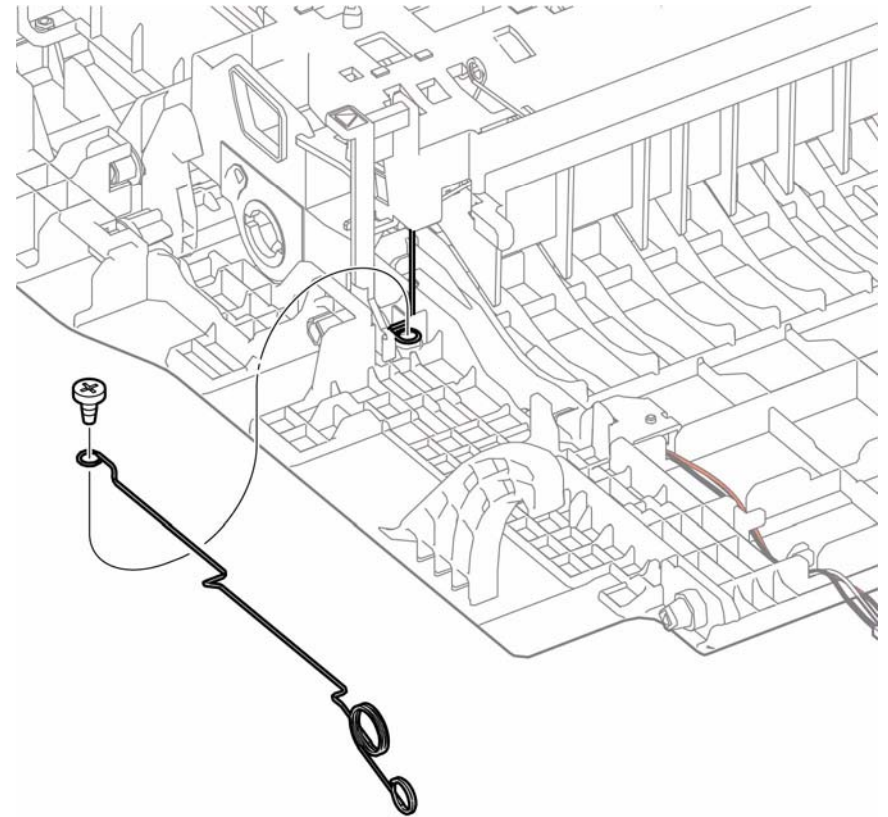

s3655-150

Figure 2 Replace Ground Springs

REP 15.1.6 Registration Assembly



Parts List on PL 15.1 Item 6

Removal

WARNING

Switch off the electricity to the machine. Disconnect the power cord from the customer supply while performing tasks that do not need electricity. Electricity can cause death or injury. Moving parts can cause injury.

WARNING

Do not touch the Fuser while it is hot.

CAUTION

Cover the Drum Cartridge after removal to prevent light exposure.

1. Open the Rear Cover. Release the Stopper Strap and hinge from the chassis and rest the Rear Cover on the work surface.
2. Remove the Fuser, REP 7.1.1.
3. Remove the Left Rear Cover, REP 19.2.2.
4. Remove, but do not disconnect, the Rear Interlock Switch Assembly, REP 15.1.97.
5. Open the Front Cover.
6. Remove the Drum Cartridge, REP 8.1.1, and Tray 1 Cassette,
7. Remove the Left UI Base Cover, REP 1.1.6.
8. Remove the Left Side Cover, REP 19.2.1.
9. Remove the ESS housing cover, REP 18.1.1.
10. Remove the ESS housing, REP 18.1.2.
11. Remove the Stapler Cover, REP 19.1.11 or Outer Right Cover, REP 19.1.13.
12. Remove the Right Side Cover, REP 19.1.10.
13. Remove the HVPS, REP 18.2.5.
14. Remove the Registration Sensor Shutters, REP 15.2.14.
15. Remove the Main Drive Assembly, REP 3.1.1.
16. Refer to Figure 1 to locate and release 4 hooks to remove the Top Frame Assembly. Release 3 hooks to remove the MCU Board cover, then disconnect the Transport Assembly from the MCU Board and release the harnesses from the guides.

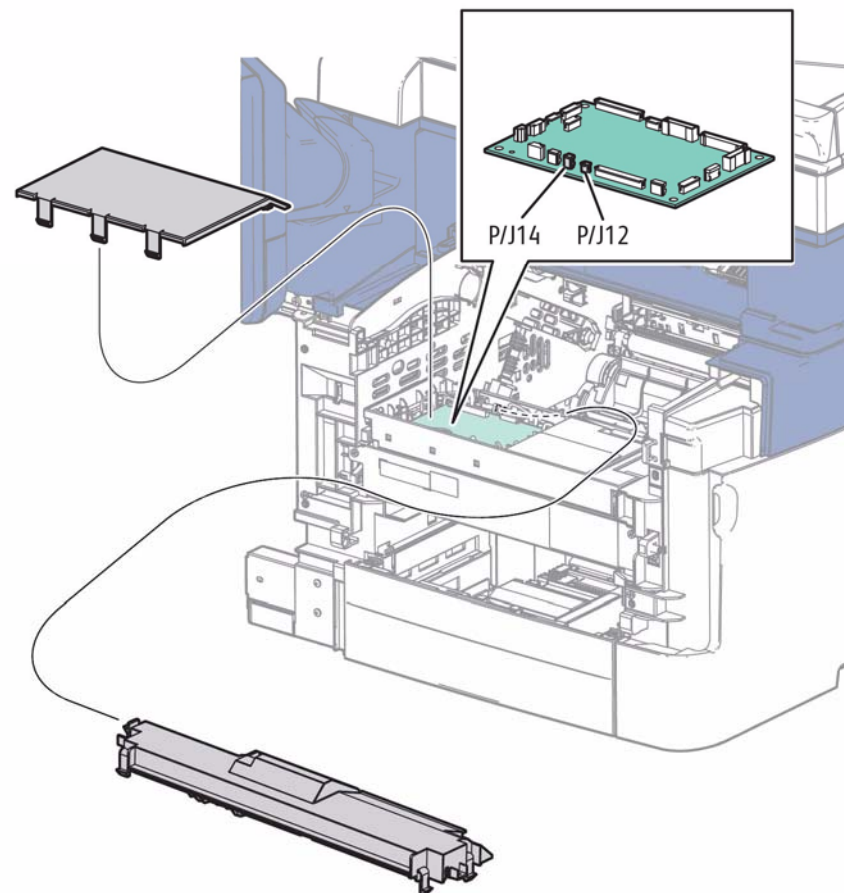

s3655-038

Figure 1 Disconnect the Transport Assembly

17. Refer to Figure 2 to locate and remove 1 screw (silver, tapping, 8mm) to release, but not disconnect, the MSI Feed Solenoid, then remove both Feed Gear segments.

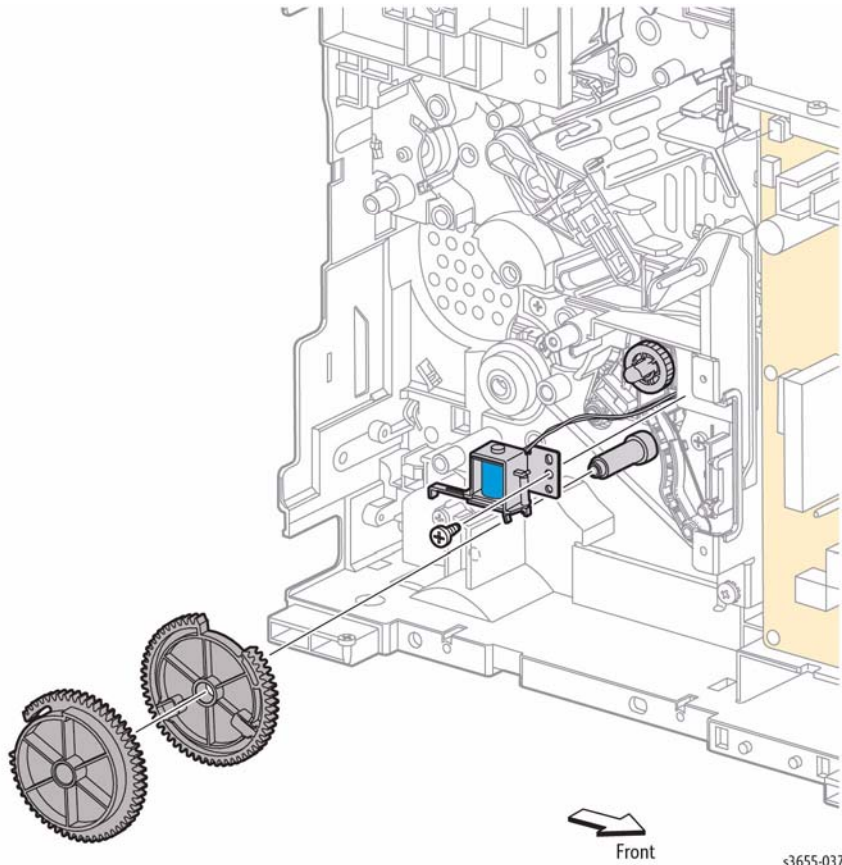

Figure 2 Remove the Feed Gear

18. Refer to Figure 3 to locate and release the feed spring from the lifter arm and remove the lifter and stopper arms from the printer's left side.

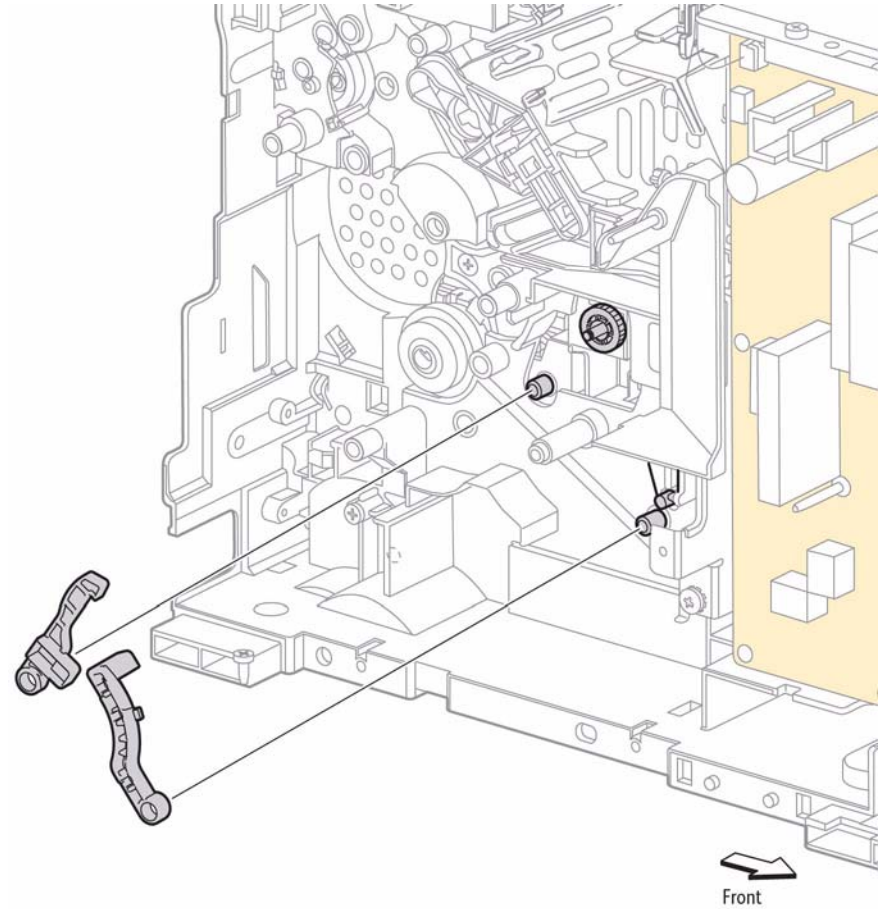

Figure 3 Remove the Lifter and Stopper Arms

19. Refer to Figure 4 to locate and remove 1 screw (silver, tapping, 8mm) that secures the ground strap.

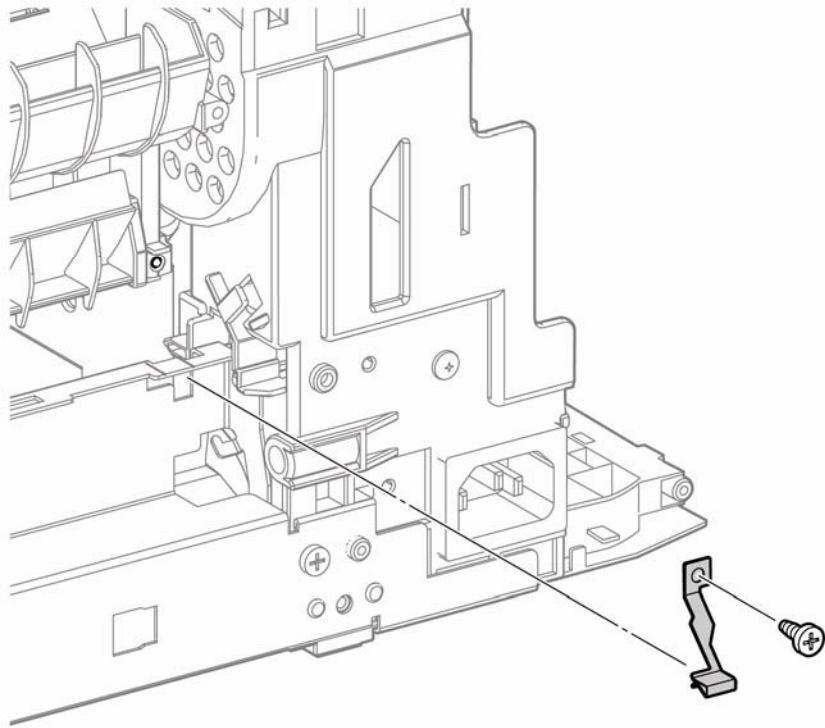

Figure 4 Remove the Ground Strap



20. Refer to Figure 5 to locate and remove 3 screws (silver, tapping, 8mm), then rotate the Transport Assembly from the left CW into the cavity of the machine to clear gears on the right side of the assembly. Next, lift the Transport Assembly towards the front to remove.

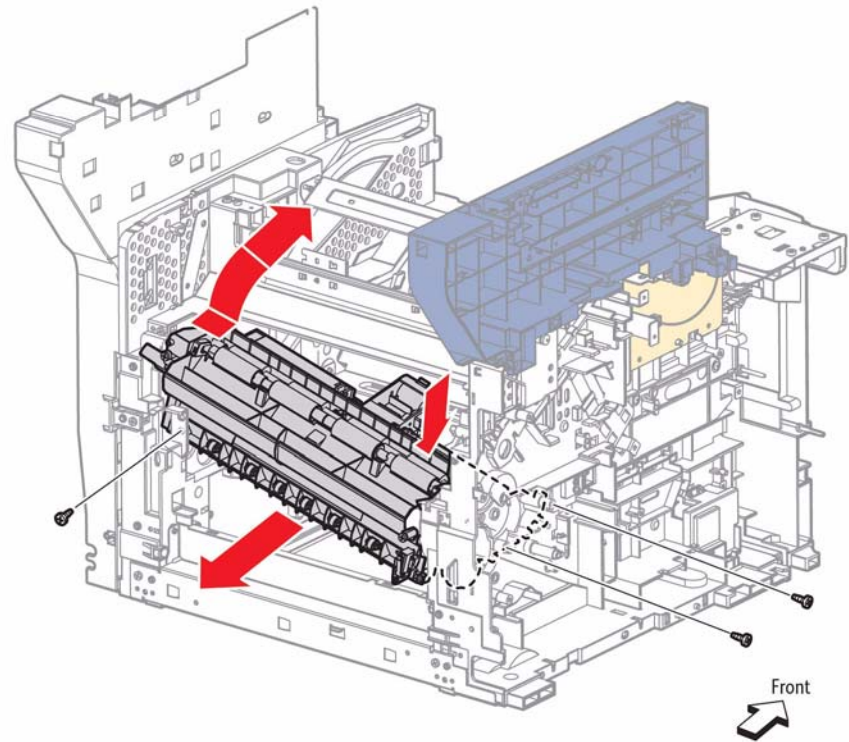

Figure 5 Remove the Transport Assembly

s3655-043

Replacement

1. Refer to Figure 6 to locate the registration actuator openings in the chassis. Carefully inset the actuators into the openings during installation. Seat the Transport Assembly boss on the chassis support as shown.

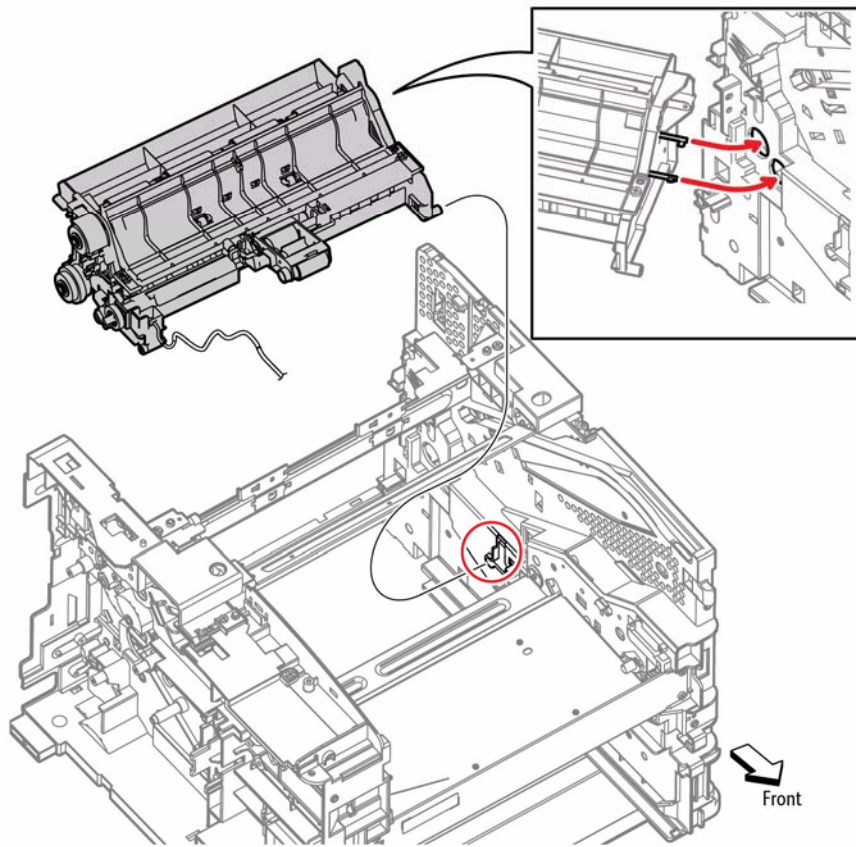

Figure 6 Install the Transport Assembly

s3655-044

2. Refer to Figure 7 when installing the MSI stopper arm. Position the Pick-up Holder Assembly as shown to properly engage the arm.

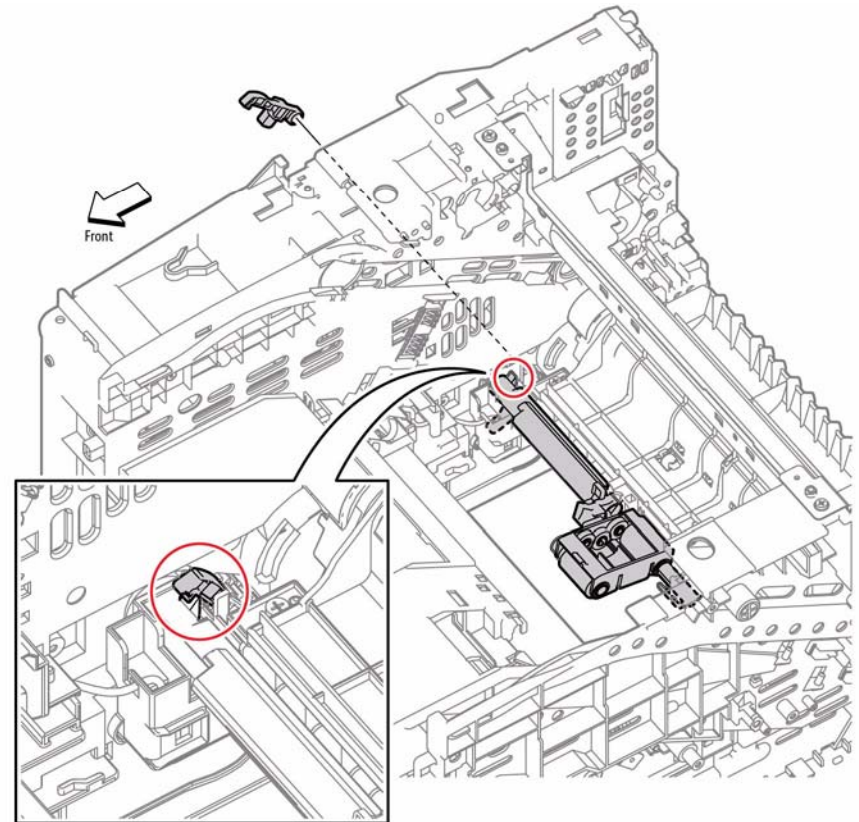

Figure 7 Install the Stopper Arm

s3655-136

3. Refer to Figure 8 to properly install the feed spring to the MSI lifter arm.

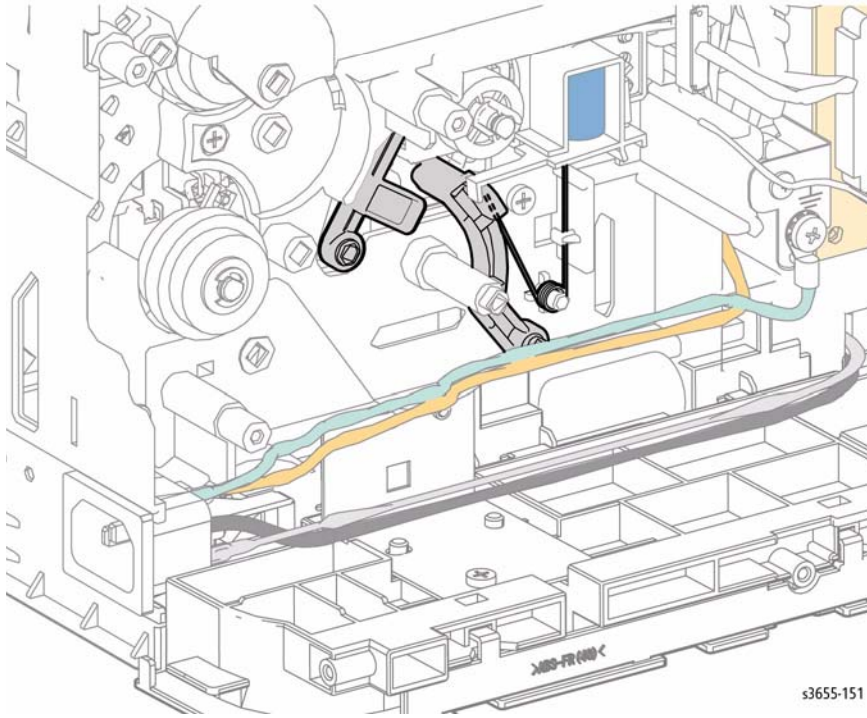

Figure 8 Install the Lifter Arm and Spring

4. Refer to Figure 9 to assemble the feed gear.

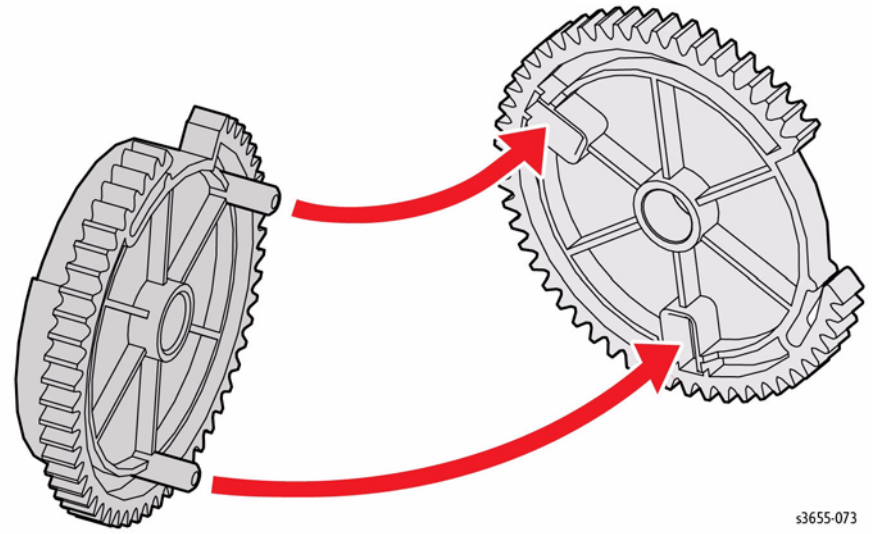

Figure 9 Assemble the Feed Gear

5. Refer to Figure 10 when installing the feed gear. Check the actuator properly engages the feed gear.

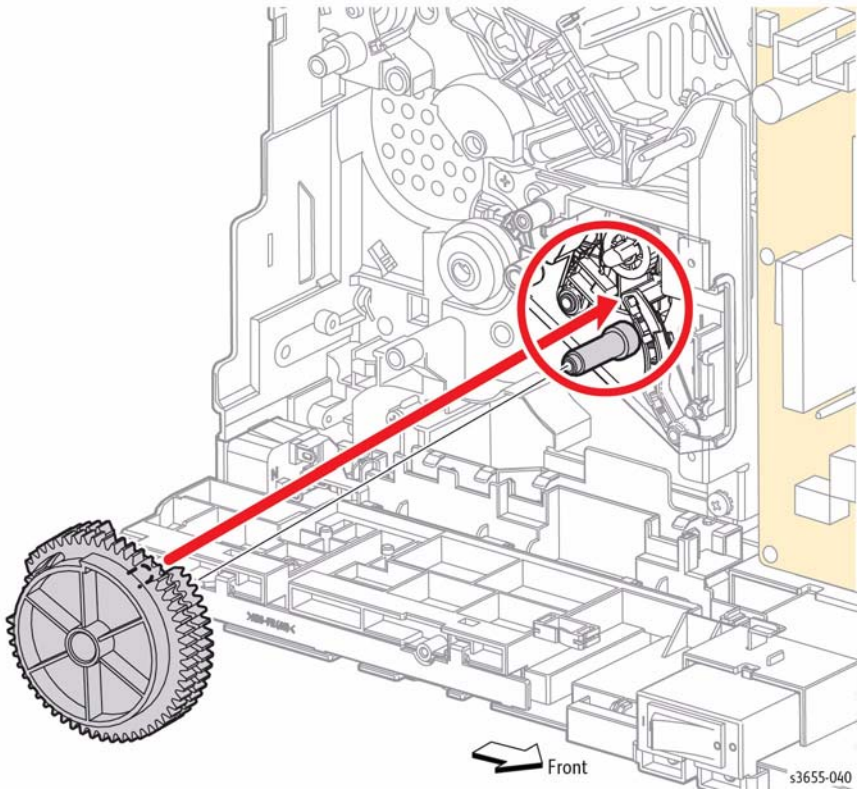

Figure 10 Install the Feed Gear

6. Refer to Figure 11 when installing the Top Frame Assembly. Check the No Paper Sensor Actuator passes through the hole in the chassis.

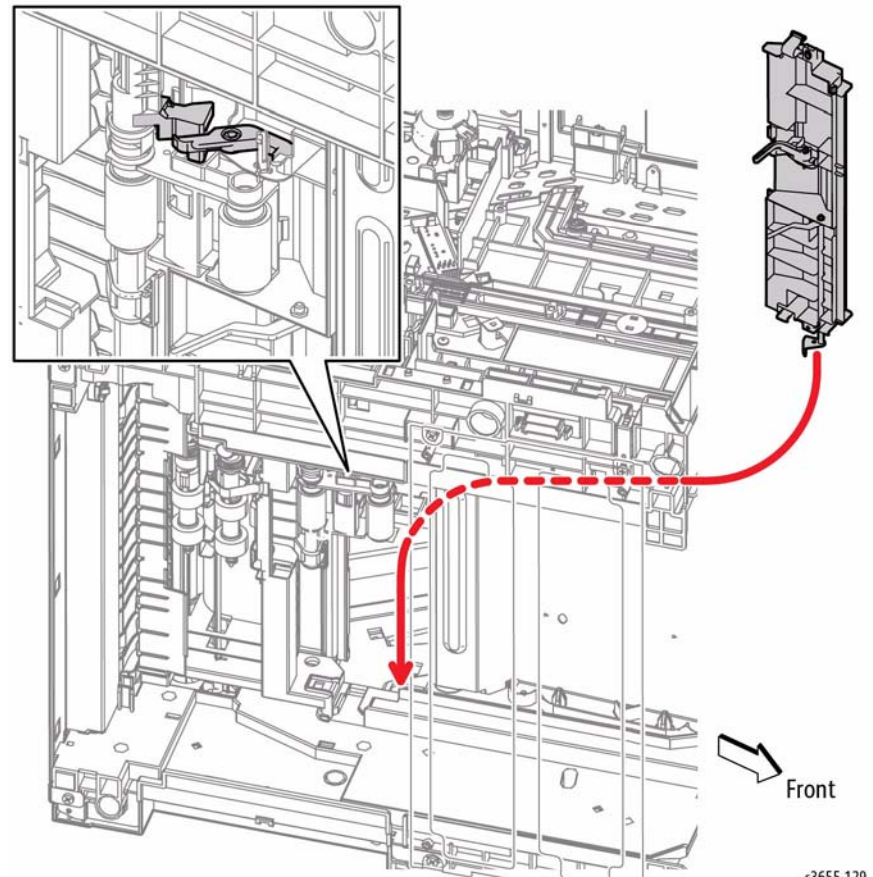

Figure 11 Install the Top Frame Assembly

REP 15.1.11 Tray 1 Stopper

Parts List on PL 15.1 Item 11

Removal

WARNING

Switch off the electricity to the machine. Disconnect the power cord from the customer supply while performing tasks that do not need electricity. Electricity can cause death or injury. Moving parts can cause injury.

WARNING

Do not touch the Fuser while it is hot.

1. Remove Tray 1.
2. Open the Rear Cover, release the stopper strap and hinge clip from the chassis and rest the Rear Cover Assembly on the work surface.
3. Remove, but do not disconnect, the Rear Interlock Switch Assembly, REP 15.1.97.
4. Refer to Figure 1 to locate and remove 1 screw (silver, tapping, 8mm) that secures the ground plate.

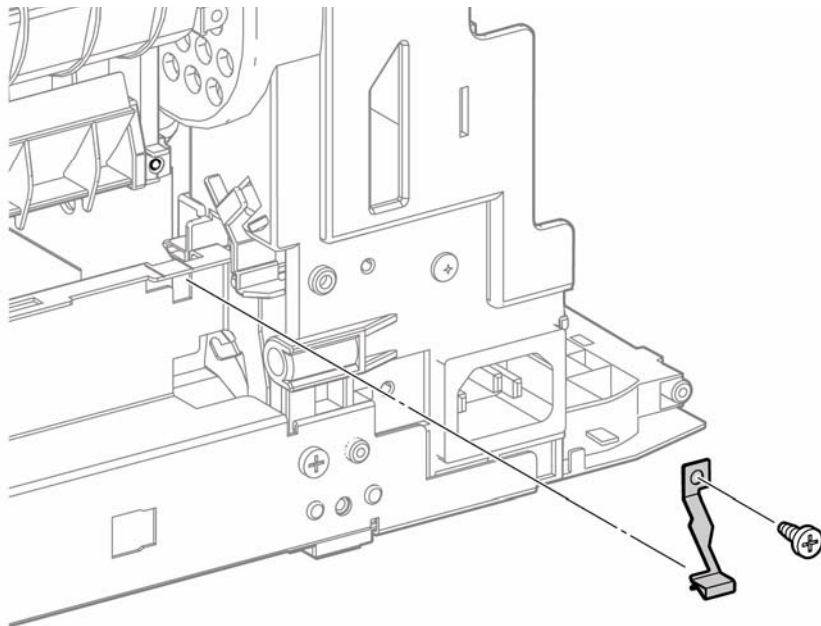

Figure 1 Remove the Ground Strap

5. Refer to Figure 2 to locate and release the bottom clip then rotate the Tray 1 Stopper inward to remove.

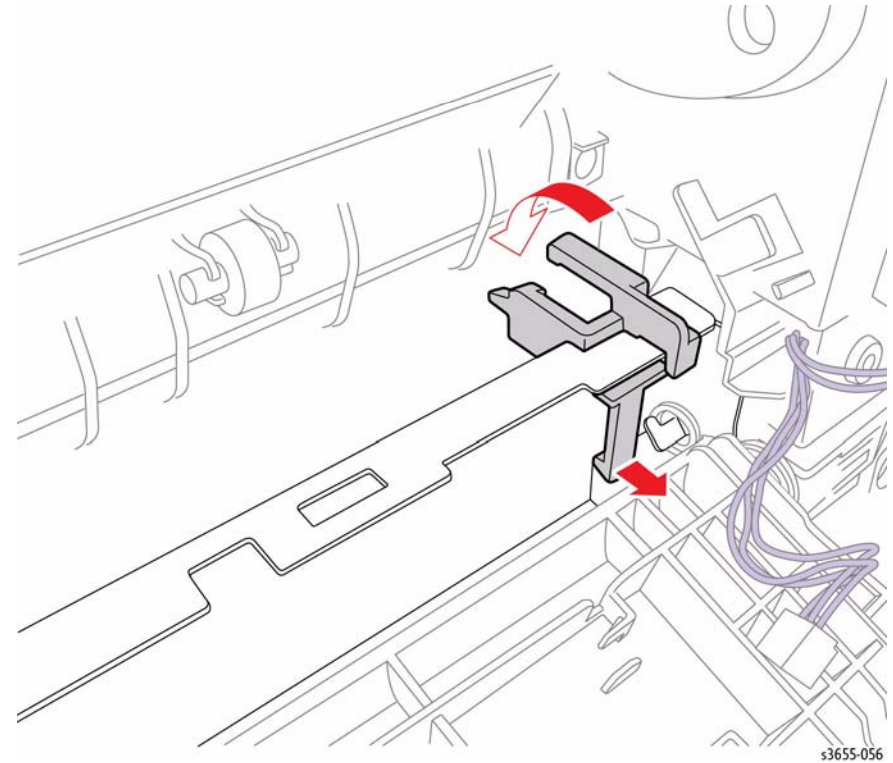

Figure 2 Remove the Tray 1 Stopper

REP 15.1.97 Rear Interlock Switch Assembly

Parts List on PL 15.1 Item 97

Removal

WARNING

Switch off the electricity to the machine. Disconnect the power cord from the customer supply while performing tasks that do not need electricity. Electricity can cause death or injury. Moving parts can cause injury.

WARNING

Do not touch the Fuser while it is hot.

1. Open the Rear Cover, release the Stopper Strap and hinge from the chassis and rest the Rear Cover Assembly on the work surface.
2. Remove the Left Rear Cover, REP 19.2.2.
3. Open the Front Cover.
4. Remove the Left UI Base Cover, REP 1.1.6.
5. Remove the Left Side Cover, REP 19.2.1.
6. Remove the ESS housing cover, REP 18.1.1.
7. Remove the ESS housing, REP 18.1.2.
8. Refer to Figure 1 to locate and disconnect the Fuser from the LVPS, then release 1 hook at top that secures the fuser harness guide.

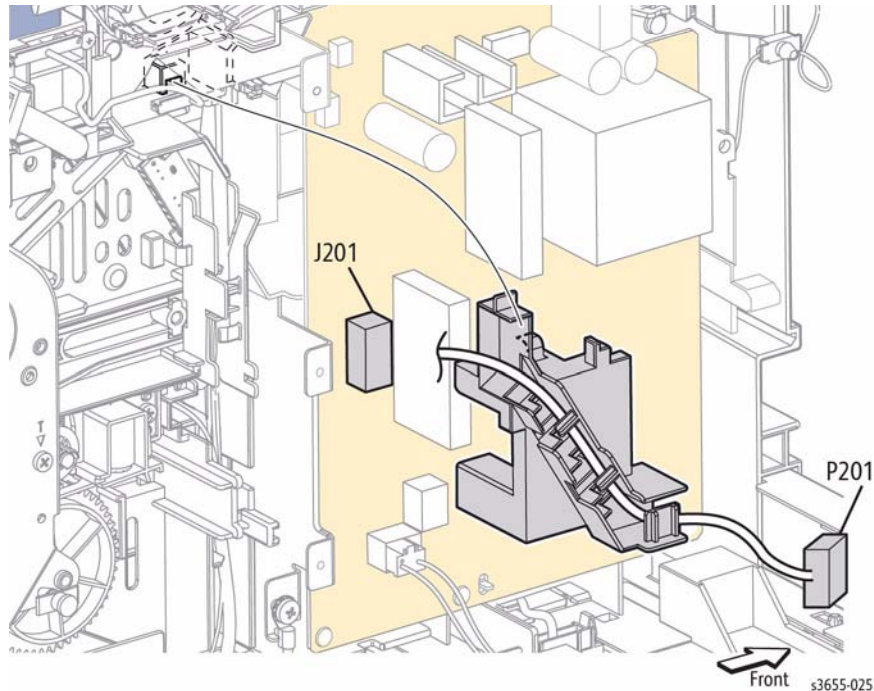

Figure 1 Release the Fuser Harness Guide

9. Release 1 hook at the top of the connector cover, to access and remove the Rear Fan harness from the switch assembly.
10. Refer to Figure 2 to locate and remove 1 screw (silver, tapping, 8mm), release 2 bottom hooks, and 1 boss at left end to release the assembly from the chassis.

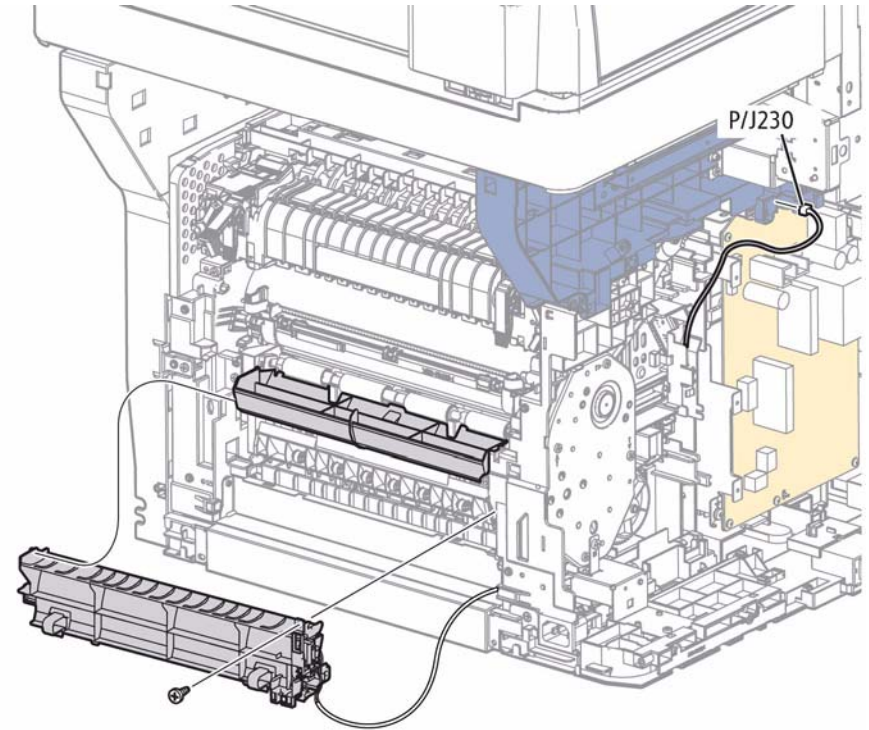

Figure 2 Remove the Rear Interlock Assembly

11. Refer to Figure 2 to locate and disconnect the Rear Interlock Switch Assembly. Release the switch harness from the harness guides along the LVPS and under the Main Drive Assembly to remove the assembly.

REP 15.2.4 Registration Clutch

Parts List on PL 15.2 Item 4

Removal

WARNING

Switch off the electricity to the machine. Disconnect the power cord from the customer supply while performing tasks that do not need electricity. Electricity can cause death or injury. Moving parts can cause injury.

WARNING

Do not touch the Fuser while it is hot.

1. Remove the Transport Assembly, REP 15.1.6.
2. Refer to Figure 1 to locate and remove the E-ring that secures the clutch to the Transport Assembly.

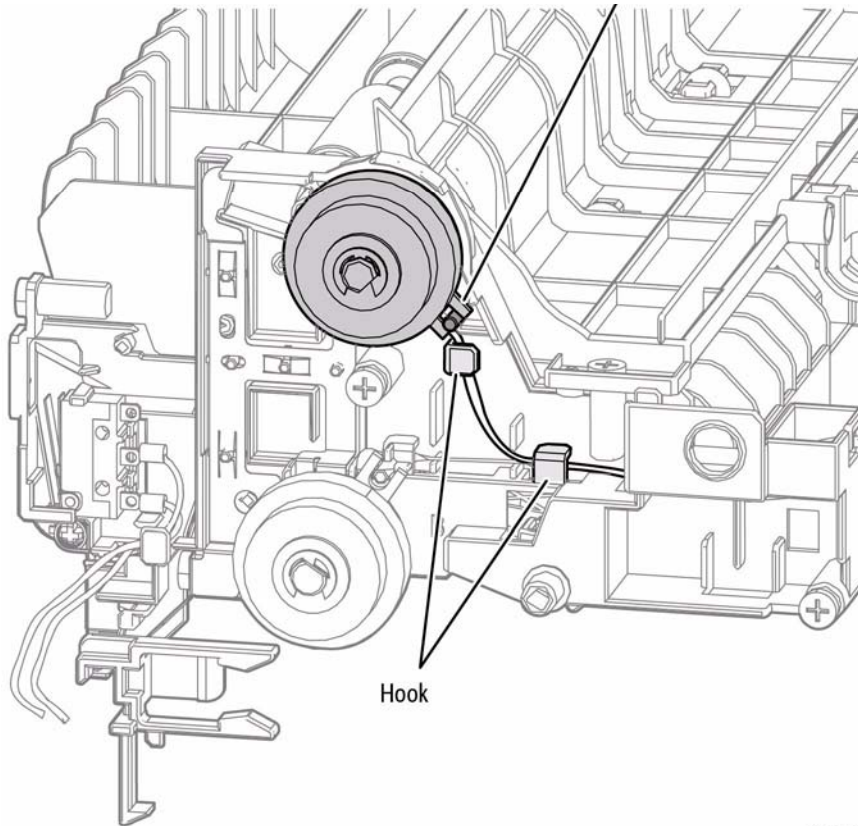

s3655-152

Figure 1 Remove the Registration Clutch

3. Release the Registration Clutch harness from the hooks to remove the clutch.

REP 15.2.6 Rubber Registration Roller

Parts List on PL 15.2 Item 6

Removal

WARNING

Switch off the electricity to the machine. Disconnect the power cord from the customer supply while performing tasks that do not need electricity. Electricity can cause death or injury. Moving parts can cause injury.

WARNING

Do not touch the Fuser while it is hot.

1. Remove the Transport Assembly, REP 15.1.6.
2. Refer to Figure 1 to locate and remove the MSI Pick-up Assembly.

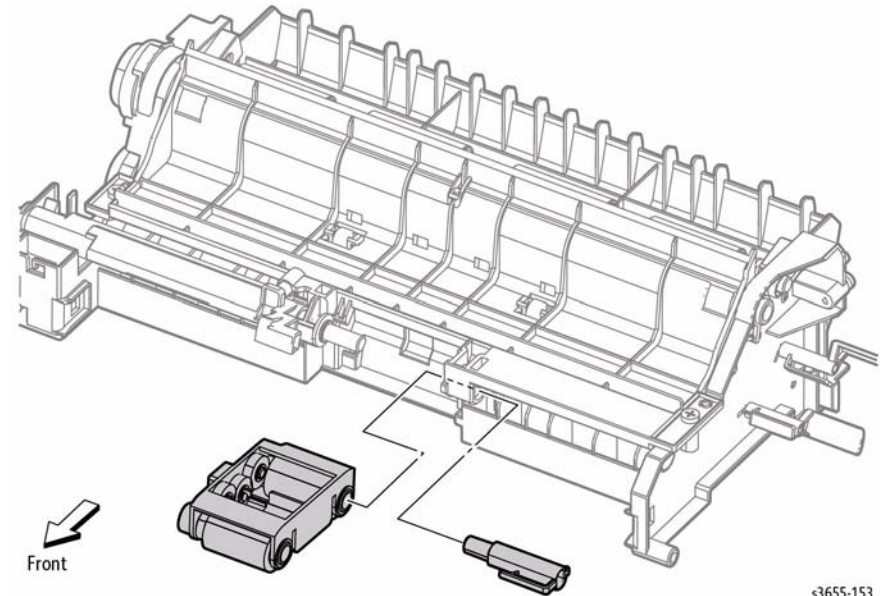

s3655-153

Figure 1 Remove the MSI Pick-up Assembly

3. Refer to Figure 2 to locate and remove the registration spring and feed bearing, then remove the MSI lifter lever and shaft.

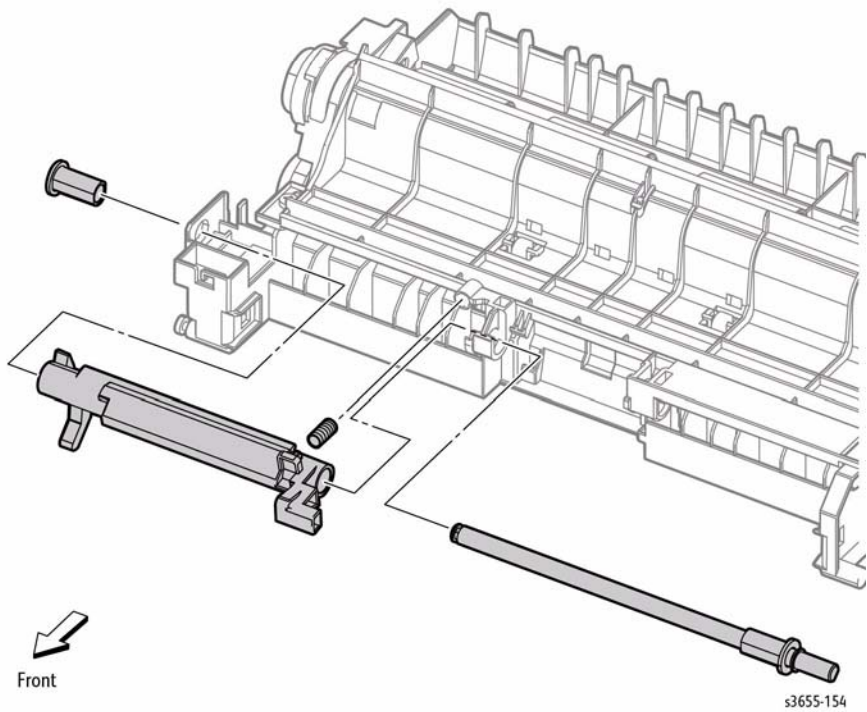

Figure 2 Remove the MSI Lifter Lever and Shaft

4. Refer to Figure 3 to locate and remove 2 screws (silver, tapping, 8mm) that secure the registration chute.

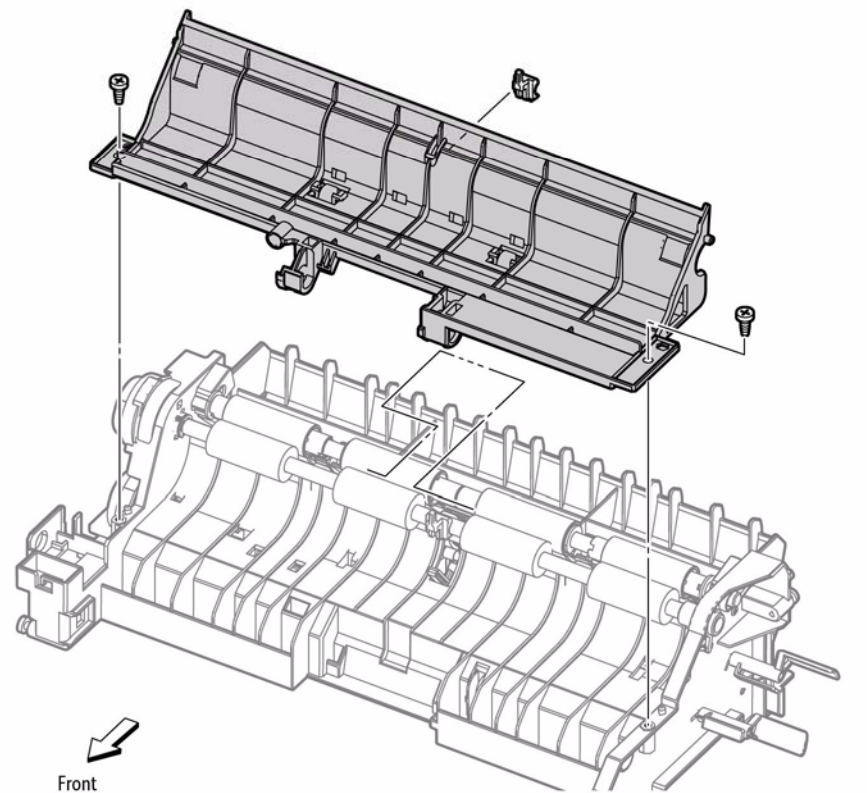

Figure 3 Remove the Registration Chute

5. Remove, but do not disconnect, the Registration Clutch, REP 15.2.4.
6. Refer to Figure 4 to locate, lift, and rotate the registration shaft bearings to remove.

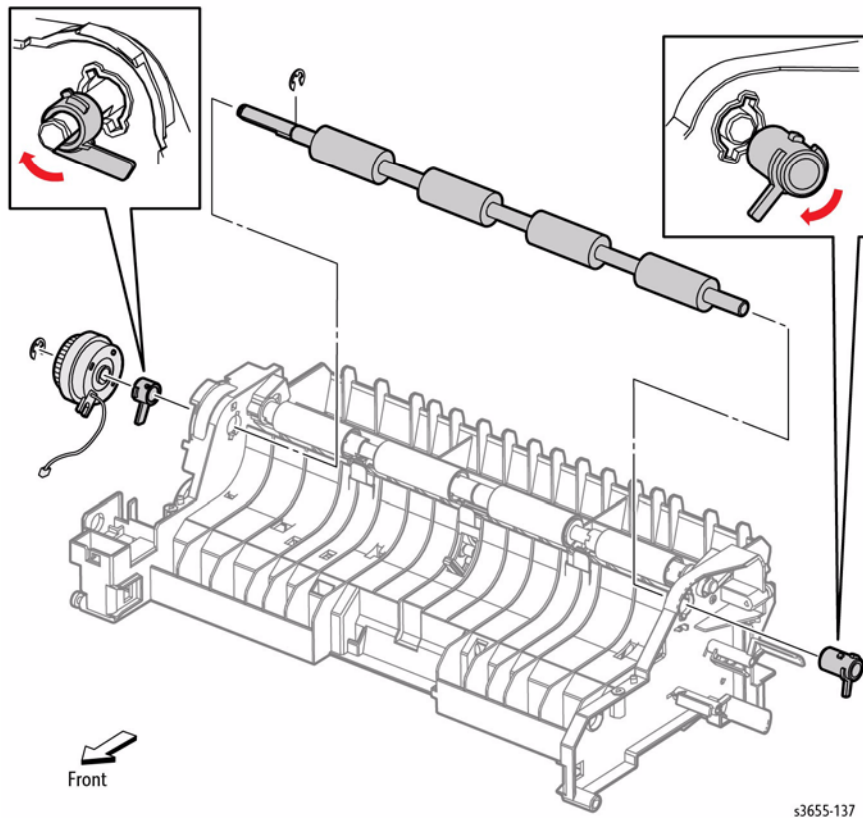

Figure 4 Remove the Rubber Registration Roller

7. Release the tension springs from the plastic registration roller shaft.
8. Remove the E-ring on the Rubber Registration Roller shaft, then slide the shaft to the left to remove the shaft from the Transport Assembly.

Replacement

Refer to Figure 5 to install the plastic registration roller tension spring with the extra coil (right side as shown) facing the roller.

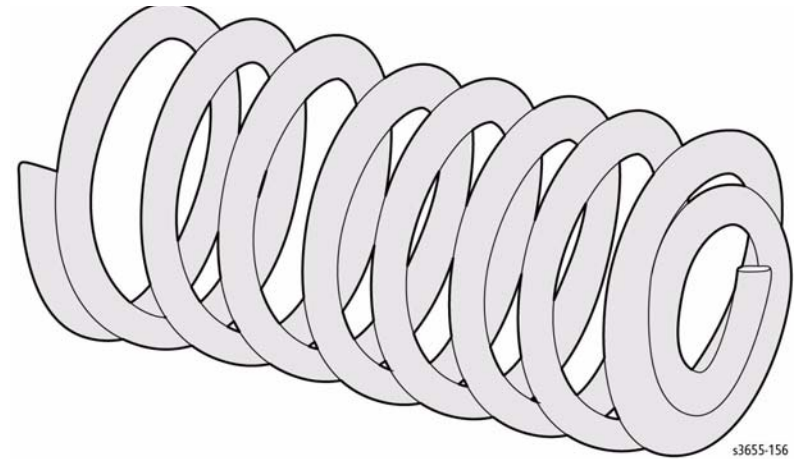

Figure 5 Registration Roller Tension Spring

REP 15.2.14 Registration Sensor Shutter

Parts List on PL 15.2 Item 14

Removal

WARNING

Switch off the electricity to the machine. Disconnect the power cord from the customer supply while performing tasks that do not need electricity. Electricity can cause death or injury. Moving parts can cause injury.

1. Open the Front Cover.
2. Open the Rear Cover.
3. Remove the Stapler Cover, REP 19.1.11 or Outer Right Cover, REP 19.1.13.
4. Remove the Right Side Cover, REP 19.1.10.
5. Remove the HVPS, REP 18.2.5.
6. Refer to Figure 1 to locate and release the hooks that secure the Sensor Shutters to the Transport Assembly.

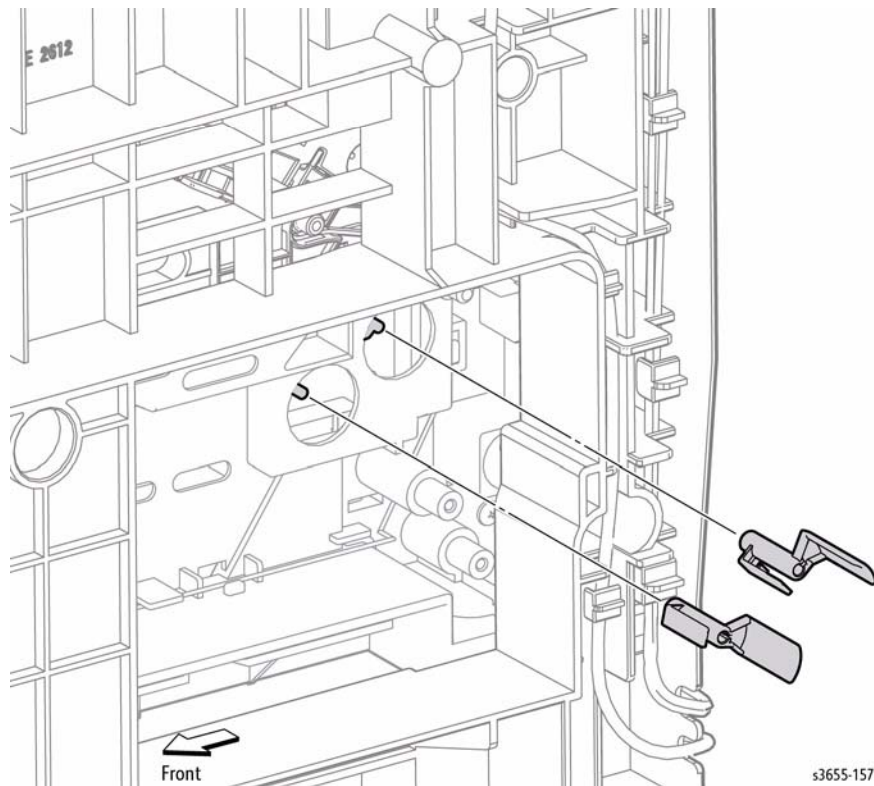

Figure 1 Remove the Sensor Shutters

REP 15.2.16 Feed Clutch

Parts List on PL 15.2 Item 16

Removal

WARNING

Switch off the electricity to the machine. Disconnect the power cord from the customer supply while performing tasks that do not need electricity. Electricity can cause death or injury. Moving parts can cause injury.

WARNING

Do not touch the Fuser while it is hot.

1. Remove the Transport Assembly, REP 15.1.6.
2. Refer to Figure 1 to locate and remove the E-ring that secures the Feed Clutch to the Transport Assembly.

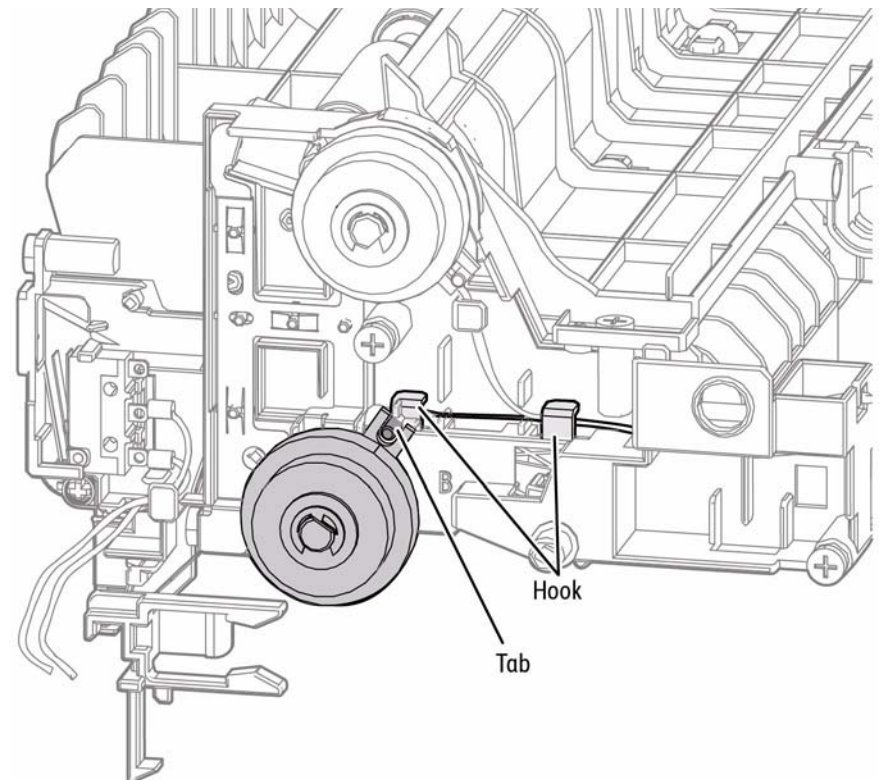

Figure 1 Remove the Feed Clutch

3. Release the Feed Clutch harness from the hook to remove the clutch.

REP 17.1.1 Exit Sensor

Parts List on PL 17.1 Item 1

Removal

WARNING

Switch off the electricity to the machine. Disconnect the power cord from the customer supply while performing tasks that do not need electricity. Electricity can cause death or injury. Moving parts can cause injury.

WARNING

Do not touch the Fuser while it is hot.

CAUTION

Cover the Drum Cartridge after removal to prevent light exposure.

1. Remove the Exit Chute Assembly, REP 17.1.99.
2. Refer to Figure 1 to locate and release the hooks that secure the Exit Sensor to the Exit Chute Assembly.

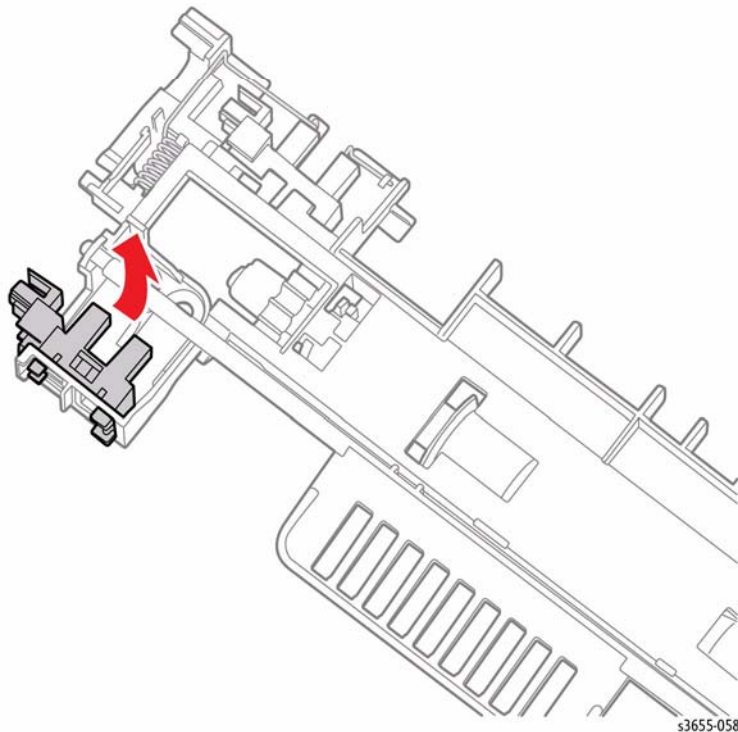

Figure 1 Remove the Exit Sensor

REP 17.1.5 Exit Roller

Parts List on PL 17.1 Item 5

Removal

WARNING

Switch off the electricity to the machine. Disconnect the power cord from the customer supply while performing tasks that do not need electricity. Electricity can cause death or injury. Moving parts can cause injury.

WARNING

Do not touch the Fuser while it is hot.

1. Remove the Exit Chute Assembly, REP 17.1.99.
2. Refer to Figure 1 to locate and remove the exit gear from the Exit Roller shaft, then release the shaft bearings to remove the Exit Roller from the Exit Chute Assembly.

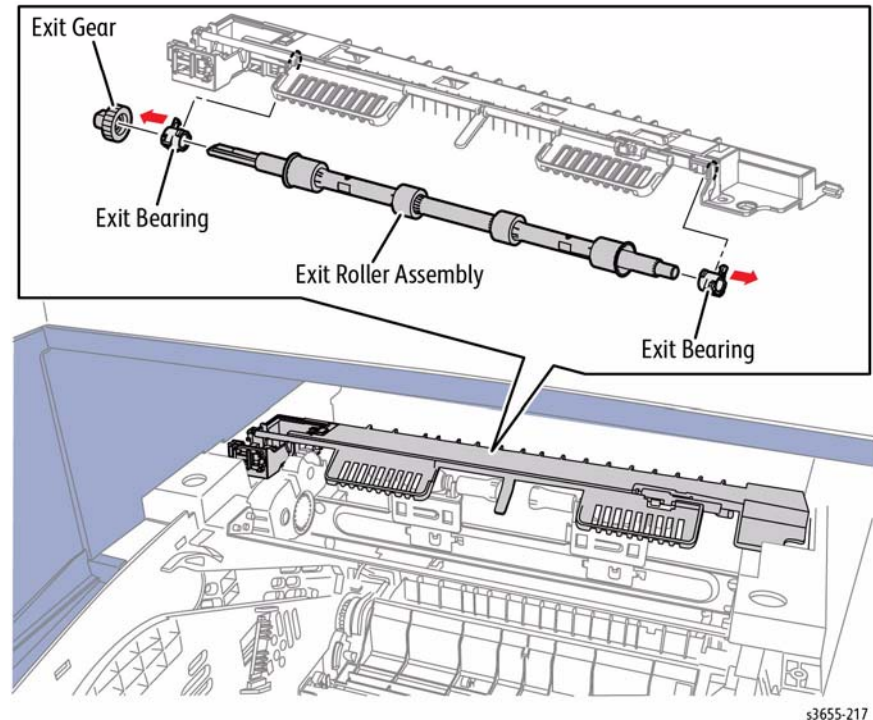

Figure 1 Remove the Exit Roller

REP 17.1.6 Pinch Rollers

Parts List on PL 17.1 Item 6, PL 17.1 Item 7

Removal

WARNING

Switch off the electricity to the machine. Disconnect the power cord from the customer supply while performing tasks that do not need electricity. Electricity can cause death or injury. Moving parts can cause injury.

WARNING

Do not touch the Fuser while it is hot.

1. Remove the Exit Chute Assembly, REP 17.1.99.
2. Refer to Figure 1 to remove the pinch rollers by carefully releasing the clips and moving them in the direction indicated.

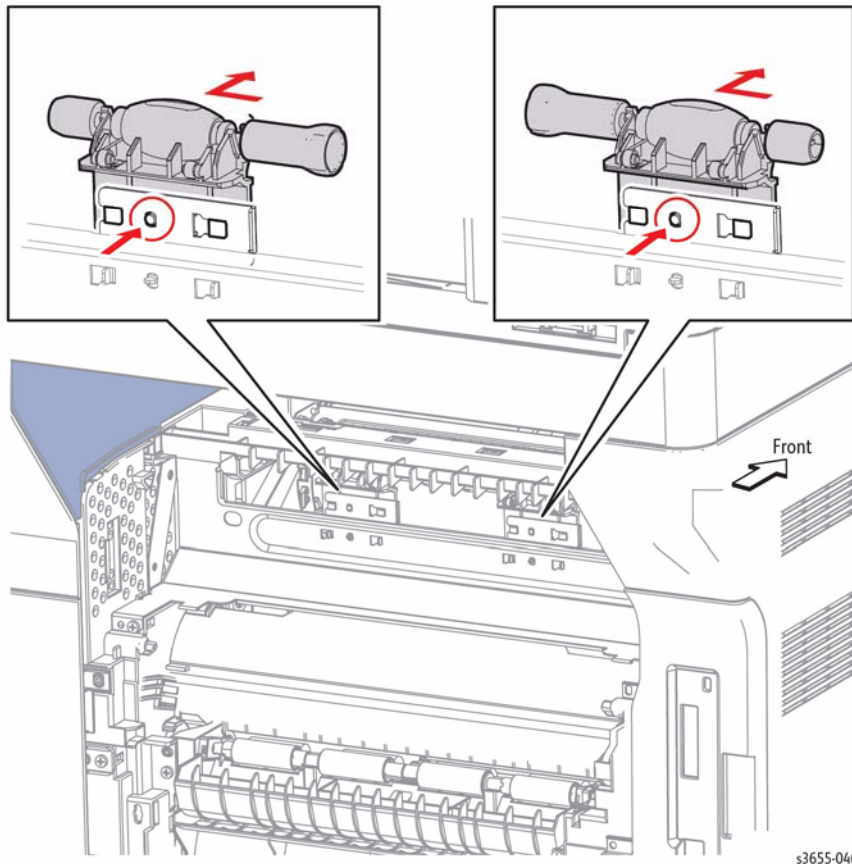

Figure 1 Remove the Pinch Rollers

REP 17.1.9 Full Stack Sensor

Parts List on PL 17.1 Item 9

Removal

WARNING

Switch off the electricity to the machine. Disconnect the power cord from the customer supply while performing tasks that do not need electricity. Electricity can cause death or injury. Moving parts can cause injury.

WARNING

Do not touch the Fuser while it is hot.

CAUTION

Cover the Drum Cartridge to prevent light exposure.

1. Remove the Exit Chute Assembly, REP 17.1.99.
2. Refer to Figure 1 to locate and release the hooks that secure the Full Stack Sensor to the Exit Chute Assembly.

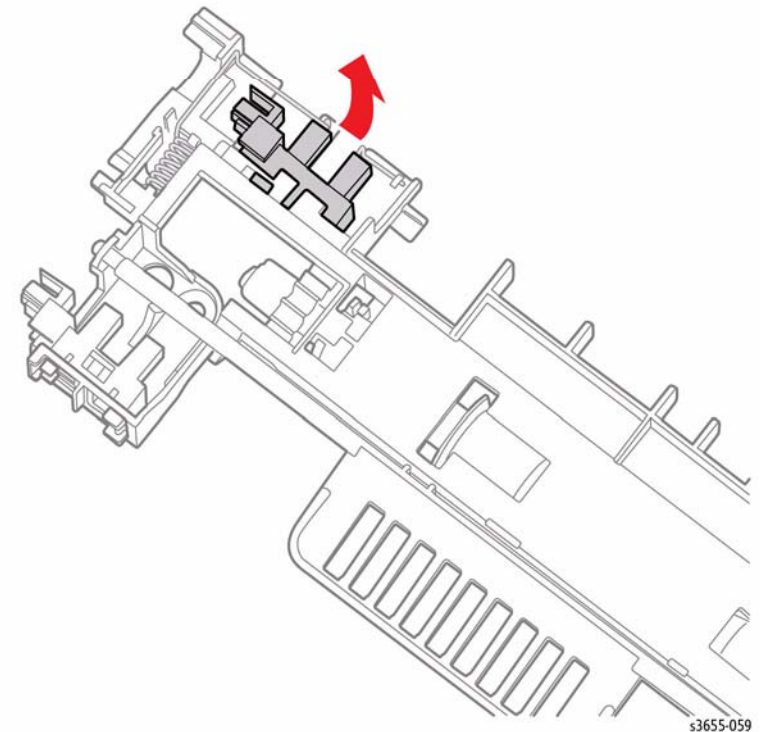

Figure 1 Remove the Full Stack Sensor

REP 17.1.99 Exit Chute Assembly

Parts List on PL 17.1 Item 99

Removal

WARNING

Switch off the electricity to the machine. Disconnect the power cord from the customer supply while performing tasks that do not need electricity. Electricity can cause death or injury. Moving parts can cause injury.

WARNING

Do not touch the Fuser while it is hot.

CAUTION

Cover the Drum Cartridge after removal to prevent light exposure.

1. Open the Rear Cover, release the Stopper Strap and hinge from the chassis and rest the Rear Cover Assembly on the work surface.
2. Remove the Fuser, REP 7.1.1.
3. Open the Front Cover.
4. Remove the Drum Cartridge, REP 8.1.1.
5. Remove the Stapler Cover, REP 19.1.11 or Outer Right Cover, REP 19.1.13.
6. Remove the Right Side Cover, REP 19.1.10.
7. Remove the Inner Right Cover, REP 19.1.14.
8. Remove the Left Rear Cover, REP 19.2.2.
9. Remove the Left Side Cover, REP 19.2.1.
10. Remove the ESS housing cover, REP 18.1.1.
11. Remove the ESS housing, REP 18.1.2.
12. Remove the Exit Cover Assembly, REP 19.1.99.
13. Refer to Figure 1 to locate and disconnect the Fuser from the LVPS, then release 1 hook at top that secures the fuser harness guide.

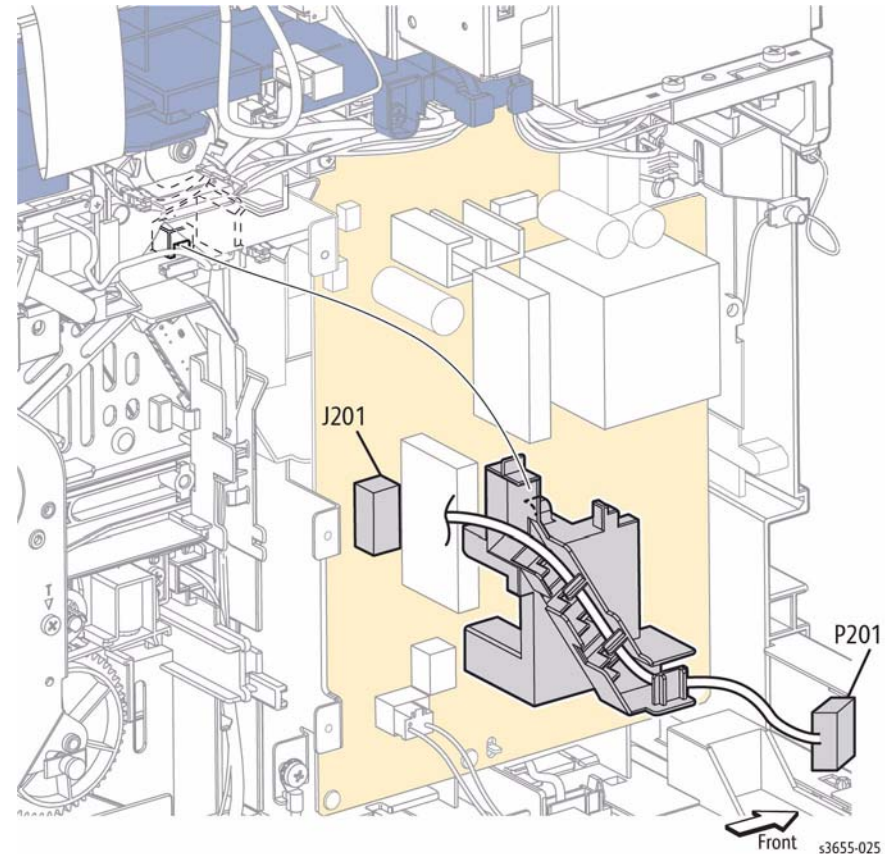

Figure 1 Release the Fuser Harness Guide

14. Release the Exit and Full Stack Sensor harnesses from the harness guide next to the LVPS to provide enough slack to disconnect the sensors at the Exit Chute Assembly.
15. Refer to Figure 2 to locate and remove 2 screws (silver, M3, 6mm) that secure the Exit Chute Assembly to the chassis.

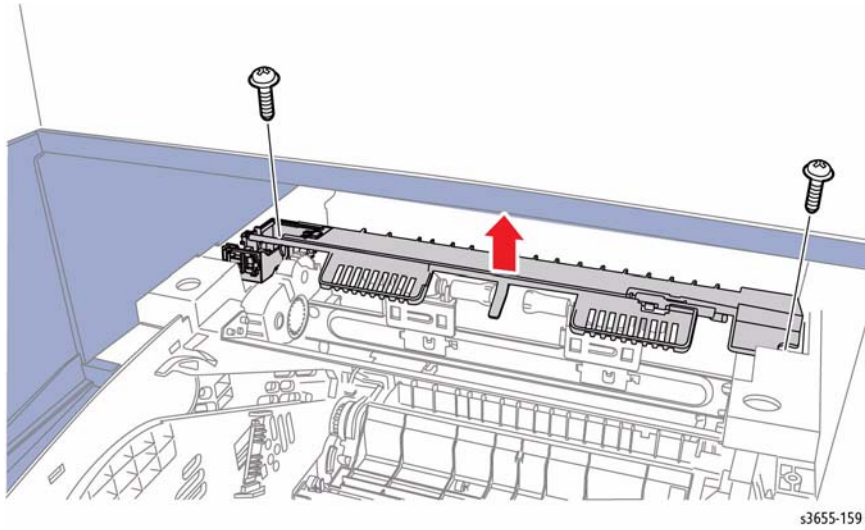

Figure 2 Remove the Exit Chute Assembly

16. Lift the chute in the direction of the arrow to disconnect the sensors.

REP 18.1.1 ESS Housing Cover

Parts List on PL 18.1 Item 1

Removal

WARNING

Switch off the electricity to the machine. Disconnect the power cord from the customer supply while performing tasks that do not need electricity. Electricity can cause death or injury. Moving parts can cause injury.

1. Open Front Cover.
2. Remove the Left UI Base Cover, REP 1.1.6.
3. Open Rear Cover.
4. Remove Left Rear Cover, REP 19.2.2.
5. Remove Left Side Cover, REP 19.2.1.
6. Disconnect the FAX Board from the ESS Board.
7. Disconnect the Side USB Assembly from the ESS Board and release the cable tie from the ESS housing cover.
8. Refer to Figure 1 to locate and remove 13 screws (silver, M3, 6mm) that secure the ESS housing cover.

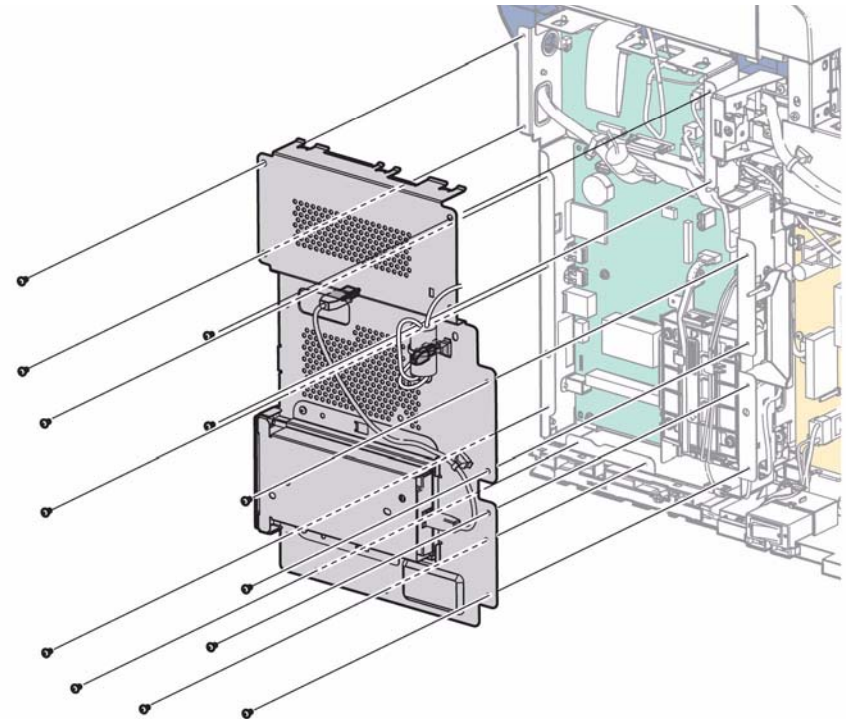

Figure 1 Remove ESS Housing Cover

REP 18.1.2 ESS Housing

Parts List on PL 18.1 Item 2

Removal

WARNING

Switch off the electricity to the machine. Disconnect the power cord from the customer supply while performing tasks that do not need electricity. Electricity can cause death or injury. Moving parts can cause injury.

WARNING

Do not touch the Fuser while it is hot.

1. Open the Rear Cover.
2. Remove the Left Rear Cover, REP 19.2.2.
3. Open the Front Cover.
4. Remove the Left UI Base Cover, REP 1.1.6.
5. Remove the Left Side Cover, REP 19.2.1.
6. Remove the ESS housing cover, REP 18.1.1.
7. Remove the Hard Drive, REP 18.1.97.
8. Remove the ESS Board, REP 18.1.98.
9. Remove the IIT Control Board, REP 18.1.4.
10. Refer to Figure 1 to locate and release the harness clamps from harnesses routed through the ESS housing.

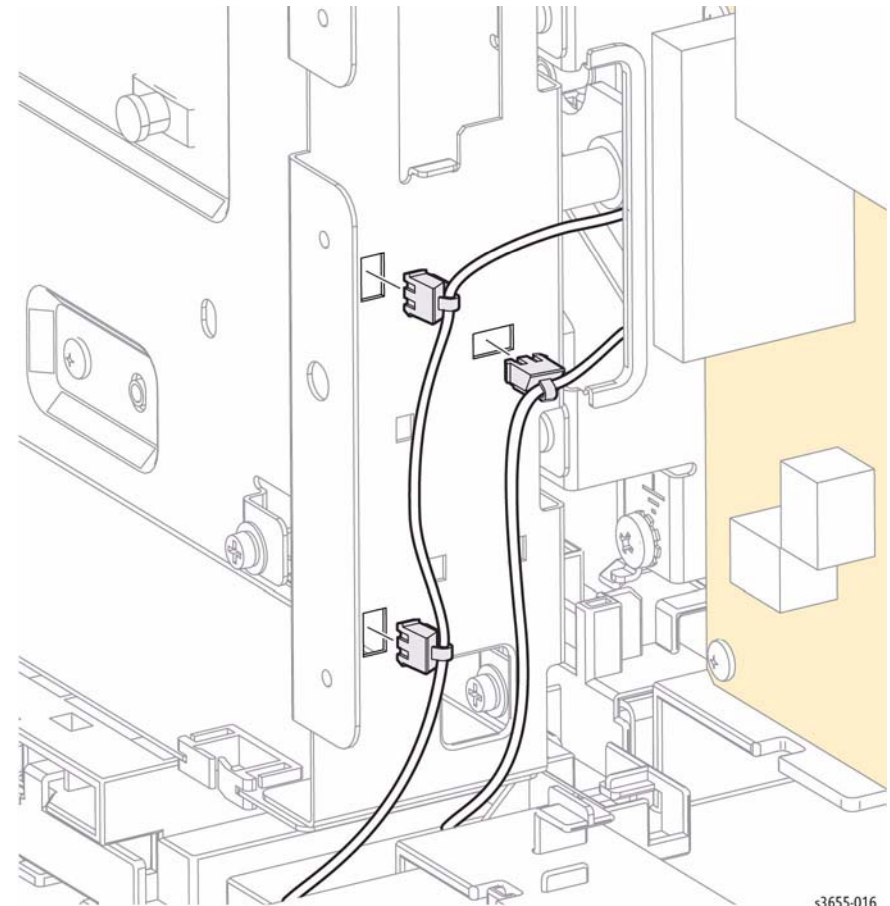

Figure 1 Release the harnesses from the ESS Housing

11. Refer to Figure 2 to remove 7 screws (silver, M3, 6mm) and 1 ground connection that secure the ESS housing to the chassis.

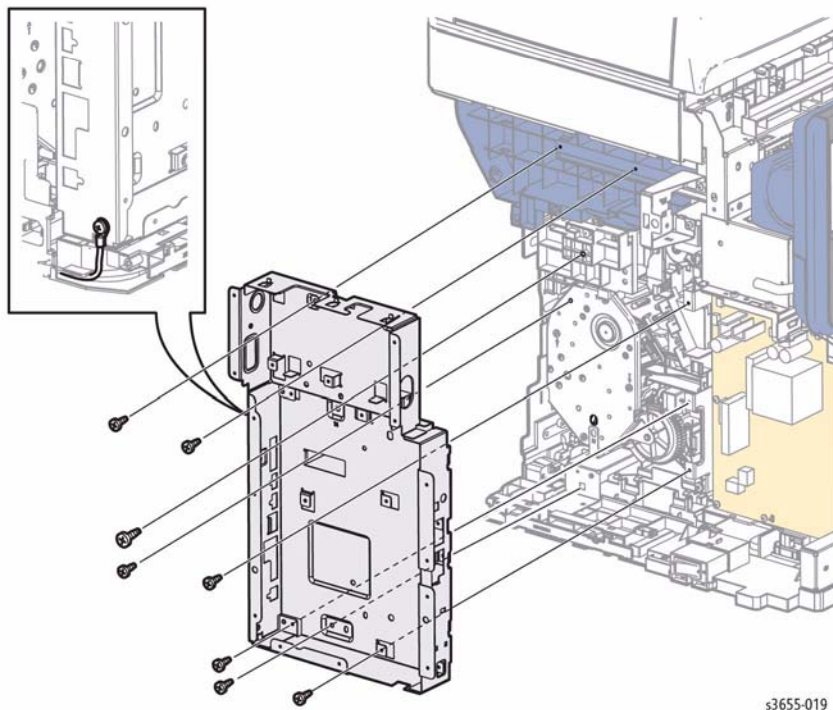

Figure 2 Remove the ESS Housing

REP 18.1.4 IIT Control Board

Parts List on PL 18.1 Item 4

Removal *Note: Before replacing the IIT Control board, see the critical information in Eureka Tip # 1368189.*

WARNING

Switch off the electricity to the machine. Disconnect the power cord from the customer supply while performing tasks that do not need electricity. Electricity can cause death or injury. Moving parts can cause injury.

CAUTION

Do not remove the IIT Control Board from the protective bag until ready for installation. Always wear a grounded wrist band while handling circuit boards.

CAUTION

Do not replace the MCU and IIT Control Board at the same time. Replace or check the IIIT Control Board first, then cycle system power before replacing the MCU Board.

1. If possible, print a Configuration page to capture current settings.
2. Ask the customer to export their address book. Customers can find instructions for exporting their address book in their User Guide or the Xerox.com Support page.
3. Open the Rear Cover.
4. Remove the Left Rear Cover, REP 19.2.2.
5. Open the Front Cover.
6. Remove the Left UI Base Cover, REP 1.1.6.
7. Remove the Left Side Cover, REP 19.2.1.
8. Remove the ESS housing cover, REP 18.1.1.
9. Refer to Figure 1 to locate and disconnect all IIT Control Board connections, and remove 6 screws (silver, M3, 6mm) to remove the IIT Control Board.
10. *Do not move the old ROM to the new IIT Control Board.*

Continued on next page

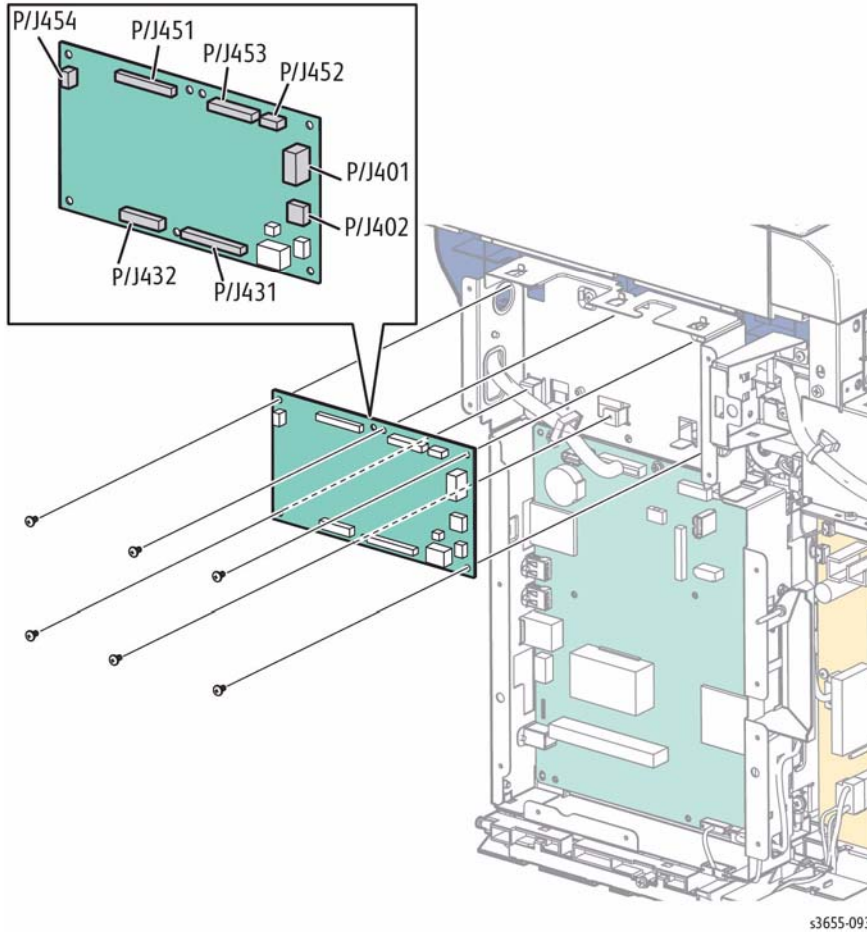
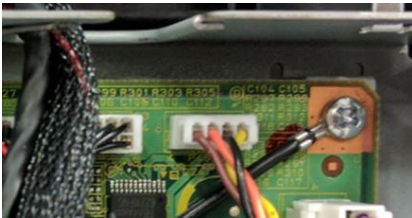

Figure 1 Remove the IIT Control Board

Replacement

1. Do not move the old ROM to the new IIT Control Board.
2. Perform DC945 IIT Calibration.
3. If wires pull out of P/J452, re-install brown, orange, black, yellow, as shown below.



REP 18.1.7 Fax Board

Parts List on PL 18.1 Item 7

Removal

WARNING

Switch off the electricity to the machine. Disconnect the power cord from the customer supply while performing tasks that do not need electricity. Electricity can cause death or injury. Moving parts can cause injury.

CAUTION

Do not remove the FAX Board from the protective bag until ready for installation. Always wear a grounded wrist band while handling circuit boards.

1. Open the Rear Cover.
2. Remove the Left Rear Cover, REP 19.2.2.
3. Open the Front Cover.
4. Remove the Left UI Base Cover, REP 1.1.6.
5. Remove the Left Side Cover, REP 19.2.1.
6. Refer to Figure 1 to locate and remove 2 screws (silver, M3, 6mm) that secure the FAX Board to the ESS housing cover and disconnect the FAX Cable from the ESS Board to remove the FAX Board.

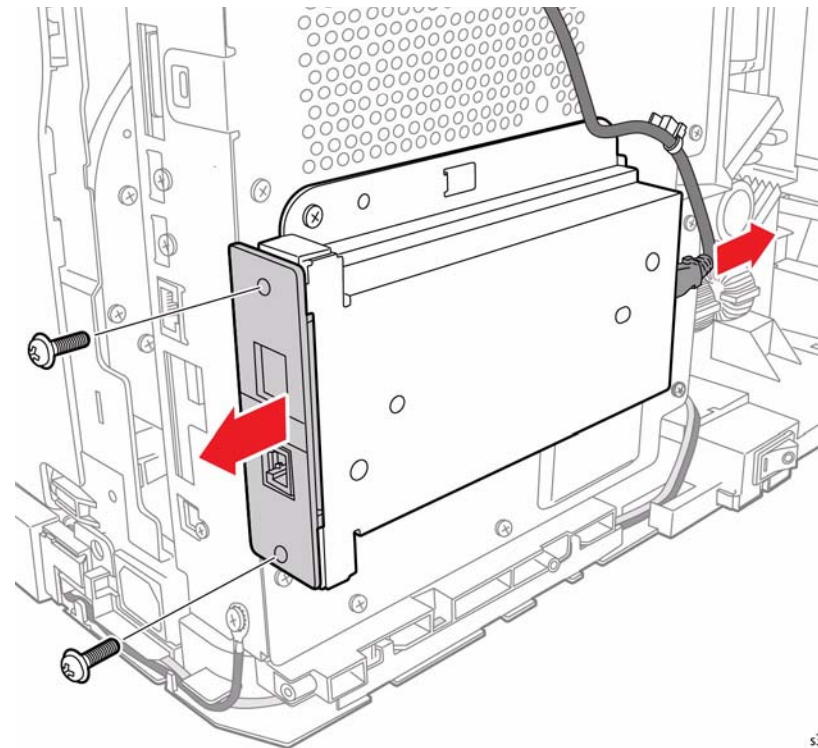

Figure 1 Remove the Fax Board

REP 18.1.10 Size Switch

Parts List on PL 18.1 Item 10

Removal

WARNING

Switch off the electricity to the machine. Disconnect the power cord from the customer supply while performing tasks that do not need electricity. Electricity can cause death or injury. Moving parts can cause injury.

1. Open the Rear Cover.
2. Remove the Left Rear Cover, REP 19.2.2.
3. Open the Front Cover.
4. Remove the Left UI Base Cover, REP 1.1.6.
5. Remove the Left Side Cover, REP 19.2.1.
6. Remove the LVPS, REP 18.1.12.
7. Refer to Figure 1 to locate and release 3 hooks that secure the switch cover and remove.
8. Disconnect the Option Feeder and Size Switch P/J131 connections.
9. Remove 1 screw (silver, tapping, M3, 8mm) to remove the switch.

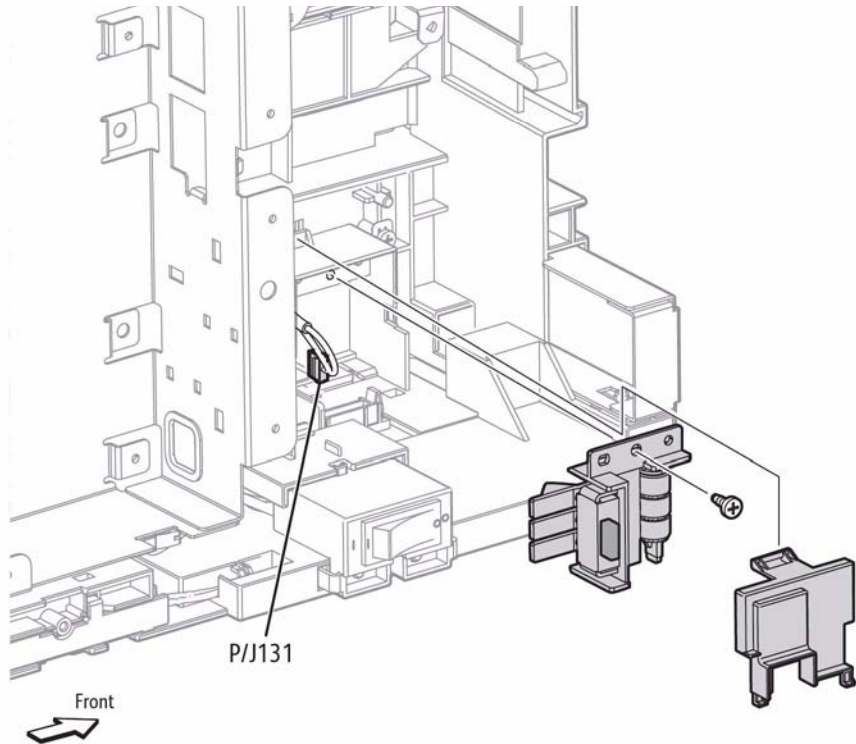

Figure 1 Remove the Size Switch

REP 18.1.12 LVPS

Parts List on PL 18.1 Item 12

Removal

WARNING

Switch off the electricity to the machine. Disconnect the power cord from the customer supply while performing tasks that do not need electricity. Electricity can cause death or injury. Moving parts can cause injury.

CAUTION

Do not remove the LVPS from the protective bag until ready for installation. Always wear a grounded wrist band while handling circuit boards.

1. Open the Rear Cover.
2. Remove the Left Rear Cover, REP 19.2.2.
3. Open the Front Cover.
4. Remove the Left UI Base Cover, REP 1.1.6.
5. Remove the Left Side Cover, REP 19.2.1.
6. Refer to Figure 1 to locate and disconnect all connections and remove 8 screws (silver, M3, 6mm) to remove the LVPS.

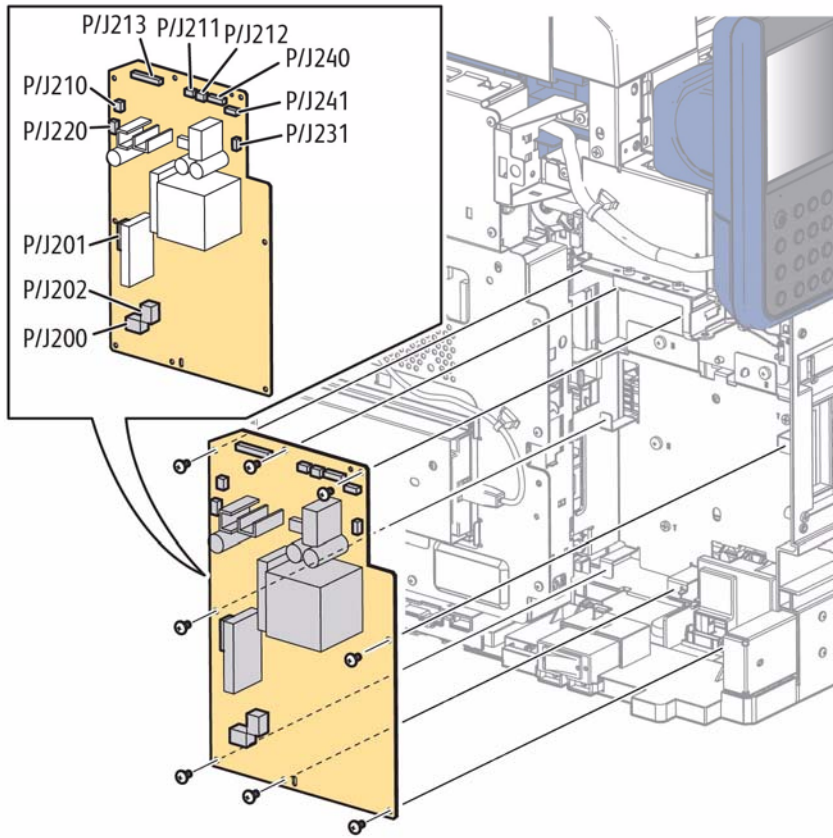

Figure 1 Remove the LVPS

s3655-049

REP 18.1.14 Side USB Assembly

Parts List on PL 18.1 Item 14

Removal

WARNING

Switch off the electricity to the machine. Disconnect the power cord from the customer supply while performing tasks that do not need electricity. Electricity can cause death or injury. Moving parts can cause injury.

1. Open the Rear Cover.
2. Remove the Left Rear Cover, REP 19.2.2.
3. Open the Front Cover.
4. Remove the Left UI Base Cover, REP 1.1.6.
5. Remove the Left Side Cover, REP 19.2.1.
6. Disconnect the Side USB Assembly from the ESS Board and release the harness from the ESS housing cover.
7. Refer to Figure 1 to locate and remove 2 screws (silver, M3, 6mm) that secure the bracket to the chassis.

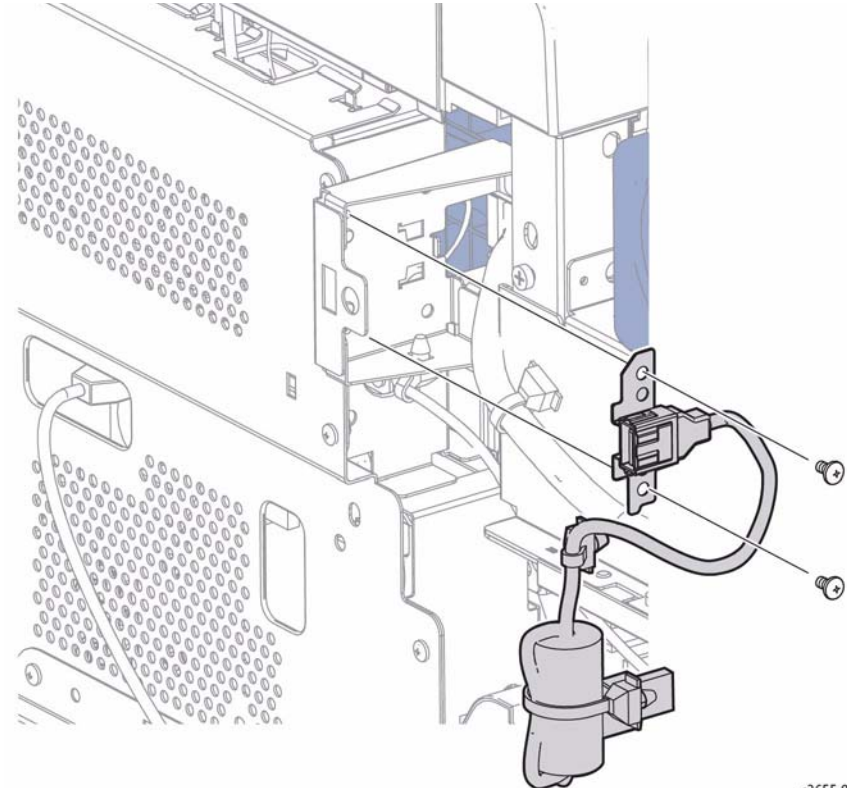

Figure 1 Remove the Side USB Assembly

s3655-095

REP 18.1.16 Front Interlock Switch Assembly

Parts List on PL 18.1 Item 16

Removal

WARNING

Switch off the electricity to the machine. Disconnect the power cord from the customer supply while performing tasks that do not need electricity. Electricity can cause death or injury. Moving parts can cause injury.

1. Open the Rear Cover.
2. Remove the Left Rear Cover, REP 19.2.2.
3. Open the Front Cover.
4. Remove the Left UI Base Cover, REP 1.1.6.
5. Remove the Left Side Cover, REP 19.2.1.
6. Refer to Figure 1 to locate and disconnect the Front Interlock Switch from the LVPS and remove 2 screws (silver, tapping, 8mm) that secure the bracket to the chassis.

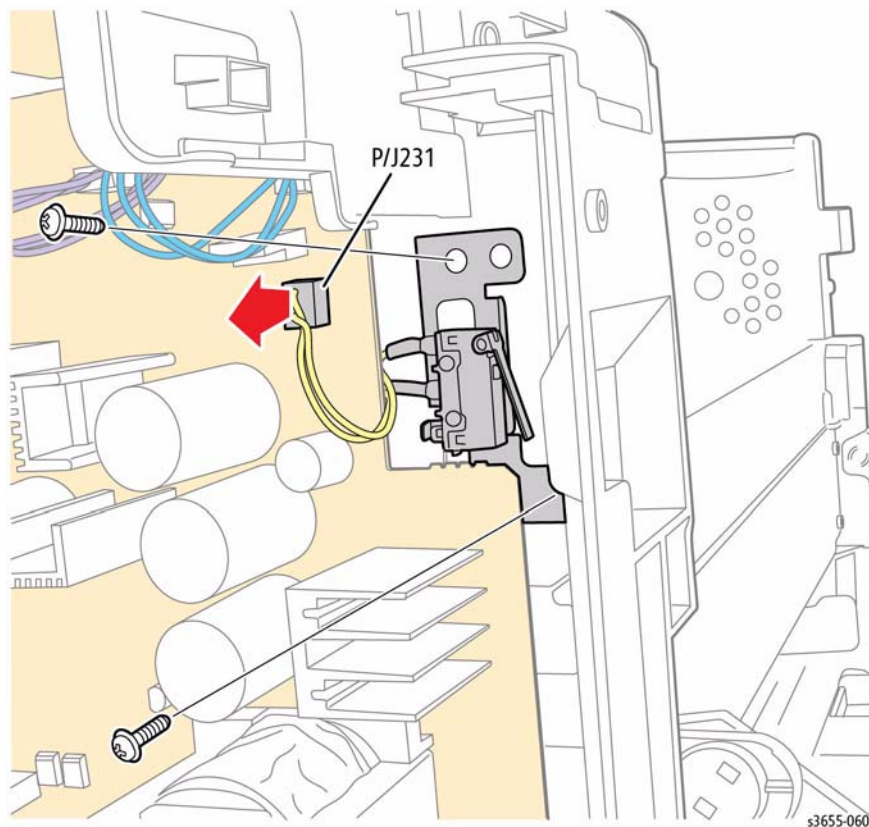

Figure 1 Remove the Front Interlock Switch

REP 18.1.17 RAM

Parts List on PL 18.1 Item 17

Removal

WARNING

Switch off the electricity to the machine. Disconnect the power cord from the customer supply while performing tasks that do not need electricity. Electricity can cause death or injury. Moving parts can cause injury.

CAUTION

Do not remove the RAM from the protective bag until ready for installation. Always wear a grounded wrist band while handling circuit boards.

1. Open the Rear Cover.
2. Remove the Left Rear Cover, REP 19.2.2.
3. Open the Front Cover.
4. Remove the Left UI Base Cover, REP 1.1.6.
5. Remove the Left Side Cover, REP 19.2.1.
6. Remove the ESS housing cover (REP 18.1.1).
7. Refer to Figure 1 to locate and release 2 clamps that secure the RAM to the socket on the ESS Board, then gently remove the RAM.

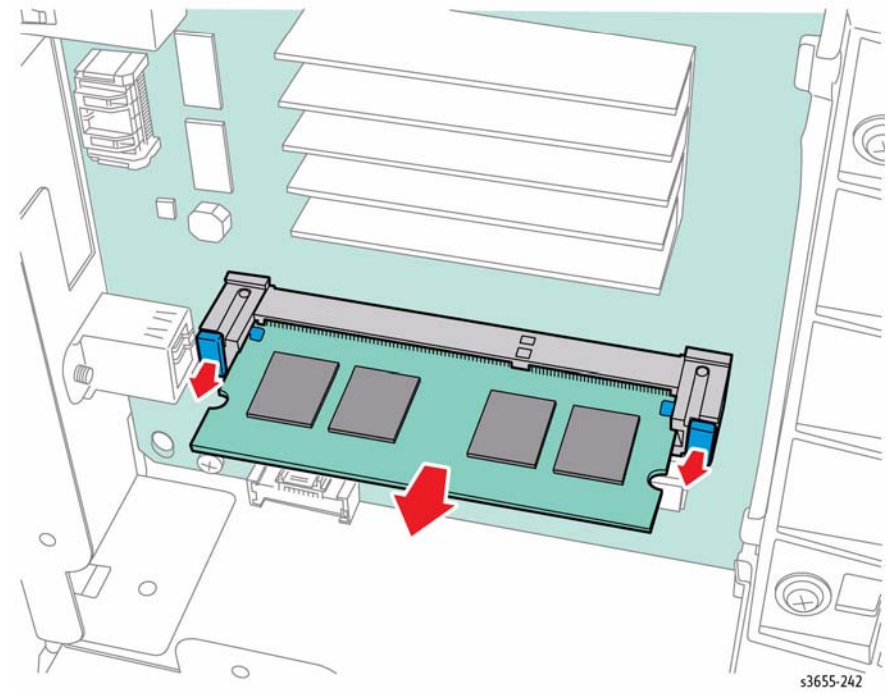

Figure 1 Remove the RAM

REP 18.1.96 SD Card

Parts List on PL 18.1 Item 96

Removal

WARNING

Switch off the electricity to the machine. Disconnect the power cord from the customer supply while performing tasks that do not need electricity. Electricity can cause death or injury. Moving parts can cause injury.

CAUTION

Do not remove the SD Card from the protective bag until ready for installation. Always wear a grounded wrist band while handling circuit boards.

NOTE: SD Cards contain data specific to a particular geographic region.

Refer to Figure 1 to locate and press to eject the SD Card from its rear panel slot.

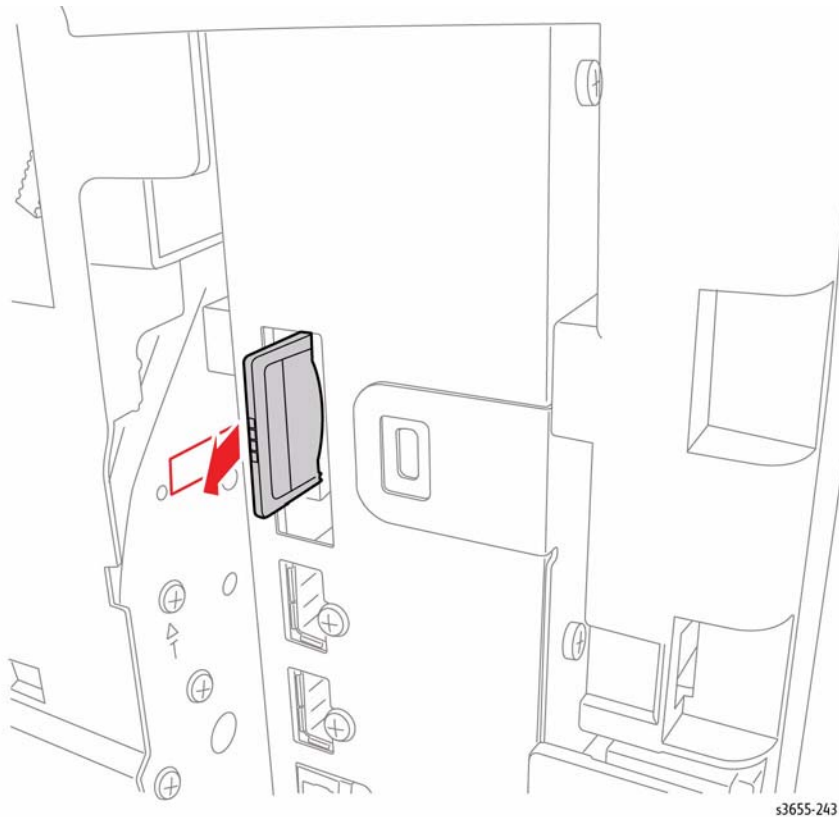

Figure 1 Remove the SD Card

REP 18.1.97 Hard Drive

Parts List on PL 18.1 Item 97

Removal

WARNING

Switch off the electricity to the machine. Disconnect the power cord from the customer supply while performing tasks that do not need electricity. Electricity can cause death or injury. Moving parts can cause injury.

CAUTION

Do not remove the Hard Drive from the protective bag until ready for installation. Always wear a grounded wrist band while handling circuit boards.

1. Open Front Cover.
2. Remove Left UI Base Cover, REP 1.1.6
3. Open Rear Cover.
4. Remove Left Rear Cover, REP 19.2.2.
5. Remove Left Side Cover, REP 19.2.1.
6. Remove ESS housing cover, REP 18.1.1.
7. Disconnect the Hard Drive from the ESS Board.
8. Refer to Figure 1 to locate and to remove 2 screws (silver, with a washer, M3, 6mm) that secure the Hard Drive bracket to the ESS Board and ESS housing to remove.

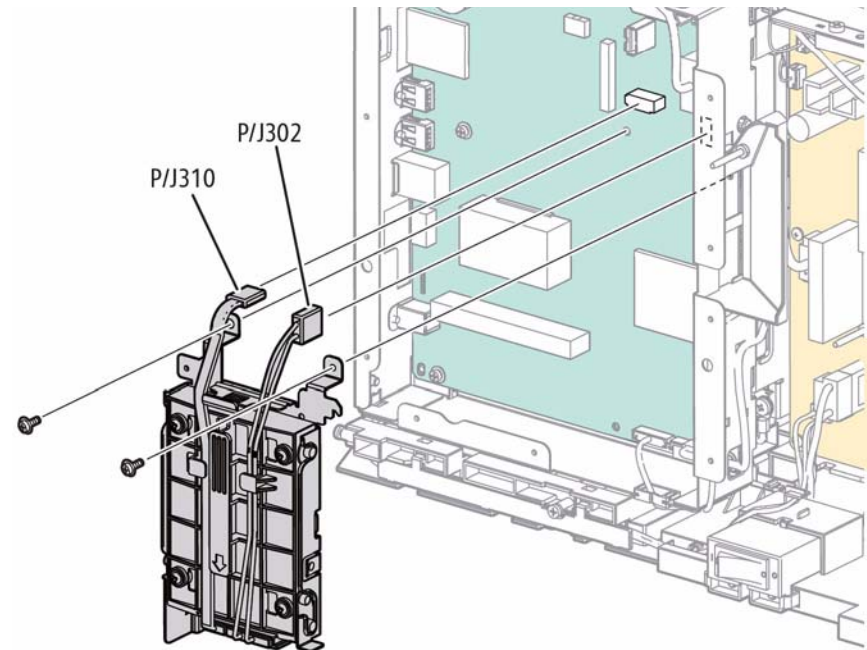

Figure 1 Remove the Hard Drive

After installing the HDD, perform [GP 9 Altboot](#).

REP 18.1.98 ESS Board

Parts List on PL 18.1 Item 3

Removal

WARNING

Switch off the electricity to the machine. Disconnect the power cord from the customer supply while performing tasks that do not need electricity. Electricity can cause death or injury. Moving parts can cause injury.

CAUTION

Do not replace the MCU and ESS Boards at the same time. Replace or check the ESS Board first, then cycle system power before replacing the MCU Board.

CAUTION

Do not remove the ESS Board from the protective bag until ready for installation. Always wear a grounded wrist band while handling circuit boards.

1. If possible, print a Configuration page to capture current settings.
2. Ask the customer to export their address book. Customers can find instructions for exporting their address book in their User Guide or on the Xerox.com Support page.
3. Open the Rear Cover.
4. Remove the Left Rear Cover, REP 19.2.2.
5. Open the Front Cover.
6. Remove the Left UI Base Cover, REP 1.1.6.
7. Remove the Left Side Cover, REP 19.2.1.
8. Remove the ESS housing cover, REP 18.1.1.
9. Remove the Hard Drive, REP 18.1.97.
10. Refer to Figure 1 and disconnect all connections to the ESS Board, then remove 5 screws (silver, with a washer, M3, 6mm), 3 screws (silver, M4, A6mm) that secure the ESS Board to the ESS housing.

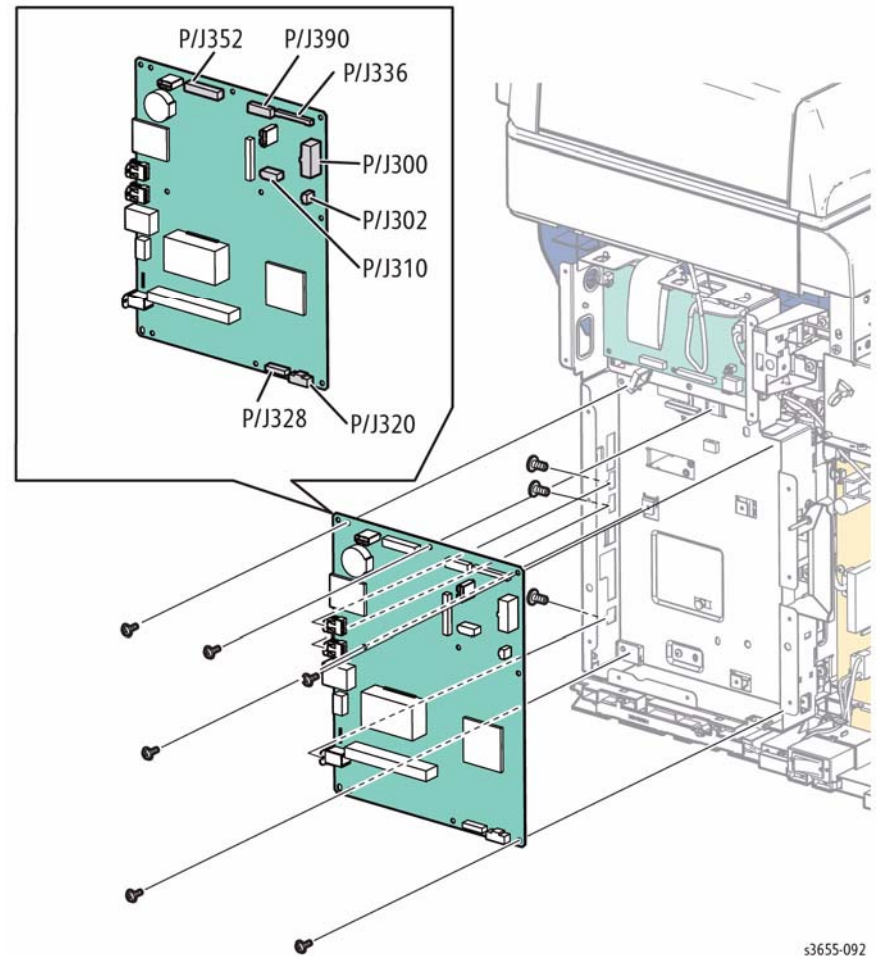

Figure 1 Remove the ESS Board

Replacement

1. Refer to Figure 2 to locate and move the SD Card, ROM and RAM to the replacement board.
Caution: The legs of the ROM are extremely fragile, and the ROM is not spared! Use a small, flat-blade screwdriver to carefully pry each side of the ROM up.
2. Ask the customer to restore their configuration settings.

REP 18.2.2 MCU Board

Parts List on PL 18.2 Item 2

Removal

WARNING

Switch off the electricity to the machine. Disconnect the power cord from the customer supply while performing tasks that do not need electricity. Electricity can cause death or injury. Moving parts can cause injury.

CAUTION

Do not replace the MCU and ESS Boards at the same time. Replace or check the ESS Board first, then cycle system power before replacing the MCU Board.

CAUTION

Do not remove the MCU Board from the protective bag until ready for installation. Always wear a grounded wrist band while handling circuit boards.

CAUTION

Cover the Drum Cartridge after removal to prevent light exposure.

NOTE: If possible, before replacing the MCU Board, save NVM to the ESS Board (Save NVM to ESS) before removal to save configuration data.

1. Open the Front Cover.
2. Remove the Drum Cartridge, REP 8.1.1.
3. Refer to Figure 1 to locate and release 3 hooks that secure the MCU cover and disconnect all MCU Board connections, then remove 4 screws (silver, M3, 6mm) to remove the MCU Board.

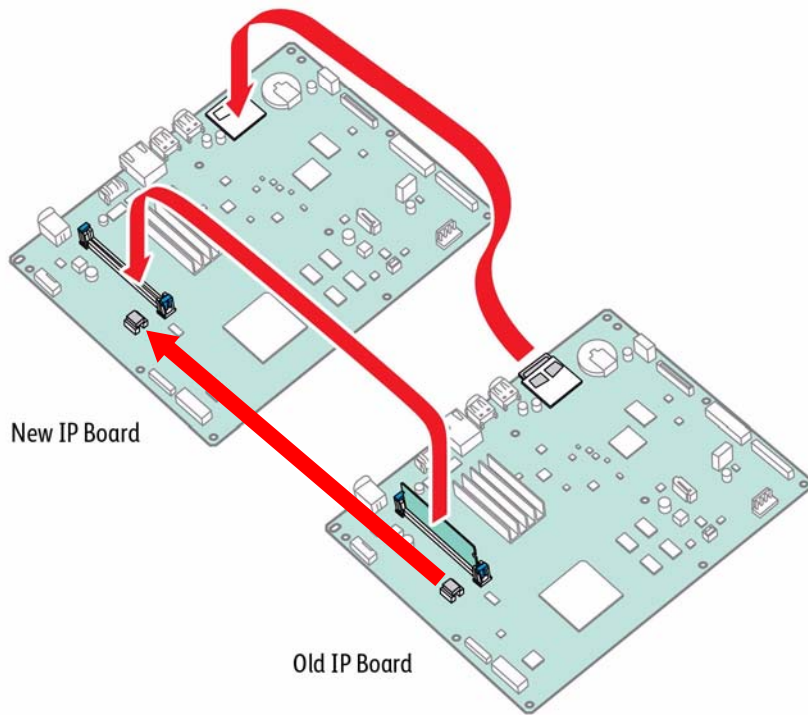

s3655-245

Figure 2 Transfer components to the replacement board

2. Ask the customer restore their configuration settings.

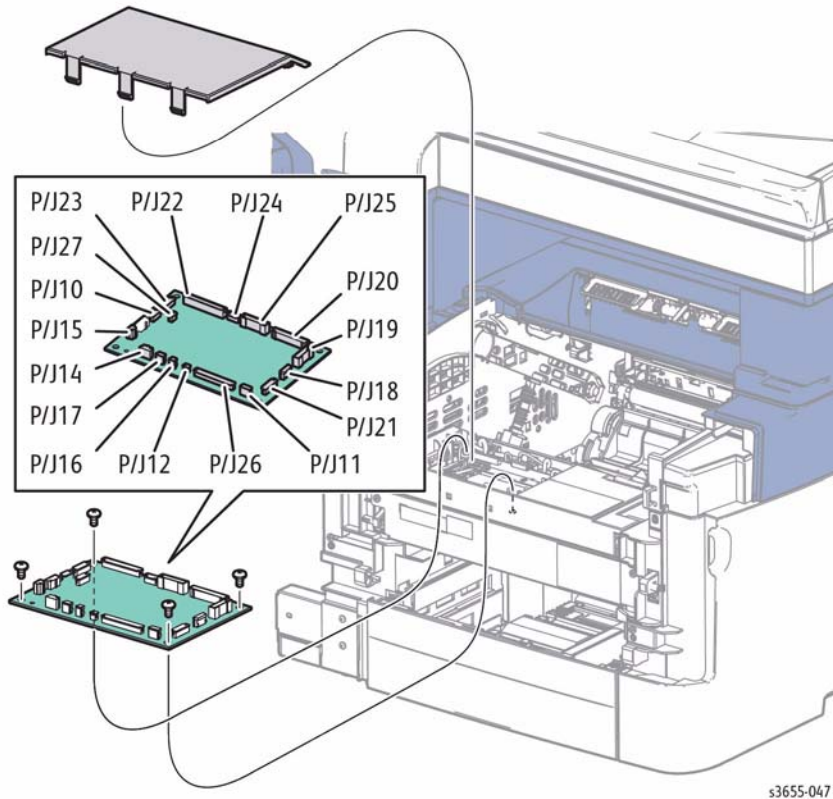

Figure 1 Remove the MCU Board

s3655-047

Replacement

P15 is Black. P12 is White. Install a new MCU Board and use Load NVM from ESS to restore configuration data from the ESS Board.

REP 18.2.5 HVPS

Parts List on PL 18.2 Item 5

Removal

WARNING

Switch off the electricity to the machine. Disconnect the power cord from the customer supply while performing tasks that do not need electricity. Electricity can cause death or injury. Moving parts can cause injury.

WARNING

Do not touch the Fuser while it is hot.

CAUTION

Do not remove the HVPS from the protective bag until ready for installation. Always wear a grounded wrist band while handling circuit boards.

1. Open the Front Cover.
2. Open the Rear Cover.
3. Remove the Stapler Cover, REP 19.1.11 or Outer Right Cover, REP 19.1.13.
4. Remove the Right Side Cover, REP 19.1.10.
5. Refer to Figure 1 to disconnect the HVPS, locate and remove 7 screws (silver, tapping, 8mm), and release 2 bosses to remove.

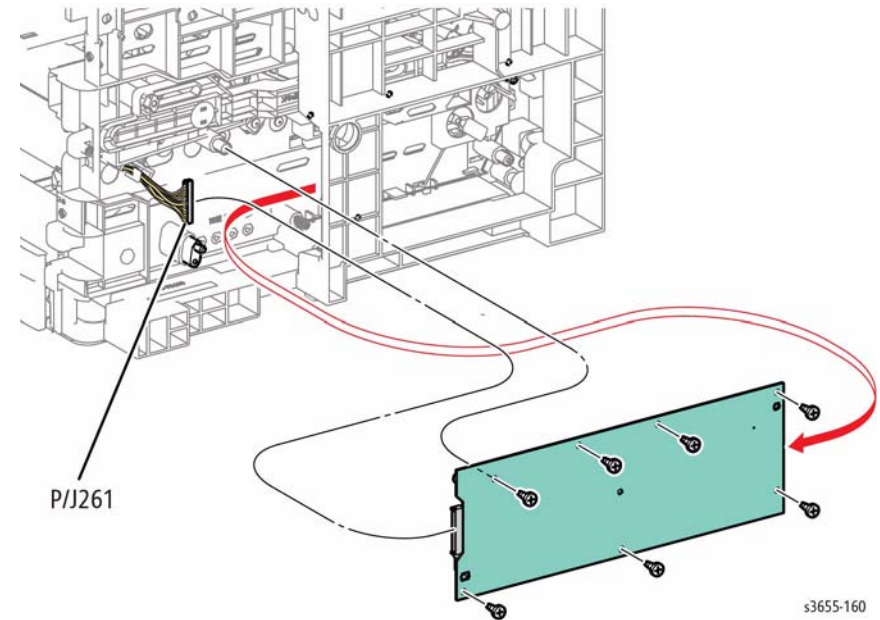

Figure 1 Remove the HVPS

s3655-160

Replacement

Refer to Figure 2 to check the Registration Sensor Shutters are properly positioned, the HVPS is connected, the 3 conductive springs on the chassis contact the HVPS terminals, and the HVPS is seated on the bosses.

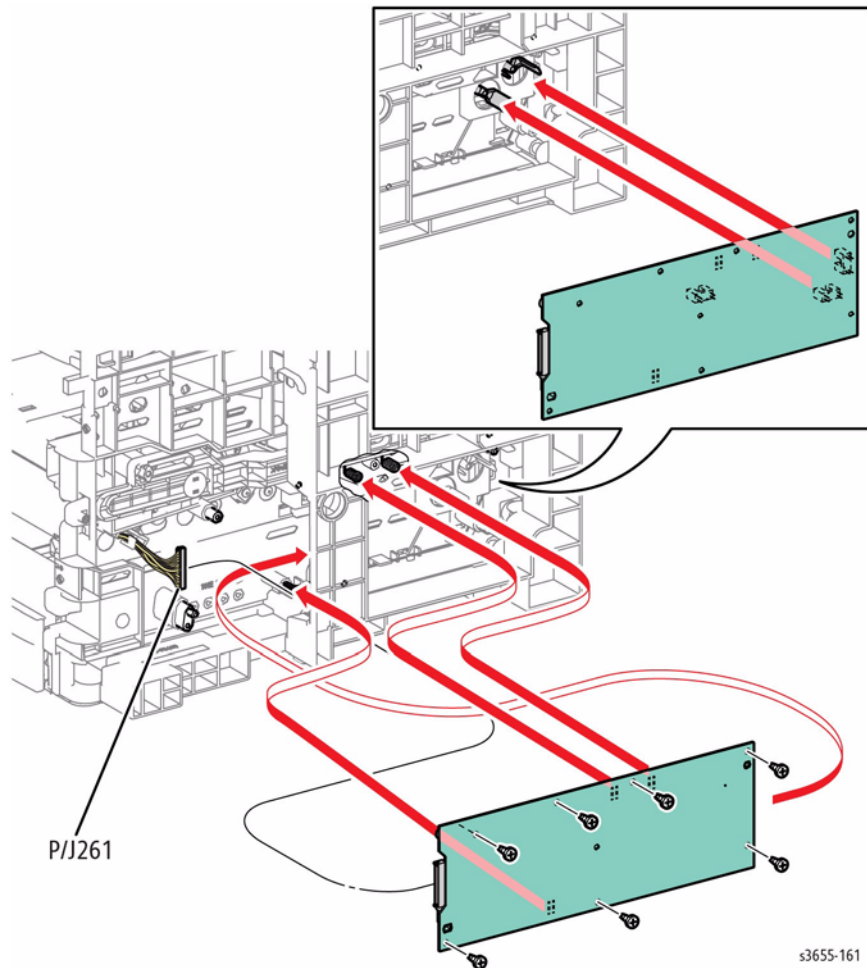

Figure 2 Install the HVPS

REP 18.2.6 Stapler Assembly

Parts List on PL 18.2 Item 6

Removal

WARNING

Switch off the electricity to the machine. Disconnect the power cord from the customer supply while performing tasks that do not need electricity. Electricity can cause death or injury. Moving parts can cause injury.

1. Open the Front Cover.
2. Open the Rear Cover.
3. Remove the Stapler Cover, REP 19.1.11 or Outer Right Cover, REP 19.1.13.
4. Remove the Right Side Cover, REP 19.1.10.
5. Disconnect the Stapler from the Stapler LVPS.
6. Refer to Figure 1 to locate and remove 2 screws (silver, tapping, M3, 8mm) that secure the Stapler housing.

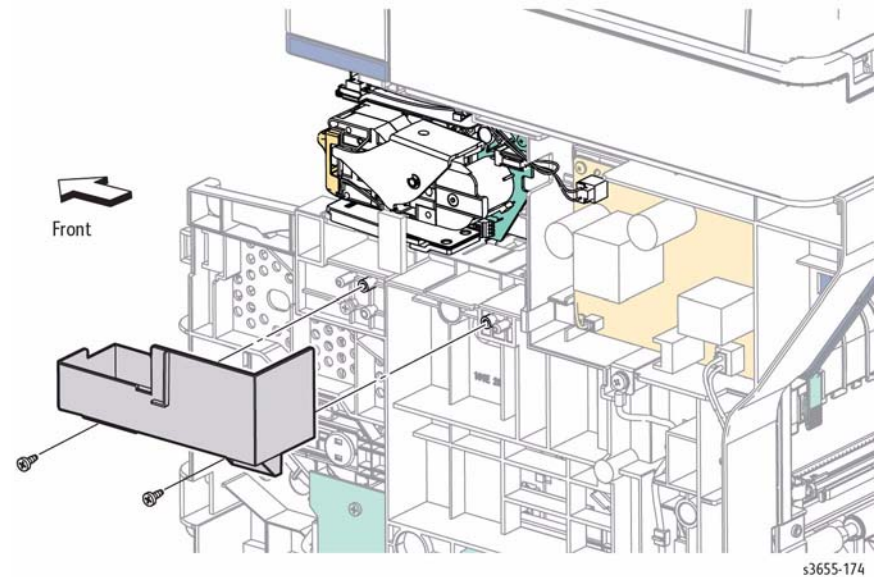

Figure 1 Remove the Stapler Housing

7. Refer to Figure 2 to locate and remove 3 screws (silver, tapping, M3, 8mm) that secure the Stapler Assembly to the chassis.

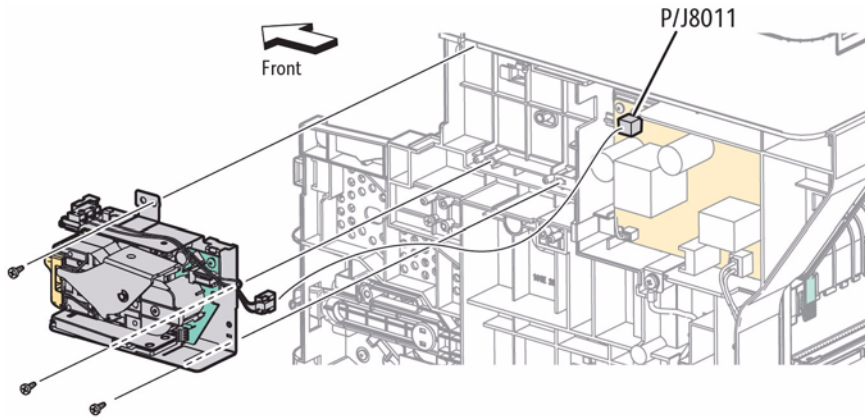

Figure 2 Remove the Stapler Assembly

REP 18.2.9 Stapler LVPS

Parts List on PL 18.2 Item 9

Removal

WARNING

Switch off the electricity to the machine. Disconnect the power cord from the customer supply while performing tasks that do not need electricity. Electricity can cause death or injury. Moving parts can cause injury.

CAUTION

Do not remove the Stapler LVPS from the protective bag until ready for installation. Always wear a grounded wrist band while handling circuit boards.

1. Open the Front Cover.
2. Open the Rear Cover.
3. Remove the Stapler Cover, REP 19.1.11 or Outer Right Cover, REP 19.1.13.
4. Remove the Right Side Cover, REP 19.1.10.
5. Disconnect all connections to the Stapler LVPS.
6. Refer to Figure 1 to locate and remove 4 screws (silver, M3, 6mm) to remove the board.

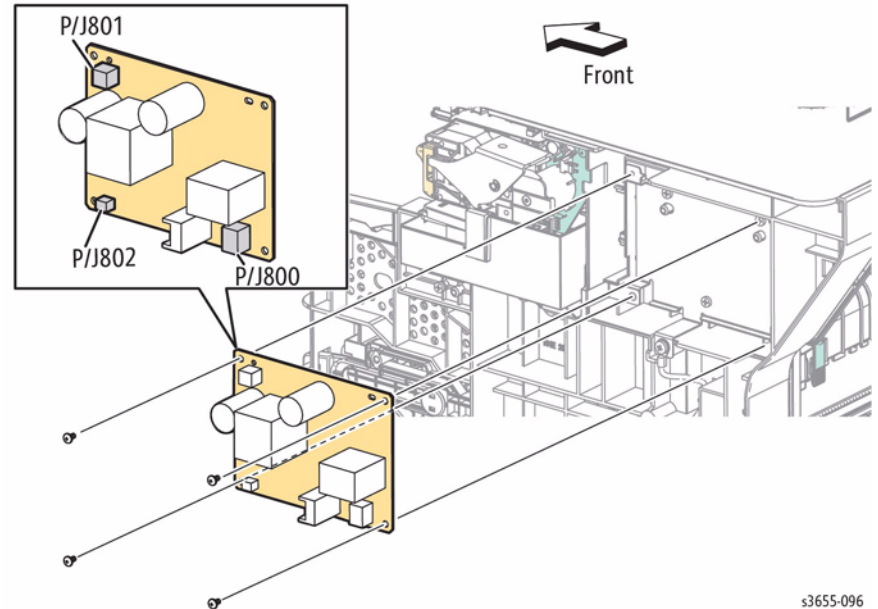

Figure 1 Remove the Stapler LVPS

REP 18.4.99 AC Inlet Harness

Parts List on PL 18.4 Item 99

Removal

WARNING

Switch off the electricity to the machine. Disconnect the power cord from the customer supply while performing tasks that do not need electricity. Electricity can cause death or injury. Moving parts can cause injury.

1. Open the Rear Cover.
2. Remove the Left Rear Cover, REP 19.2.2.
3. Open the Front Cover.
4. Remove the Left UI Base Cover, REP 1.1.6.
5. Remove the Left Side Cover, REP 19.2.1.
6. Remove the ESS housing cover, REP 18.1.1.
7. Remove the ESS housing, REP 18.1.2.
8. Remove 2 screws (silver, tapping, 8mm and silver, M6, 6mm) that secure the Main Drive Assembly support bracket and remove the bracket.
9. Refer to Figure 1 to locate and disconnect the AC Inlet Harness from the LVPS and release 2 clips that secure the power switch to the chassis, then release the harness from the harness guide.
10. Remove 1 screw (silver, M6 with lock washer) that secures the AC ground wire and release the ground wire from the harness guide.
11. Release the hook that secures the AC socket and slide the socket to the rear to remove.

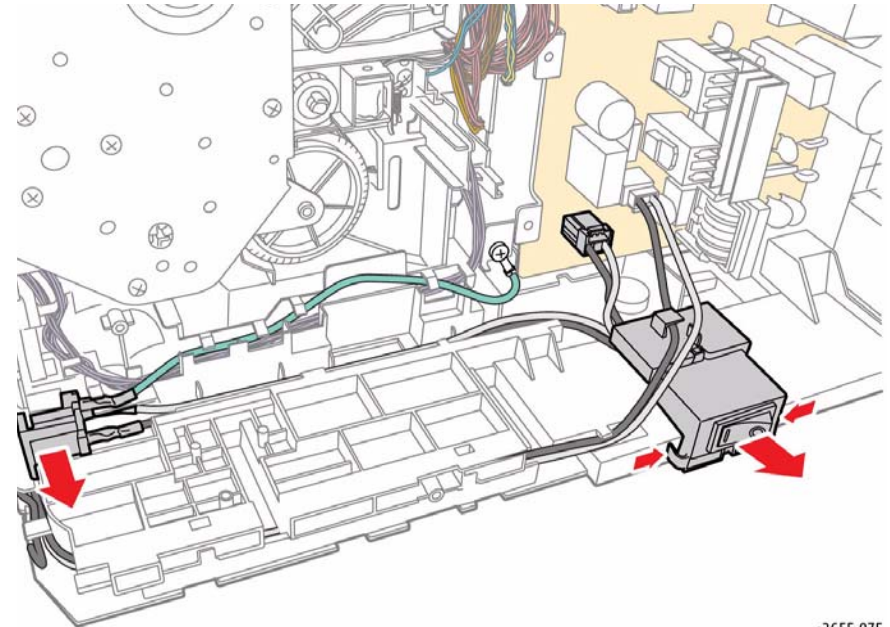

s3655-075

Figure 1 Remove the AC Inlet Harness

REP 19.1.10 Right Side Cover

Parts List on PL 19.1 Item 10

Removal

WARNING

Switch off the electricity to the machine. Disconnect the power cord from the customer supply while performing tasks that do not need electricity. Electricity can cause death or injury. Moving parts can cause injury.

WARNING

Do not touch the Fuser while it is hot.

1. Open the Front Cover.
2. Remove the Stapler Cover, REP 19.1.11 or Outer Right Cover, REP 19.1.13.
3. Open the Rear Cover.
4. Refer to Figure 1 to locate and remove 2 screws (silver, tapping, M3, 8mm), release 4 bosses, and 2 hooks to remove the cover.

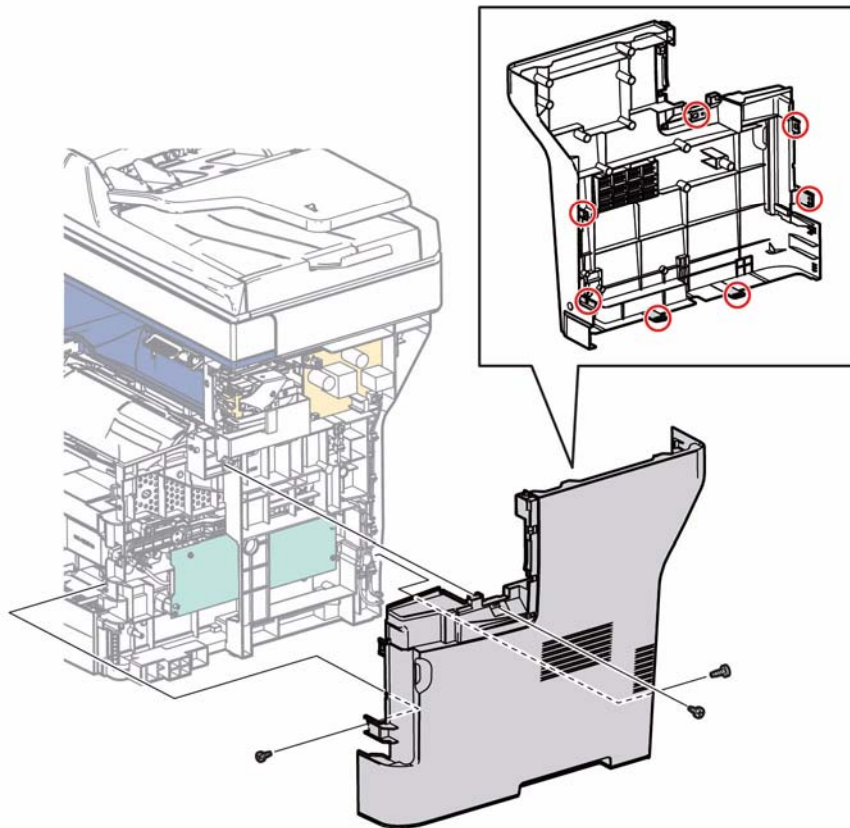

Figure 1 Remove the Right Side Cover

3655-104

REP 19.1.11 Stapler Cover

Parts List on PL 19.1 Item 11

Removal

WARNING

Switch off the electricity to the machine. Disconnect the power cord from the customer supply while performing tasks that do not need electricity. Electricity can cause death or injury. Moving parts can cause injury.

1. Open the Front Cover.
2. Open the Stapler Cartridge Cover.
3. Refer to Figure 1 to locate and remove 2 screws (silver, tapping, M3, 8mm) to remove the cover.

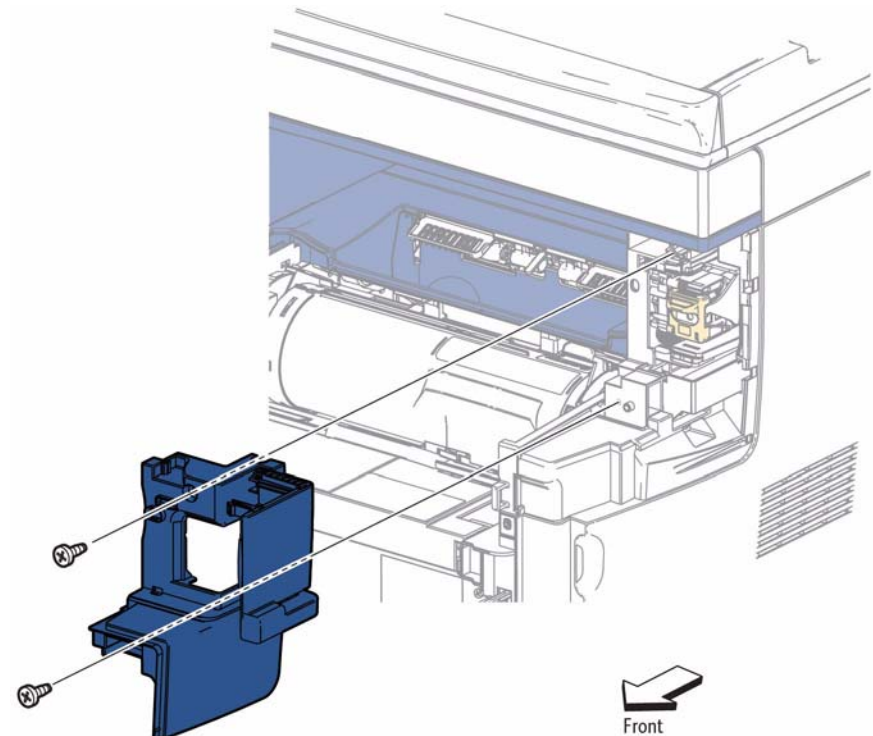

Figure 1 Remove the Stapler Cover Assembly

s3655-104

REP 19.1.12 Stapler Cartridge Cover

Parts List on PL 19.1 Item 12

Removal

WARNING

Switch off the electricity to the machine. Disconnect the power cord from the customer supply while performing tasks that do not need electricity. Electricity can cause death or injury. Moving parts can cause injury.

1. Open the Front Cover.
2. Remove the Stapler Cover, REP 19.1.11.
3. Refer to Figure 1 and lift the cover from the bosses on the Stapler Cover to remove the cover.

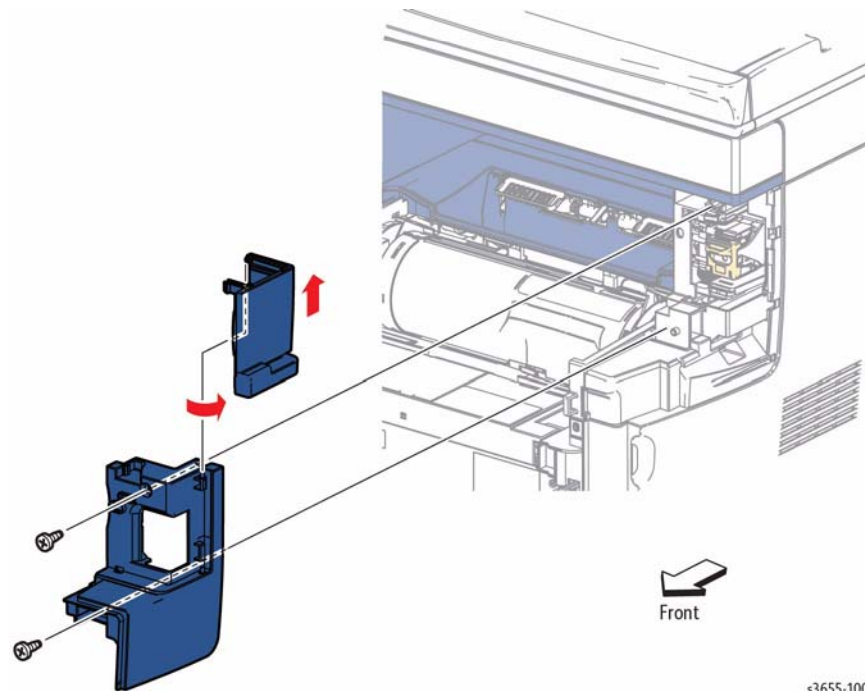

Figure 1 Remove the Stapler Cartridge Cover

REP 19.1.13 Outer Right Cover

Parts List on PL 19.1 Item 13

Removal

WARNING

Switch off the electricity to the machine. Disconnect the power cord from the customer supply while performing tasks that do not need electricity. Electricity can cause death or injury. Moving parts can cause injury.

Procedure for printers not equipped with stapler option.

1. Open the Front Cover.
2. Refer to Figure 1 to locate and remove 1 screw (silver, tapping, 8mm) and release 1 hook at the top to remove the Outer Right Cover.

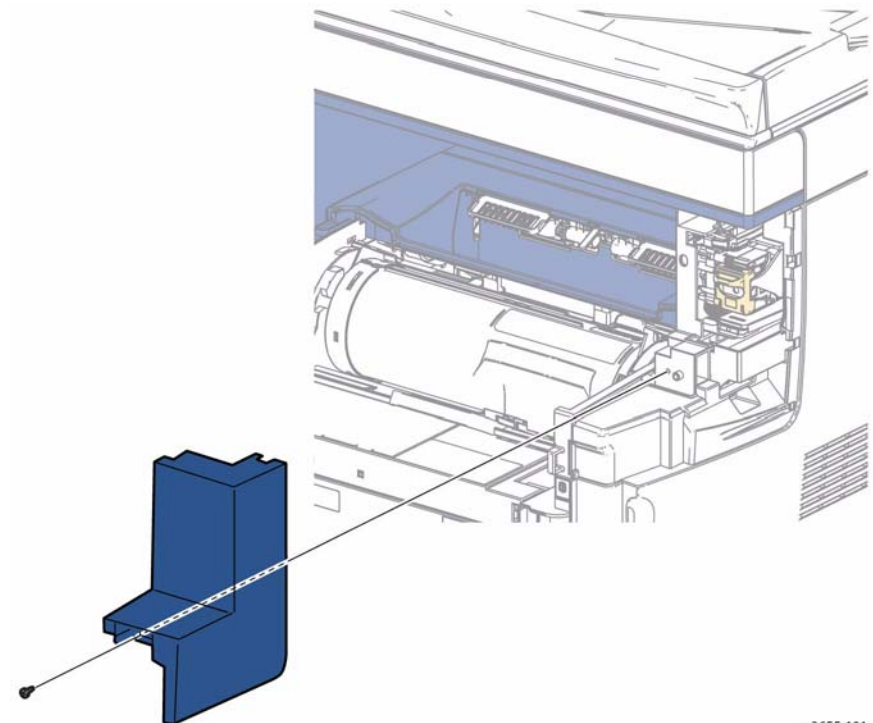

Figure 1 Remove Outer Right Cover

REP 19.1.14 Inner Right Cover

Parts List on PL 19.1 Item 14

Removal

WARNING

Switch off the electricity to the machine. Disconnect the power cord from the customer supply while performing tasks that do not need electricity. Electricity can cause death or injury. Moving parts can cause injury.

WARNING

Do not touch the Fuser while it is hot.

1. Open the Rear Cover.
2. Open the Front Cover.
3. Remove the Drum Cartridge, REP 8.1.1.
4. Remove the Stapler Cover, REP 19.1.11 or Outer Right Cover, REP 19.1.13.
5. Remove the Right Side Cover, REP 19.1.10.
6. Refer to Figure 1 to locate and release 1 hook and slide the cover to the back to remove.

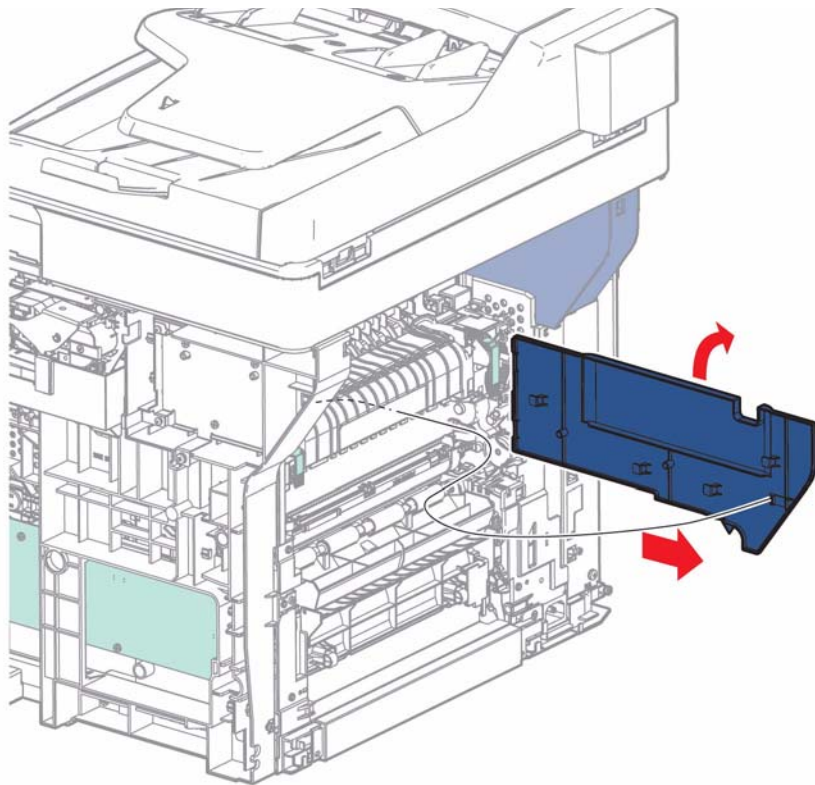

s3655-113

Figure 1 Remove Inner Right Side Cover

REP 19.1.96 Front Cover Assembly

Parts List on PL 19.1 Item 96

Removal

WARNING

Switch off the electricity to the machine. Disconnect the power cord from the customer supply while performing tasks that do not need electricity. Electricity can cause death or injury. Moving parts can cause injury.

1. Remove the Bypass Tray, REP 13.2.9.
2. Open the Front Cover.
3. Refer to Figure 1 to locate and release 2 hooks that secure the cover to the Left and Right Front Links, then release the cover from the hinge boss at each side.

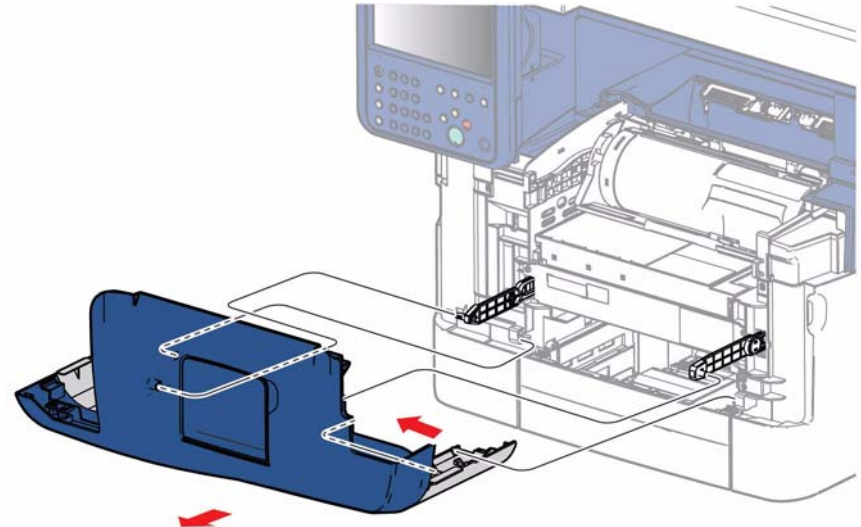

s3655-098

Figure 1 Remove the Front Cover Assembly

4. Refer to Figure 2 to locate and remove 2 screws (silver, tapping, M3, 8mm) and release 3 bosses that secure the Top Cover Assembly to the Front Cover Assembly.

REP 19.1.97 Top Cover Assembly

Parts List on PL 19.1 Item 97

Removal

WARNING

Switch off the electricity to the machine. Disconnect the power cord from the customer supply while performing tasks that do not need electricity. Electricity can cause death or injury. Moving parts can cause injury.

WARNING

Do not touch the Fuser while it is hot.

1. Remove the Bypass Tray, REP 13.2.9.
2. Remove the Output Tray Extension, REP 19.1.99
3. Open the Front Cover.
4. Refer to Figure 1 to locate and release 2 hooks that secure the cover to the Left and Right Front Links, then release the cover from the hinge boss at each side.

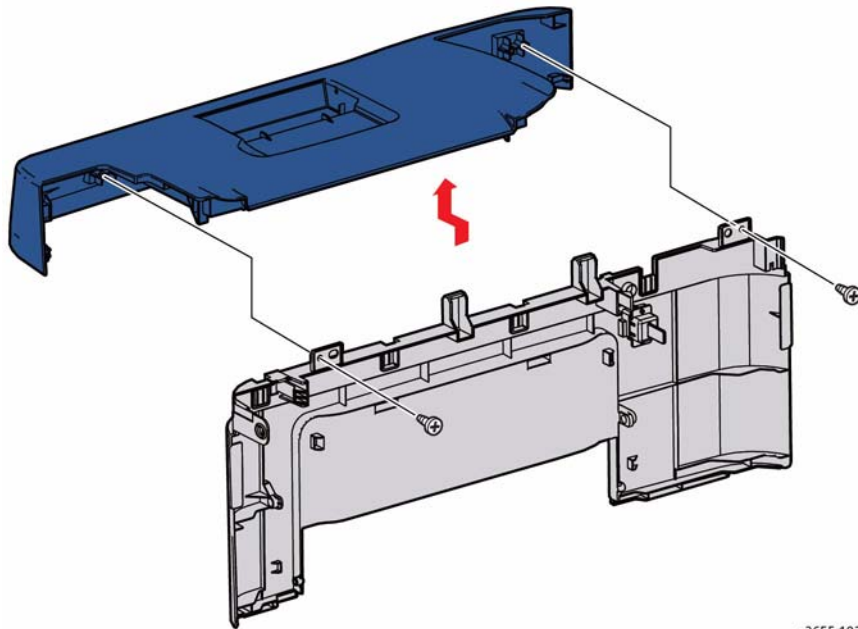

Figure 2 Separate the Front Cover Assembly

s3655-102

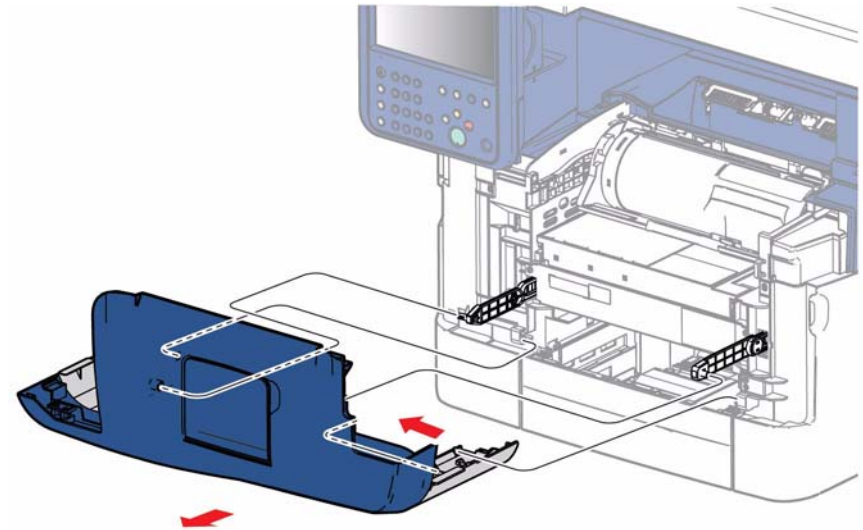

Figure 1 Remove the Front Cover Assembly

s3655-098

5. Refer to Figure 2 to locate and remove 2 screws (silver, tapping, M3, 8mm) and release 3 bosses that secure the Top Cover to the Front Cover.

REP 19.1.98 Stapler Cover Assembly

Parts List on PL 19.1 Item 98

Removal

WARNING

Switch off the electricity to the machine. Disconnect the power cord from the customer supply while performing tasks that do not need electricity. Electricity can cause death or injury. Moving parts can cause injury.

1. Open the Front Cover.
2. Refer to Figure 1 to locate and remove 2 screws (silver, tapping, 8mm) that secure the Stapler Cover Assembly to the chassis.

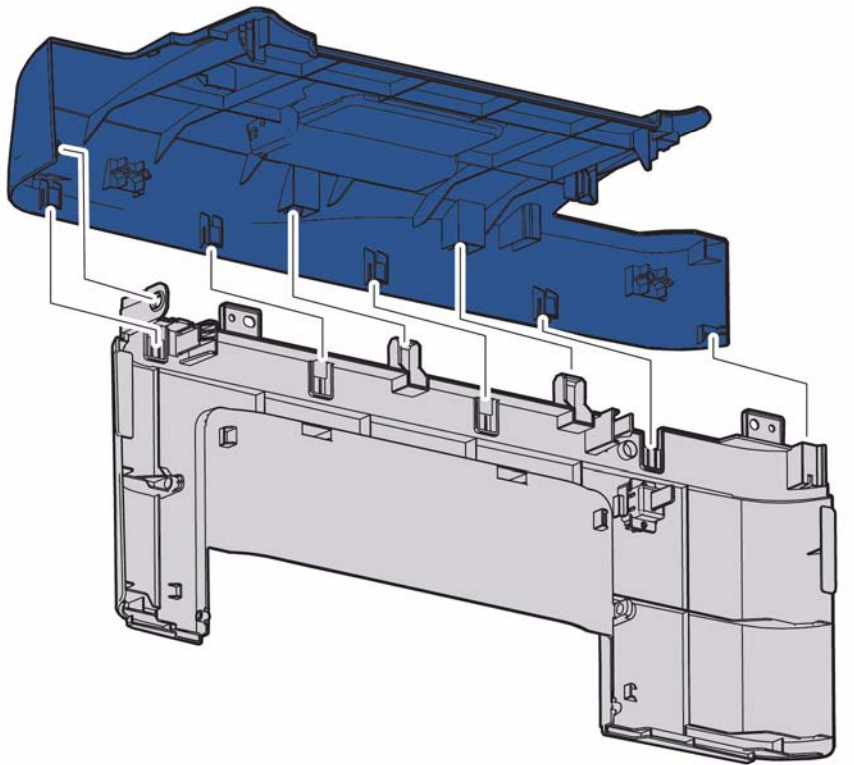

s3655-103

Figure 2 Separate the Top Cover

Replacement

Transfer the Output Tray Extension, REP 19.1.99 to the replacement cover before installation.

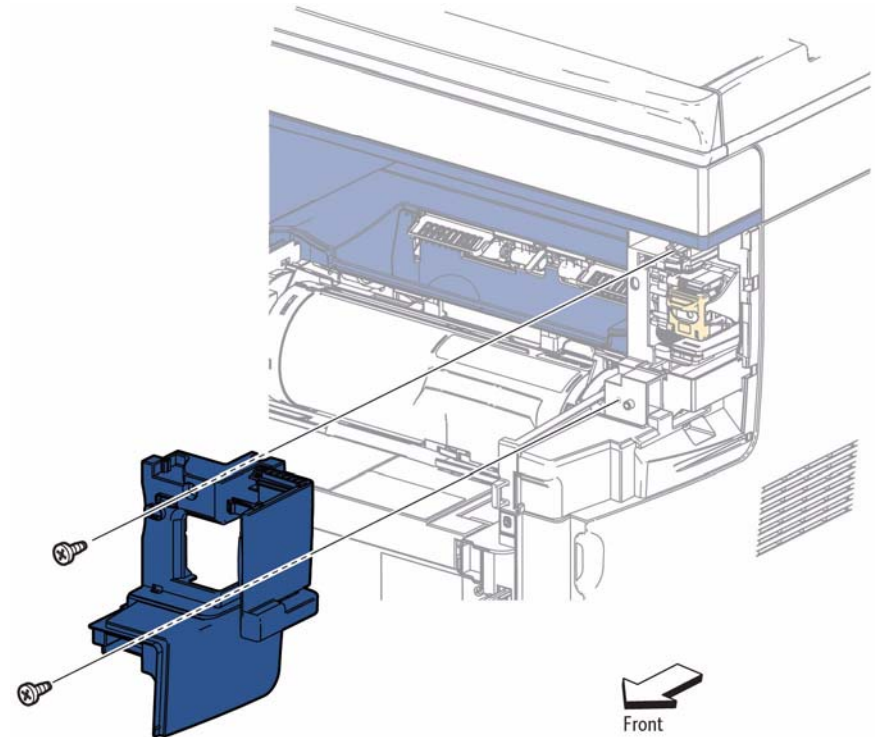

s3655-104

Figure 1 Remove the Stapler Cover Assembly

REP 19.1.99 Output Tray Extension

Parts List on PL 19.1 Item 99

Removal

Refer to Figure 1 to remove the Output Tray Extension by flexing the extension to release the bosses.

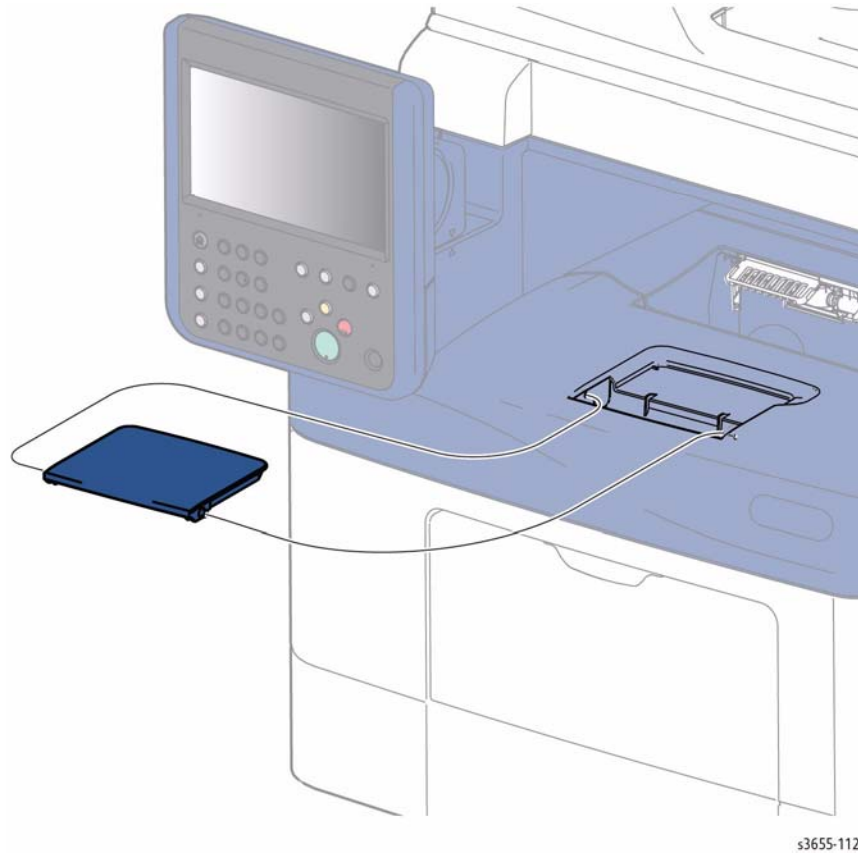

Figure 1 Remove the Output Tray Extension

REP 19.2.1 Left Side Cover

Parts List on PL 19.2 Item 1

Removal

WARNING

Switch off the electricity to the machine. Disconnect the power cord from the customer supply while performing tasks that do not need electricity. Electricity can cause death or injury. Moving parts can cause injury.

WARNING

Do not touch the Fuser while it is hot.

CAUTION

The LVPS Fan is connected to the chassis and cover. Use care when removing the Left Side Cover not to damage the LVPS Fan harness.

1. Open the Rear Cover
2. Remove the Left Rear Cover, REP 19.2.2.
3. Open the Front Cover.
4. Remove the Left UI Base Cover, REP 1.1.6.
5. Refer to Figure 1 to locate and remove 3 screws (silver, tapping, M3, 8mm), and 1 screw (silver, M4, 6mm), release 3 bosses and 1 hook.

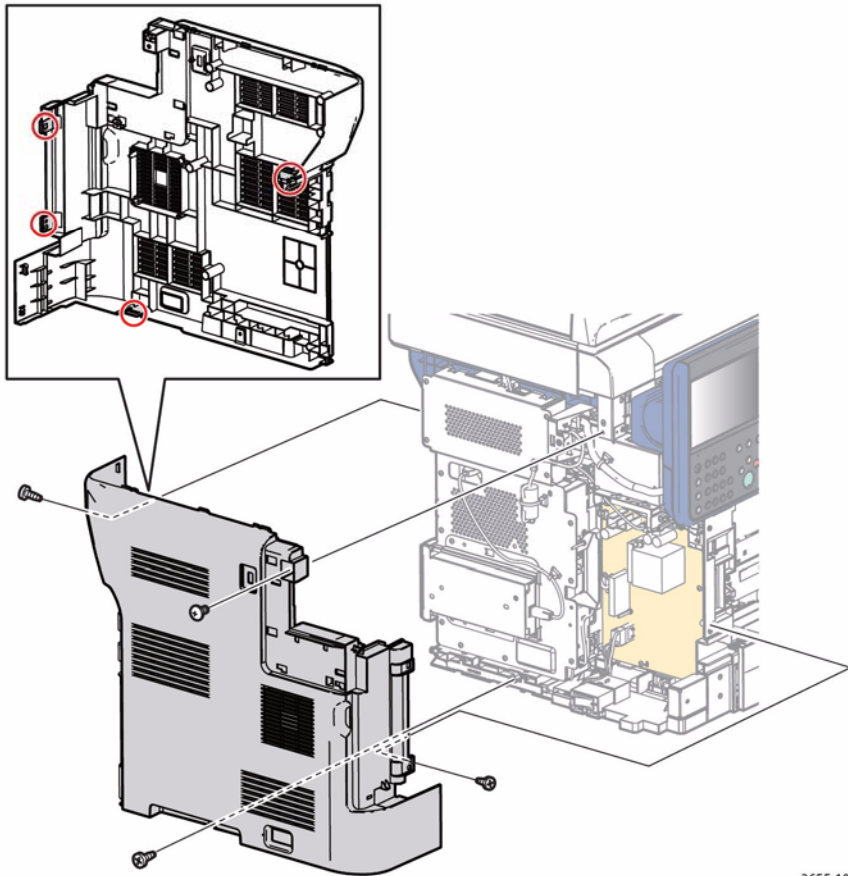

Figure 1 Remove the Left Side Cover

s3655-105

6. Refer to Figure 2 to locate and release the cable tie from the chassis and disconnect the LVPS Fan before removing the cover.

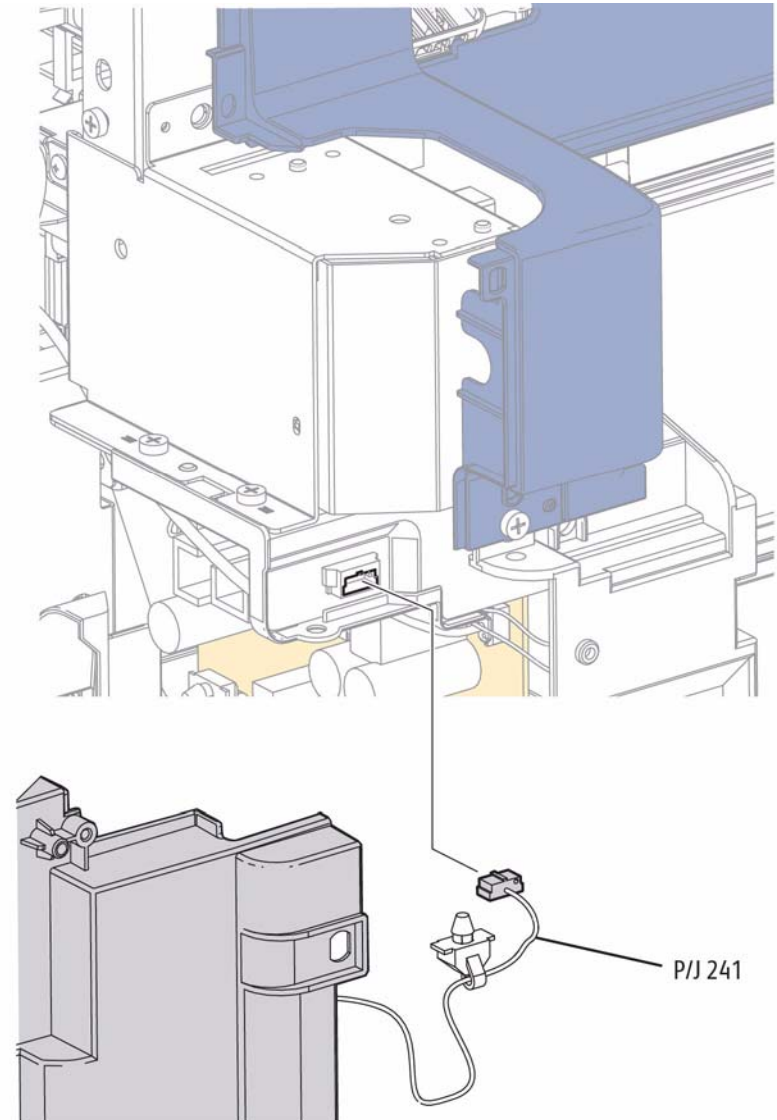

Figure 2 Disconnect the LVPS Fan

s3655-110

Replacement

Transfer the LVPS Fan, REP 4.1.1, to the replacement cover before installation.

REP 19.2.2 Left Rear Cover

Parts List on PL 19.2 Item 2

Removal

WARNING

Switch off the electricity to the machine. Disconnect the power cord from the customer supply while performing tasks that do not need electricity. Electricity can cause death or injury. Moving parts can cause injury.

WARNING

Do not touch the Fuser while it is hot.

1. Disconnect all connections to the printer and remove the Power Cord.
2. Open the Rear Cover.
3. Refer to Figure 1 to locate and remove 1 screw (silver, tapping, 8mm), release 2 bosses and slide to the right to remove the cover.

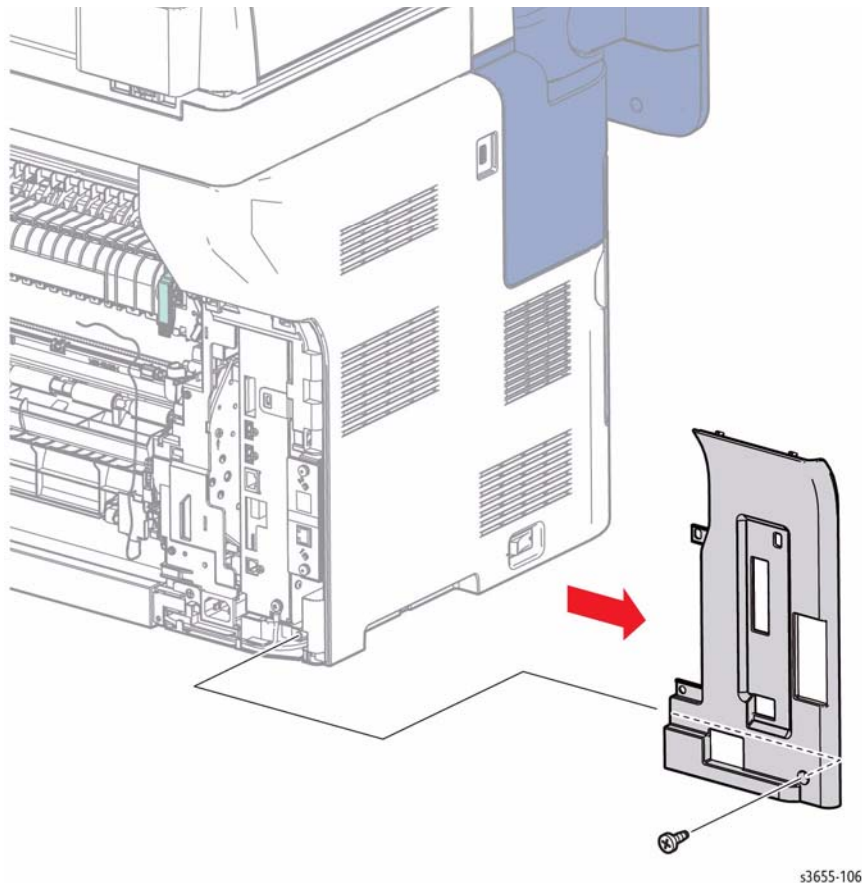

Figure 1 Remove Left Rear Cover

REP 19.2.3 Lower Rear Cover

Parts List on PL 19.2 Item 3

Removal

WARNING

Switch off the electricity to the machine. Disconnect the power cord from the customer supply while performing tasks that do not need electricity. Electricity can cause death or injury. Moving parts can cause injury.

WARNING

Do not touch the Fuser while it is hot.

1. Open the Rear Cover.
2. Open the Front Cover.
3. Remove the Stapler Cover, REP 19.1.11 or Outer Right Cover, REP 19.1.13.
4. Remove the Right Side Cover, REP 19.1.10.
5. Remove the Left Rear Cover, REP 19.2.2.
6. Close the Rear Cover.
7. Refer to Figure 1 to locate and release 1 hook and slide the cover left to remove.

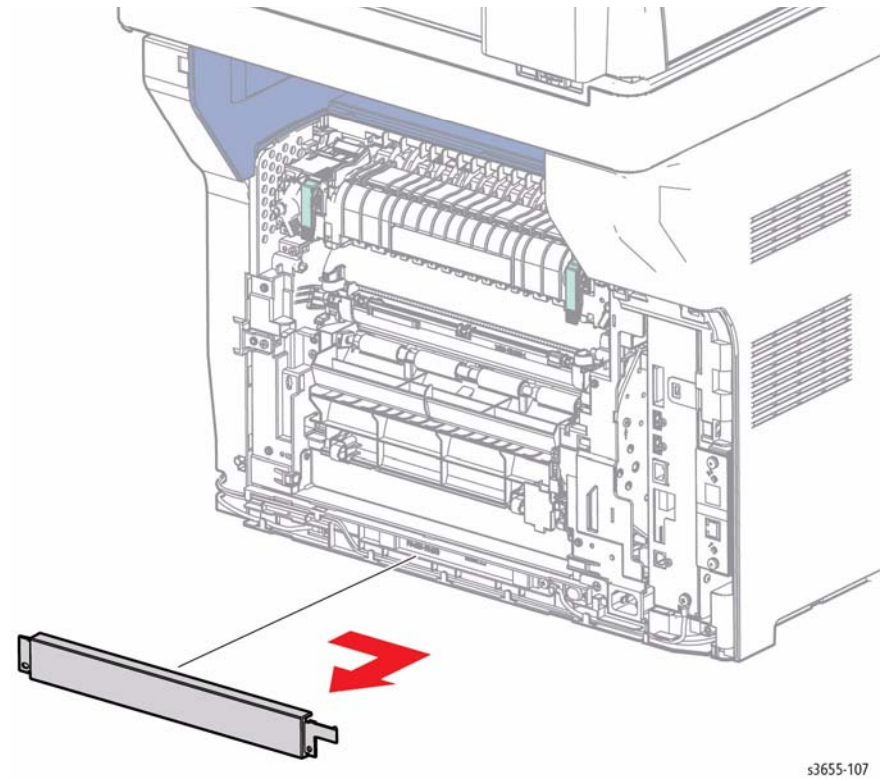

Figure 1 Remove the Lower Rear Cover

REP 19.2.5 SubLV Harness Guide

Parts List on PL 19.2 Item 5

Removal

Access the SubLV Harness Guide by removing the entire IIT (DADF/Scanner) as a unit. Raise the disconnected IIT enough (1inch) to provide clearance to lift the harness guide off the boss that secures it at each end.

WARNING

Switch off the electricity to the machine. Disconnect the power cord from the customer supply while performing tasks that do not need electricity. Electricity can cause death or injury. Moving parts can cause injury.

WARNING

Do not touch the Fuser while it is hot.

CAUTION

Cover the Drum Cartridge after removal to prevent light exposure.

1. Open the Rear Cover
2. Remove the Left Rear Cover, REP 19.2.2.
3. Open the Front Cover.
4. Remove the IIT Top Cover, REP 1.1.1.
5. Remove the IIT Front Cover, REP 1.1.2.
6. Remove the IIT Front Bottom Cover, REP 1.1.3.
7. Remove the Right UI Base Cover, REP 1.1.4.
8. Remove the UI Base Bottom Cover, REP 1.1.5.
9. Remove the Left UI Base Cover, REP 1.1.6.
10. Refer to Figure 1 to locate and remove 1 screw (silver, M3, 6mm) that secures the UI swivel stop.

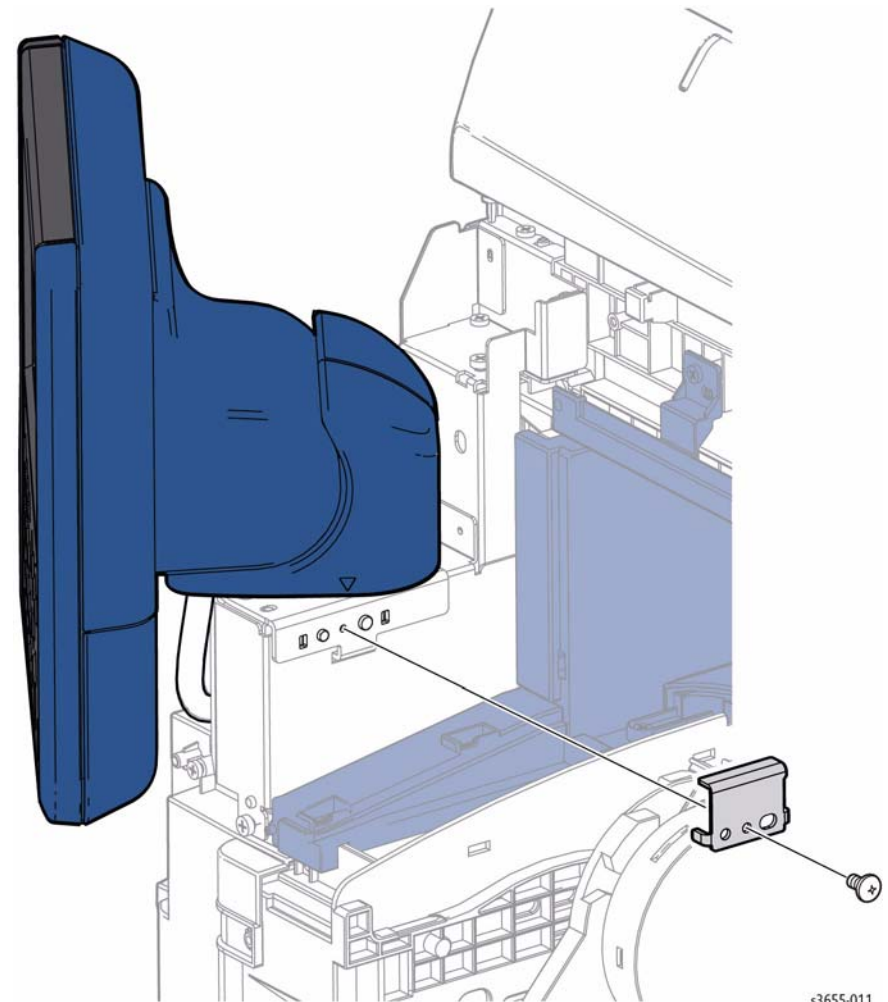

Figure 1 Remove the UI Swivel Stop

11. Remove the Left Side Cover, REP 19.2.1.
12. Remove the Stapler Cover, REP 19.1.11 or Outer Right Cover, REP 19.1.13.
13. Remove the Right Side Cover, REP 19.1.10.
14. Remove the ESS housing cover, REP 18.1.1.
15. Refer to Figure 2 to locate and remove the UI Hinge Assembly with attached Control Panel, REP 1.2.98. Support the Control Panel above the work surface to avoid straining the cable.

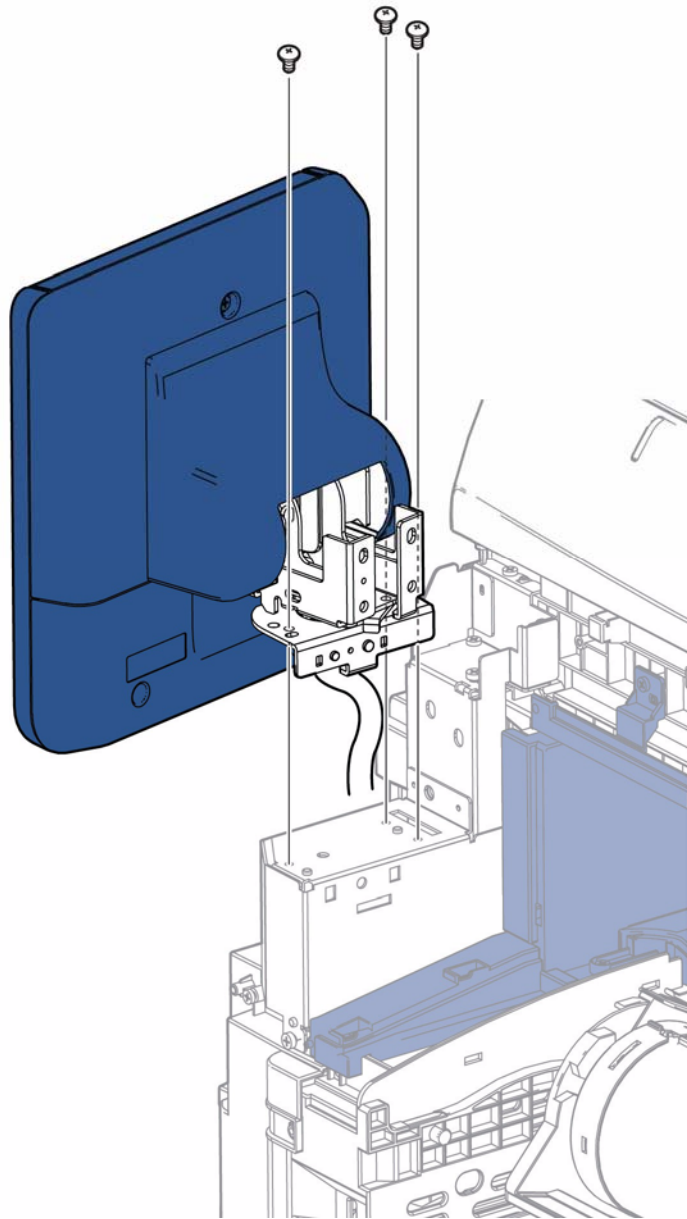
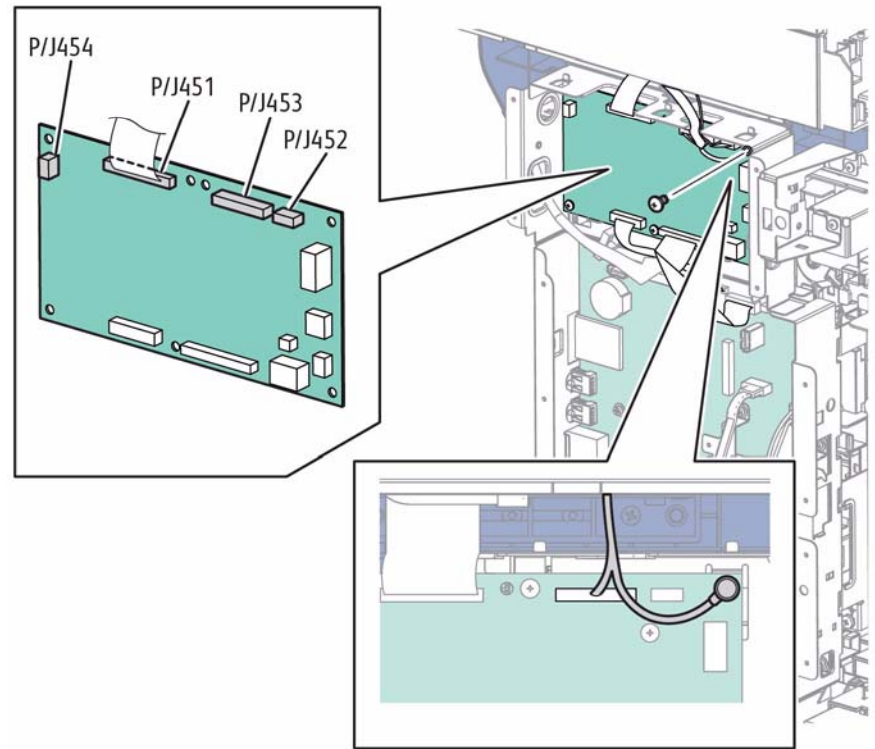

Figure 2 Remove the Control Panel and attached UI Hinge Assembly

s3655-012

16. Refer to Figure 3 to locate and disconnect the DADF and attached ground wire from the IIT Control Board, then release the DADF harness from the ESS housing.



s3655-115

Figure 3 Disconnect the DADF

17. Disconnect the SubLV harness (PJ403) from the IIT Control Board and release the harness from the ESS housing.
18. Disconnect the SubLV harness (PJ802) from the Stapler LVPS and release the harness from the harness guides.
19. Disconnect the Scanner (PJ452 and 454) from the IIT Control Board.

NOTE: Remove the 7 screws shown in Figure 4.

20. Refer to Figure 4 to locate and remove a total of 7 screws:
 - 1 screw (silver, hex-head with flange, M4, 8mm)
 - 2 screws (silver, tapping, M3, 10mm)
 - 1 screw (silver, tapping, M3, 8mm) on the left
 - 3 screws (silver, tapping, 10mm) on the right
21. Slide the Scanner left to release the bosses and lift the IIT Assembly off the chassis.

Replacement

Feed the SubLV harness through the harness guide before installing the guide.

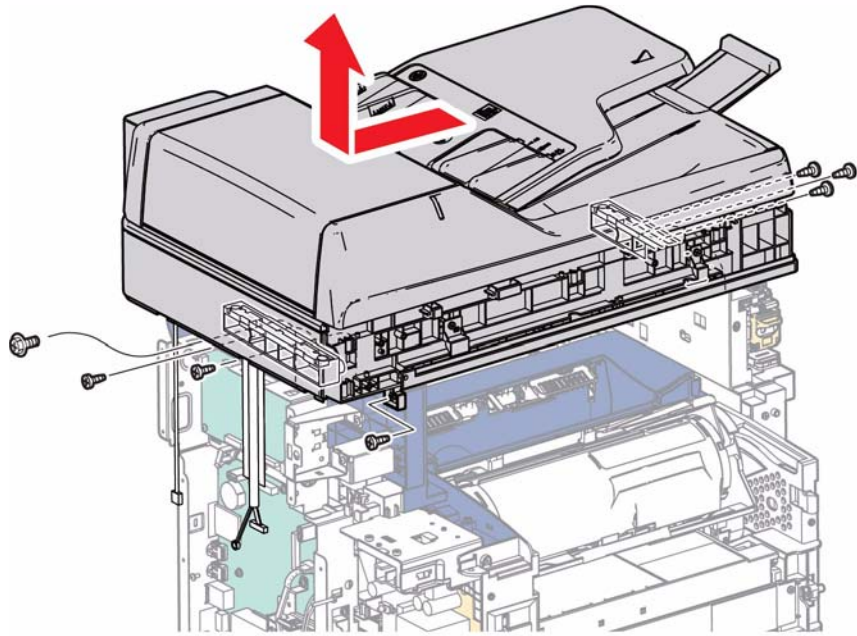

s3655-116

Figure 4 Remove the IIT Assembly

22. Refer to Figure 5 and remove one screw (silver, tapping, M3, 8mm) and raise the SubLV Harness Guide off the boss at each end to remove.

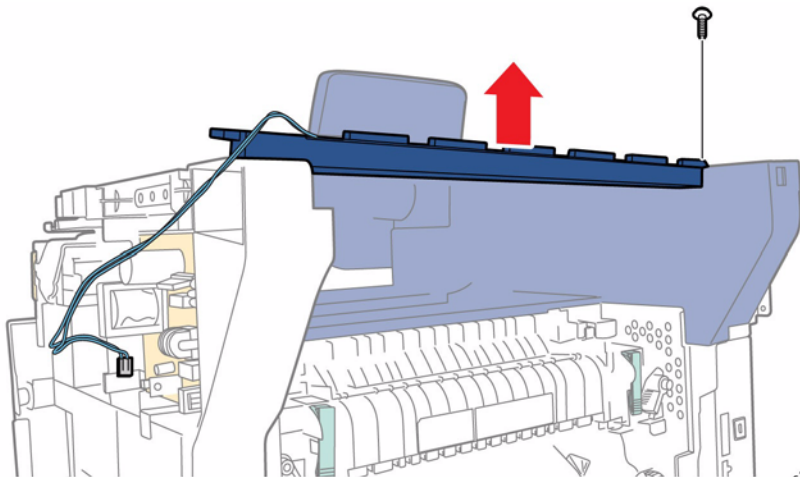

s3655-085

Figure 5 Remove the SubLV Harness Guide

REP 19.2.99 Exit Cover Assembly

Parts List on PL 19.2 Item 99

Removal

WARNING

Switch off the electricity to the machine. Disconnect the power cord from the customer supply while performing tasks that do not need electricity. Electricity can cause death or injury. Moving parts can cause injury.

WARNING

Do not touch the Fuser while it is hot.

CAUTION

Cover the Drum Cartridge after removal to prevent light exposure.

1. Open the Front Cover.
2. Remove the Drum Cartridge, REP 8.1.1.
3. Remove the Stapler Cover, REP 19.1.11 or Outer Right Cover, REP 19.1.13.
4. Open the Rear Cover.
5. Remove the Right Side Cover, REP 19.1.10.
6. Remove the Inner Right Cover, REP 19.1.14.
7. Refer to Figure 1 to locate and remove 2 screws (silver, tapping, M3, 8mm) to remove the Exit Cover Assembly.

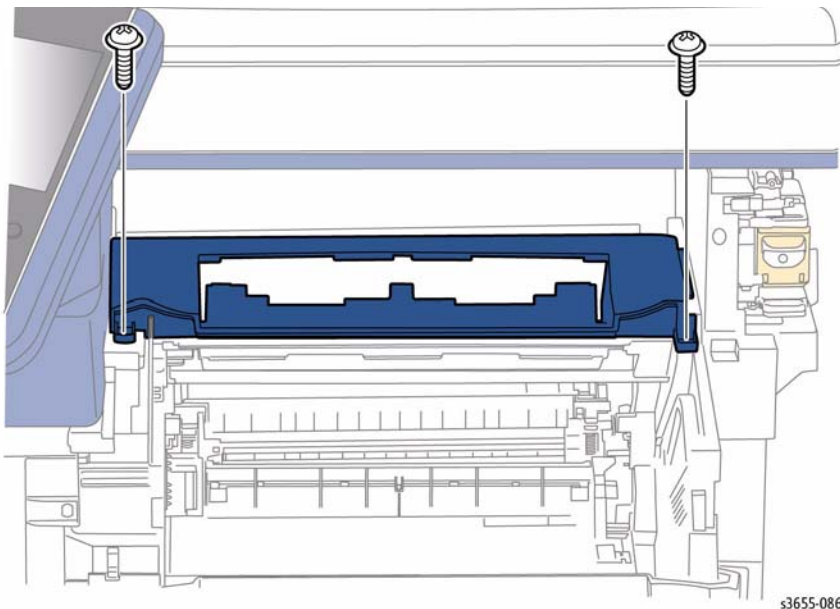

Figure 1 Remove the Exit Cover Assembly

Replacement

Hold the actuator so it will fit through the slot as you position the cover for replacement.

REP 19.3.9 Rear Fan

Parts List on PL 19.3 Item 9

Removal

WARNING

Switch off the electricity to the machine. Disconnect the power cord from the customer supply while performing tasks that do not need electricity. Electricity can cause death or injury. Moving parts can cause injury.

WARNING

Do not touch the Fuser while it is hot.

1. Open the Rear Cover.
2. Release the Stopper Strap and hinge hook from the chassis and allow the Rear Cover to rest on the work surface.
3. Release 1 hook that secures the harness cover and disconnect the Rear Fan near the Rear Cover hinge.
4. Remove the Duplex Chute Assembly, REP 14.1.12.
5. Refer to Figure 1 to locate and release 2 bosses at the top and 2 hooks near the center of the duplex output chute and remove the chute.

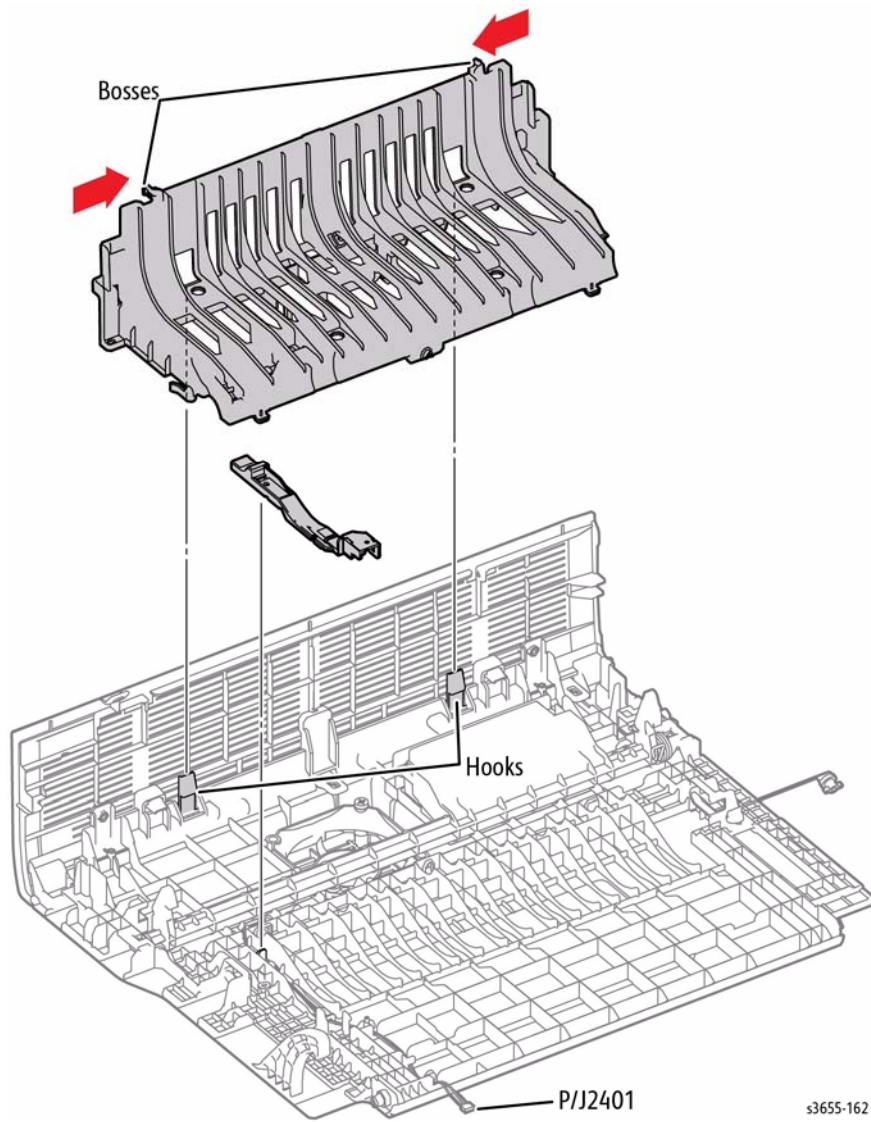

Figure 1 Remove the Duplex Output Chute

6. Release 2 hooks that secure the Rear Fan harness cover and remove the cover.
7. Refer to Figure 2 to remove the rear cover latch.

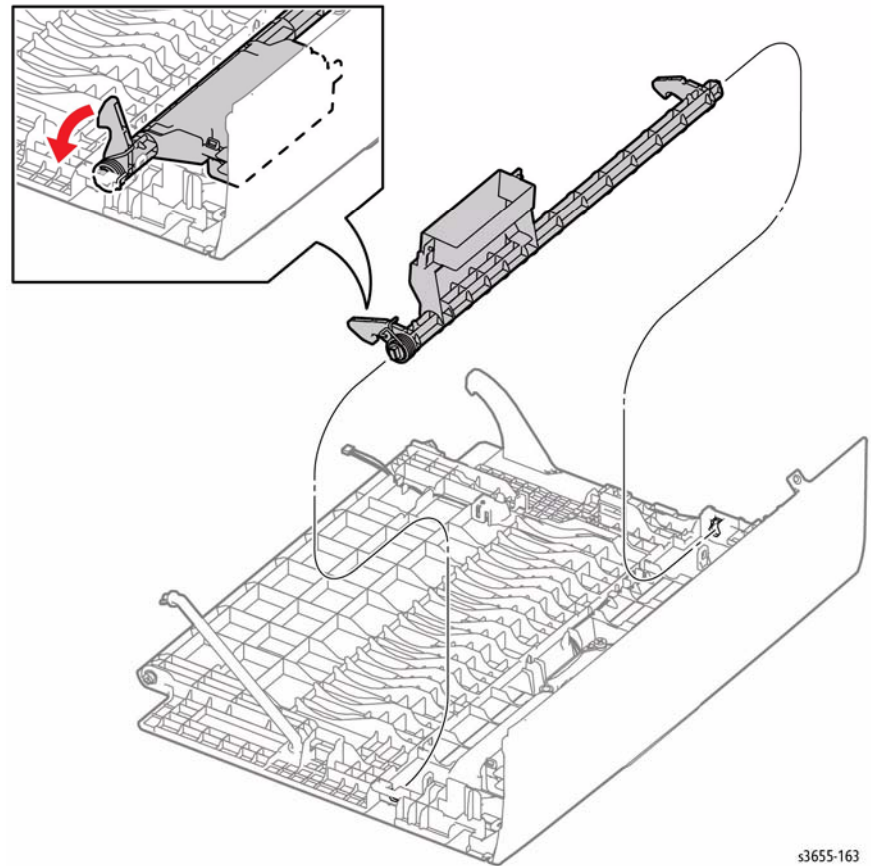

Figure 2 Remove the Rear Cover Latch

8. Refer to Figure 3 to locate and remove 2 screws (silver, tapping, 22mm) to remove the Rear Fan.

REP 19.3.99 Rear Cover Assembly

Parts List on PL 19.3 Item 99

Removal

WARNING

Switch off the electricity to the machine. Disconnect the power cord from the customer supply while performing tasks that do not need electricity. Electricity can cause death or injury. Moving parts can cause injury.

WARNING

Do not touch the Fuser while it is hot.

1. Open the Rear Cover.
2. Release the Stopper Strap and hinge hook from the chassis and allow the Rear Cover to rest on the work surface.

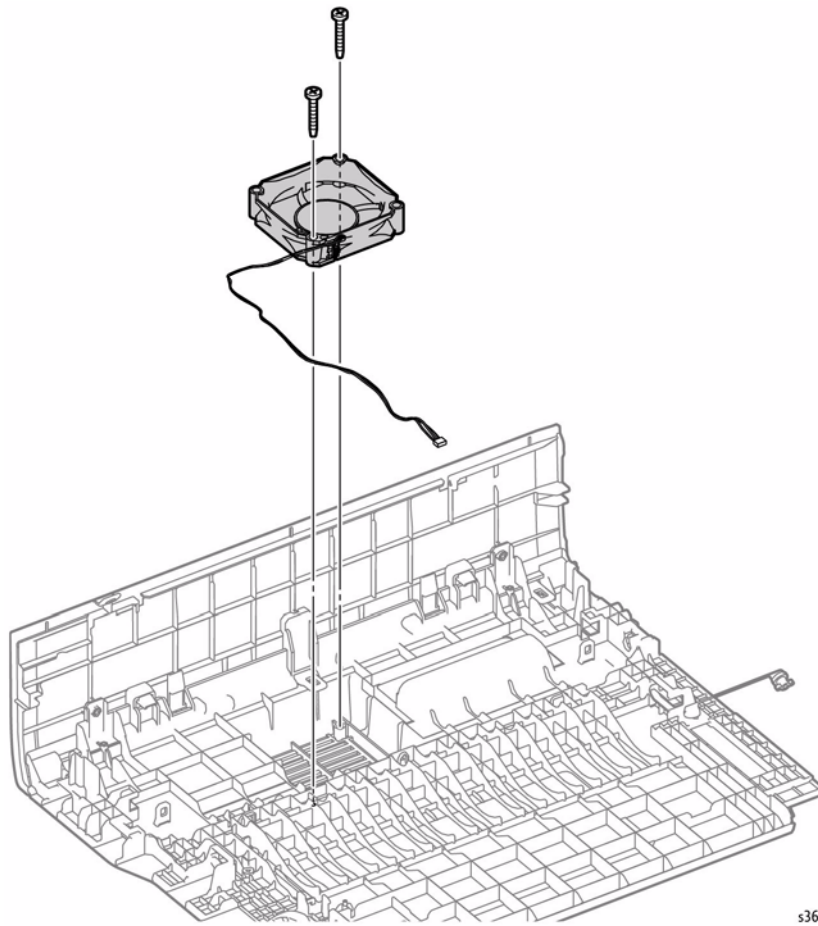

s3655-135

Figure 3 Remove the Rear Fan

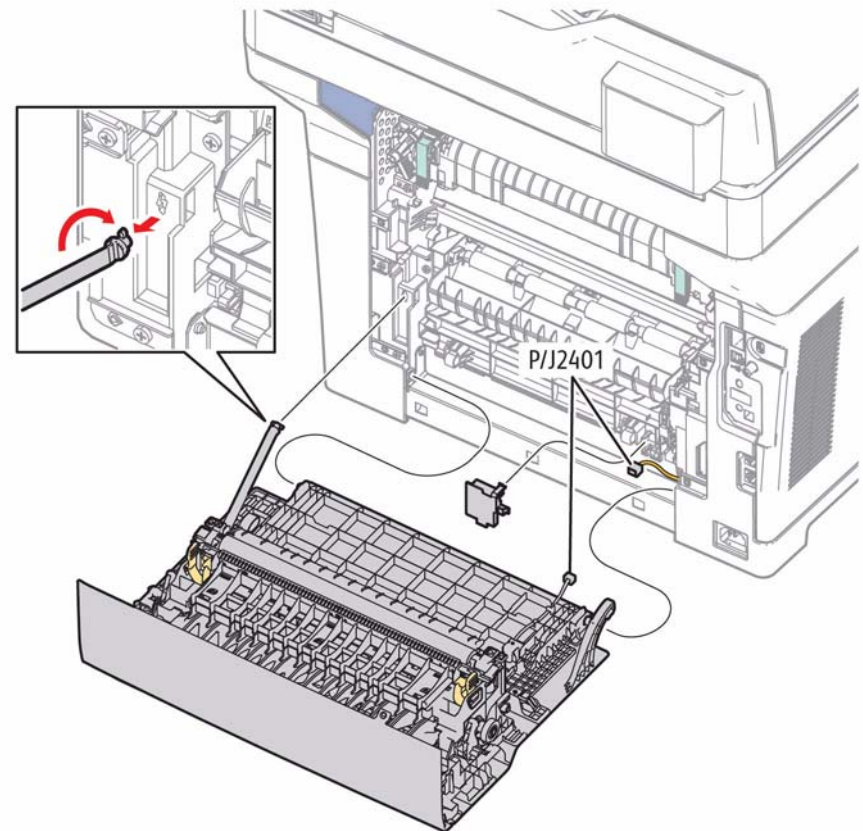

s3655-126

Figure 1 Remove the Rear Cover Assembly

3. Refer to Figure 2 to locate and release the hook that secures the connector cover, then disconnect the Rear Fan. Release the boss on the left side to remove the cover. The ground spring should release from the chassis hook as you remove the cover.

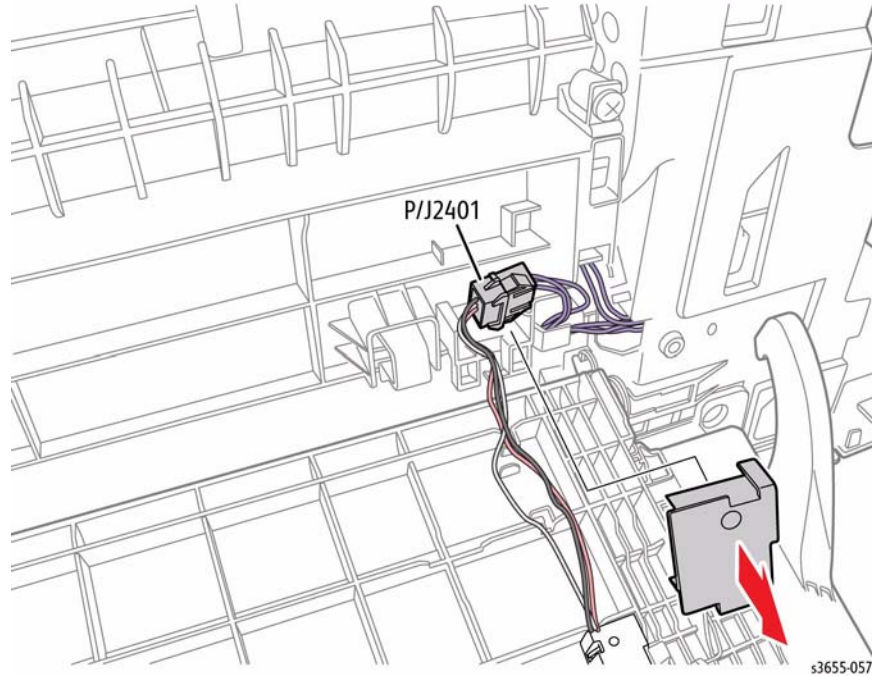

Figure 2 Rear Fan Connection

s3655-057

Replacement

1. Refer to Figure 3 to locate and install the right side and make sure the ground spring engages the hook on the chassis.

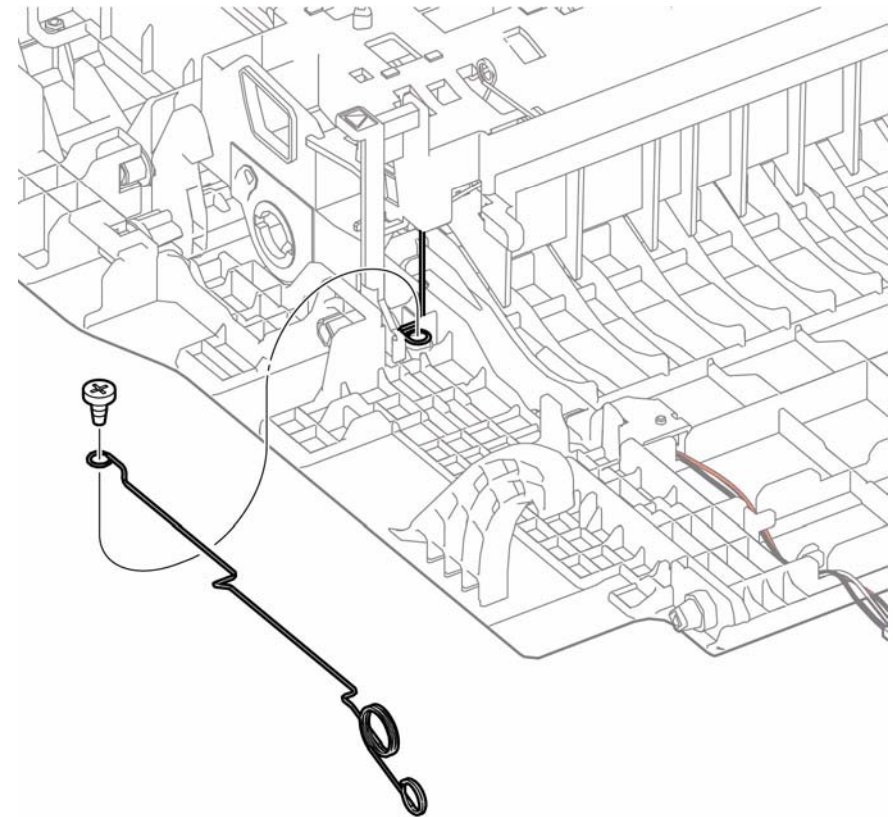

Figure 3 Secure the Rear Cover Ground Springs

s3655-150

2. Reconnect the Rear Fan and install the connector cover.
3. Install the cover on the left side boss and check for any obstruction to Rear Cover motion
4. Transfer the Transfer Roller to the replacement cover.

REP 21.1.1 DADF Assembly

Parts List on PL 21.1 Item 1

Removal

WARNING

Switch off the electricity to the machine. Disconnect the power cord from the customer supply while performing tasks that do not need electricity. Electricity can cause death or injury. Moving parts can cause injury.

WARNING

Do not touch the Fuser while it is hot.

1. Open the Rear Cover
2. Remove the Left Rear Cover, REP 19.2.2.
3. Open the Front Cover.
4. Remove the Left UI Base Cover, REP 1.1.6.
5. Remove the Left Side Cover, REP 19.2.1.
6. Remove the ESS housing cover, REP 18.1.1.
7. Refer to Figure 1 to locate and disconnect the DADF and 1 screw (silver, M3, 6mm) that secures the ground wire from the IIT Control Board.

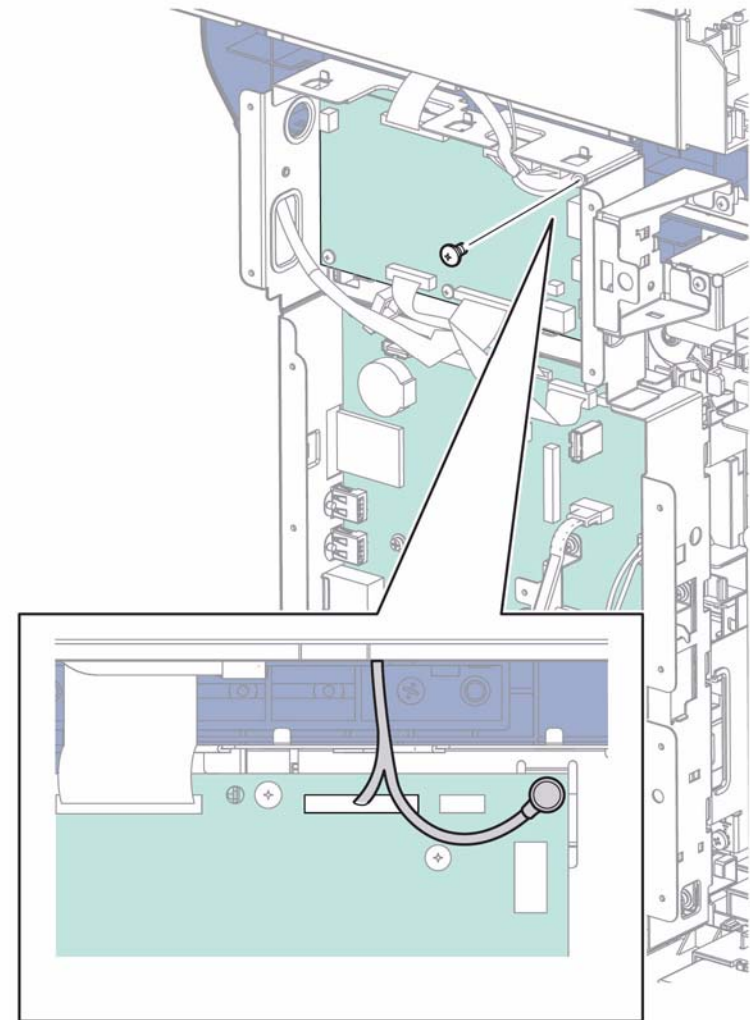

s3655-094

Figure 1 Disconnect the DADF

8. Refer to Figure 2 to locate and remove 2 screws that secure the DADF cable clamps to the underside of the Scanner and remove the clamps from the cable.

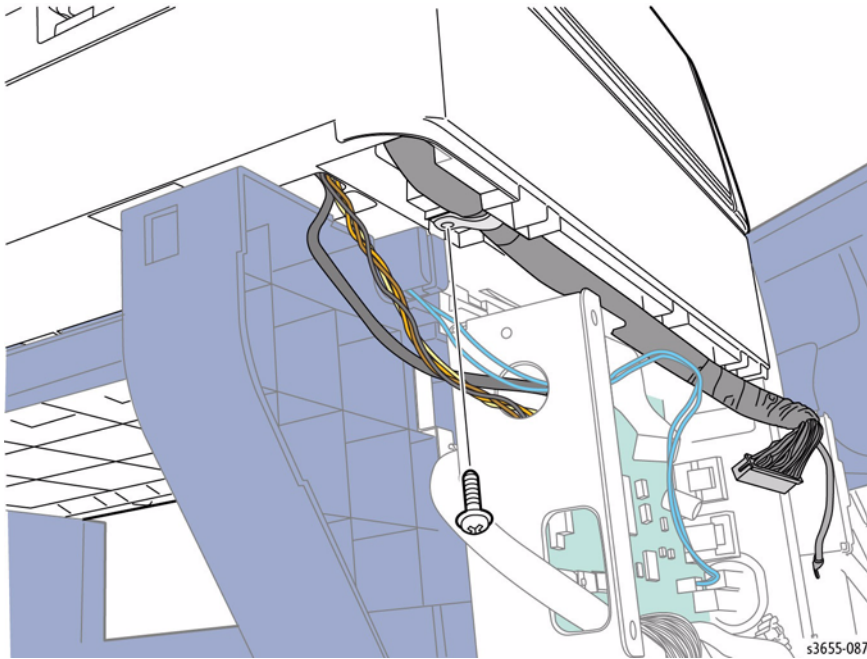

Figure 2 Release the DADF Harness

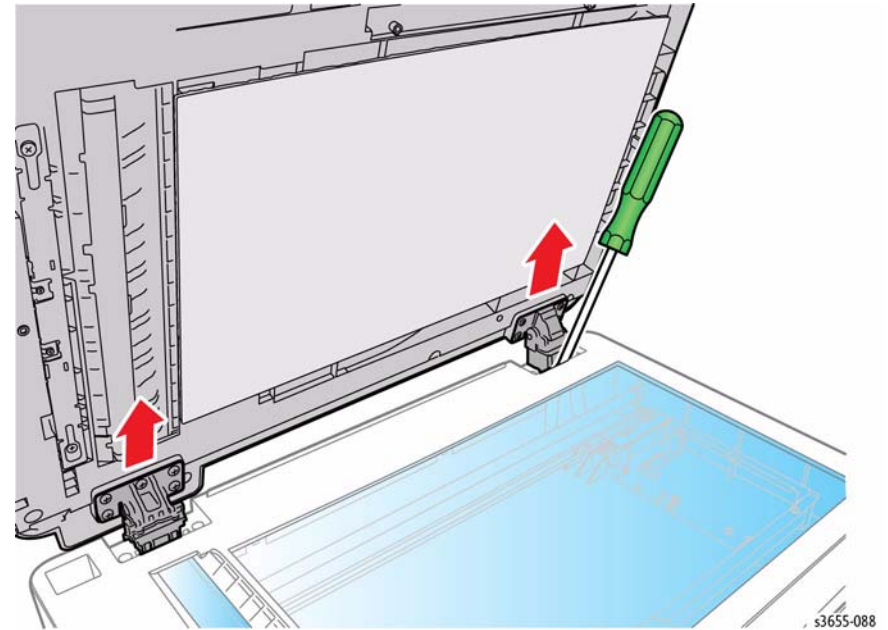

Figure 3 Release the DADF Hinge

9. Open the DADF.
10. Pull the DADF cable up through the opening in the Scanner.
11. Refer to Figure 3 and lift the DADF to expose the hinges. Using a small, flat-bladed screwdriver, release the hook located on the front of the right hinge to remove the DADF.

REP 21.1.9 DADF Hinges

Parts List on PL 21.1 Item 9, PL 21.1 Item 10

Removal

1. Remove the DADF, REP 21.1.1, and rest upside down on the work surface.
2. Refer to Figure 1 to locate and remove 4 screws (silver, tapping, 8mm) to remove the Right Hinge or 5 screws (silver, tapping, 8mm) to remove the Left Hinge

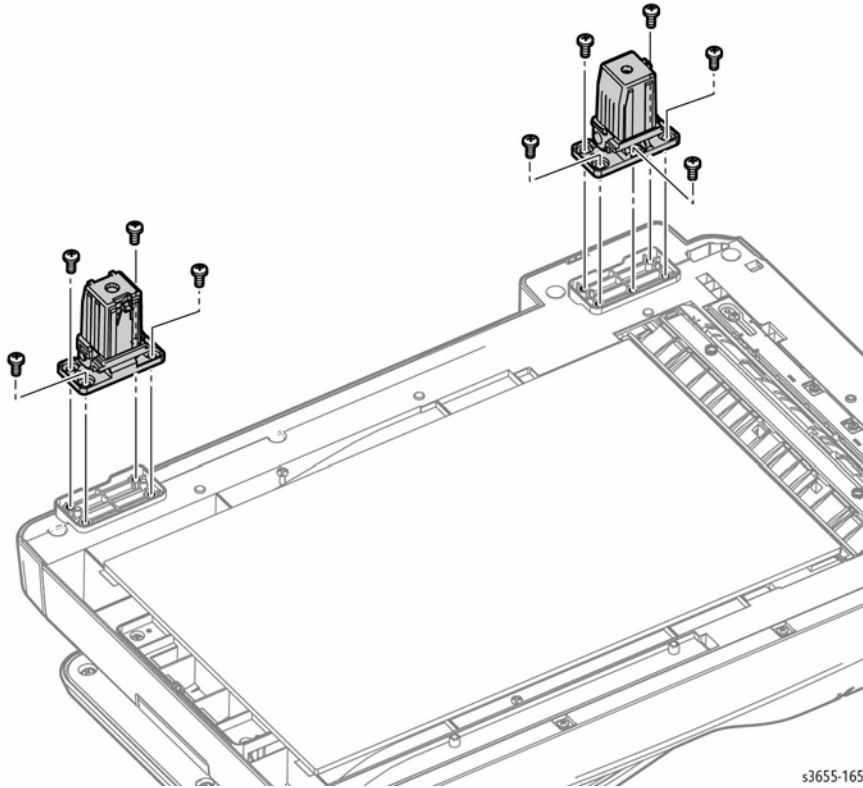

Figure 1 Remove the DADF Hinges

REP 21.1.11 DADF Input Tray Assembly

Parts List on PL 21.1 Item 11

Removal

WARNING

Switch off the electricity to the machine. Disconnect the power cord from the customer supply while performing tasks that do not need electricity. Electricity can cause death or injury. Moving parts can cause injury.

1. Remove the DADF, REP 21.1.1.
2. Refer to Figure 1 to locate and remove 4 screws (silver, tapping, 8mm) from the bottom of the DADF rear cover and release 1 hook on the tray to remove the cover.

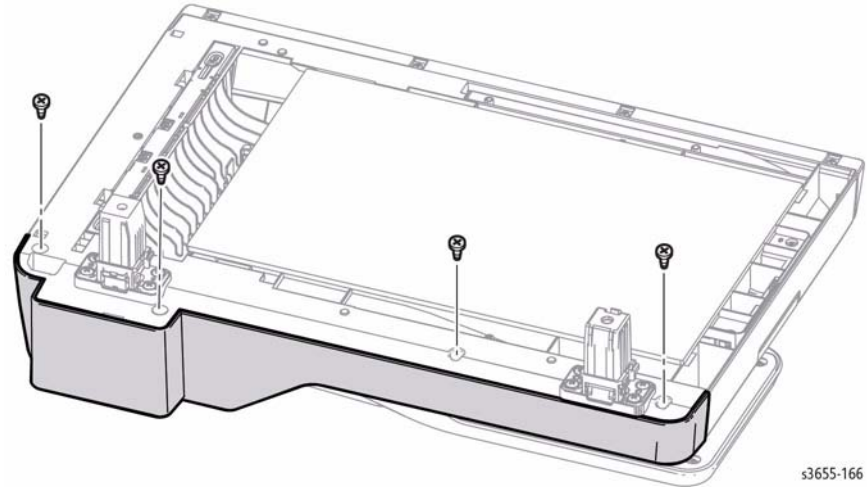

Figure 1 Remove the Rear Cover screws

3. Turn the DADF upright and refer to Figure 2 to raise the DADF Top Cover and Input Tray Assembly to release the rear cover.

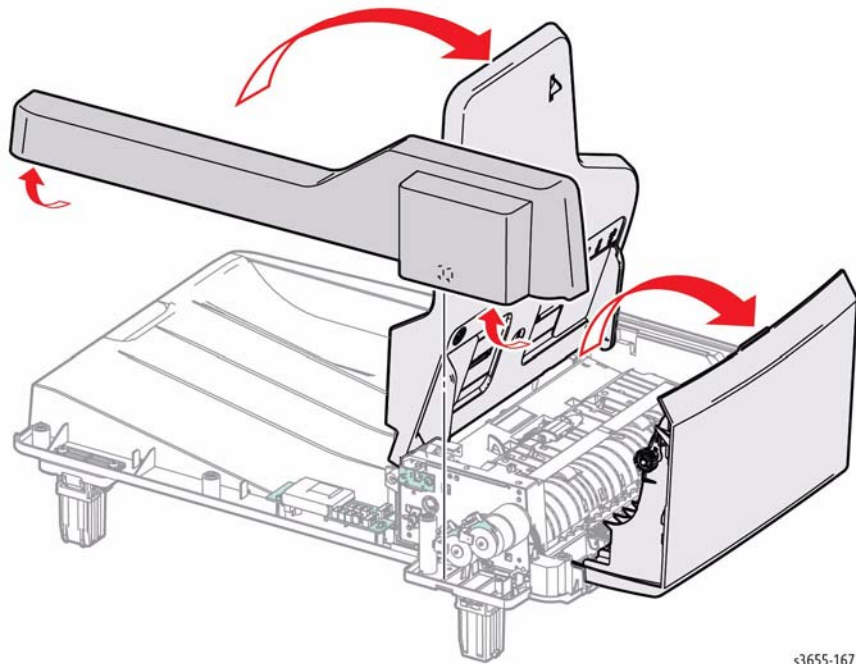

Figure 2 Remove the DADF Rear Cover

s3655-167

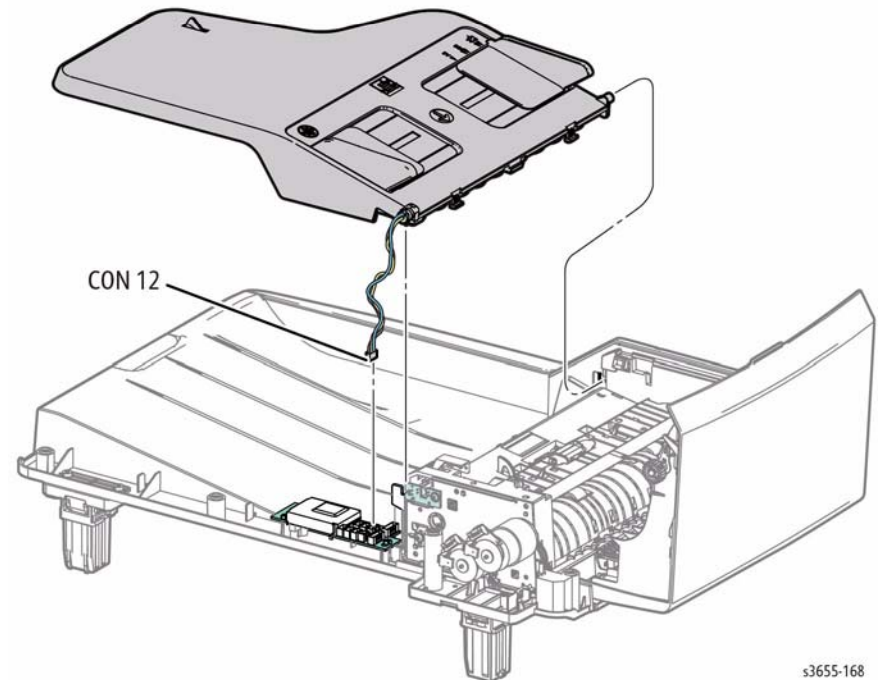

Figure 3 Remove the DADF Input Tray

s3655-168

4. Refer to Figure 3 to locate and cut the cable tie on the tray harness, then disconnect the tray. Lift and move right to remove the tray.

Replacement

Route the tray harness through the slot provided in rear boss.

REP 21.1.14 Scanner

Parts List on PL 21.1 Item 14

Removal

WARNING

Switch off the electricity to the machine. Disconnect the power cord from the customer supply while performing tasks that do not need electricity. Electricity can cause death or injury. Moving parts can cause injury.



WARNING

Do not touch the Fuser while it is hot.

1. Open the Rear Cover.
2. Remove the Left Rear Cover, REP 19.2.2.
3. Open the Front Cover.
4. Remove the IIT Top Cover, REP 1.1.1.
5. Remove the IIT Front Cover, REP 1.1.2.
6. Remove the IIT Front Bottom Cover, REP 1.1.3.
7. Remove the Right UI Base Cover, REP 1.1.4.
8. Remove the UI Base Bottom Cover, REP 1.1.5.
9. Remove the Left UI Base Cover, REP 1.1.6.
10. Remove the Left Side Cover, REP 19.2.1.
11. Remove the Stapler Cover, REP 19.1.11 or Outer Right Cover, REP 19.1.13.
12. Remove the Right Side Cover, REP 19.1.10.
13. Remove the ESS housing cover, REP 18.1.1.
14. Remove the UI Hinge Assembly with attached Control Panel, REP 1.2.98.
15. Remove the DADF, REP 21.1.1.
16. Disconnect the Scanner (PJ452 and 454) from the IIT Control Board.
17. Refer to Figure 1 to locate and remove a total of 7 screws:
 - 1 screw (silver, hex-head with flange, M4, 8mm)
 - 2 screws (silver, tapping, M3, 10mm)
 - 1 screw (silver, tapping, M3, 8mm) on the left
 - 3 screws (silver, tapping, 10mm) on the right
18. Slide the Scanner left to release the bosses and remove.

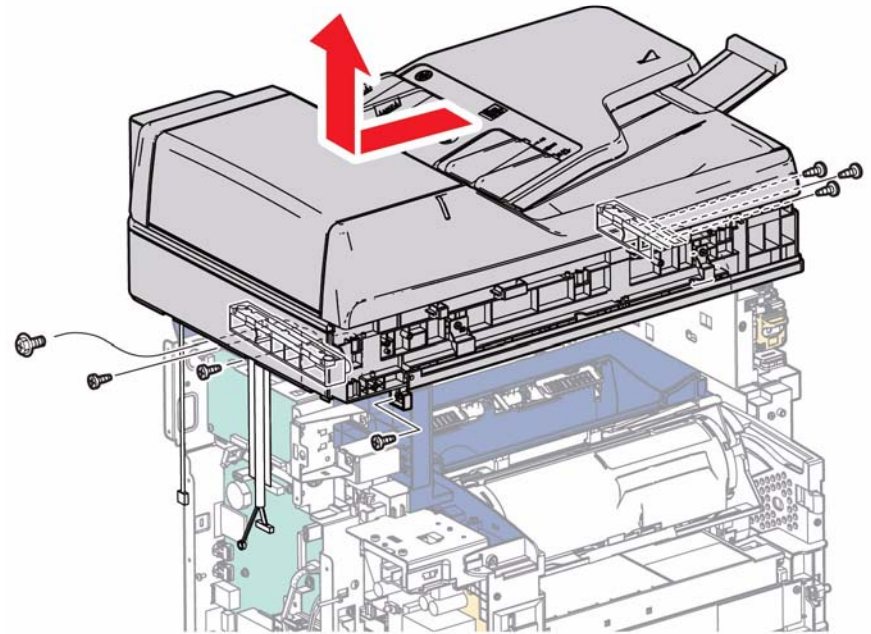

s3655-116

Figure 1 Remove the Scanner

REP 21.1.97 DADF Pick-up Assembly

Parts List on PL 21.1 Item 97

Removal

1. Open the DADF Top Cover.
2. Remove the guides from the Pick-up Assembly shaft.
3. Refer to Figure 1 to locate and release the bearing locks at each end of the shaft to remove the assembly.

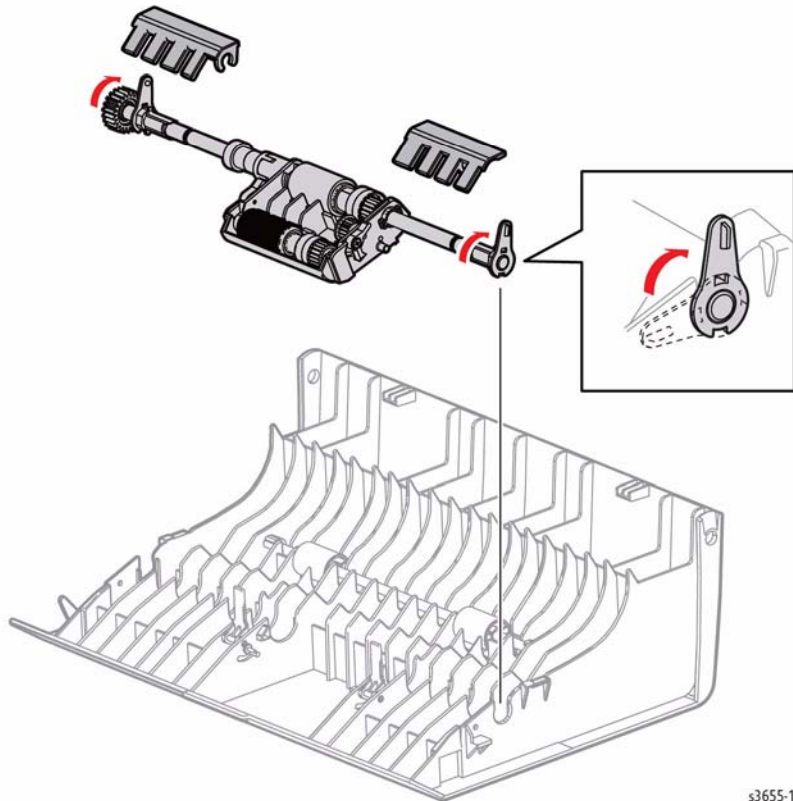

Figure 1 Remove the DADF Pick-up Assembly

4. Refer to Figure 2 to release 2 clips and remove the Separation Pad.

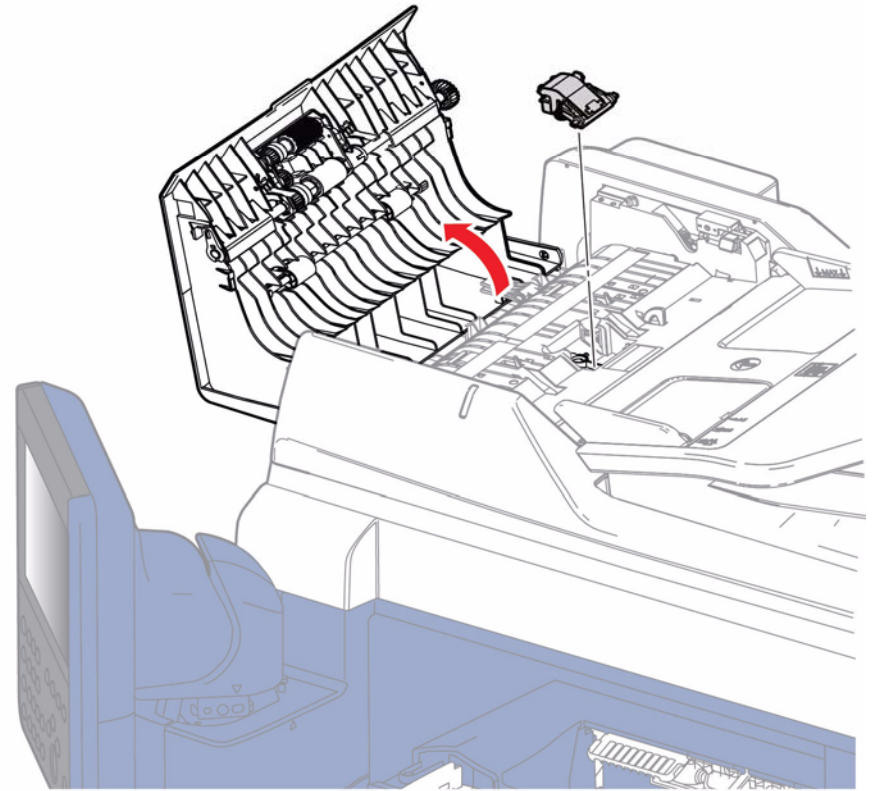

Figure 2 Remove the DADF Retard Assembly

Replacement

Install the pick-up guides on the replacement assembly.

REP 21.1.98 DADF Top Cover Assembly

Parts List on PL 21.1 Item 98

Removal

WARNING

Switch off the electricity to the machine. Disconnect the power cord from the customer supply while performing tasks that do not need electricity. Electricity can cause death or injury. Moving parts can cause injury.

1. Open the DADF Top Cover.
2. Refer to Figure 1 to locate and release the cover from the hinge bosses to remove.

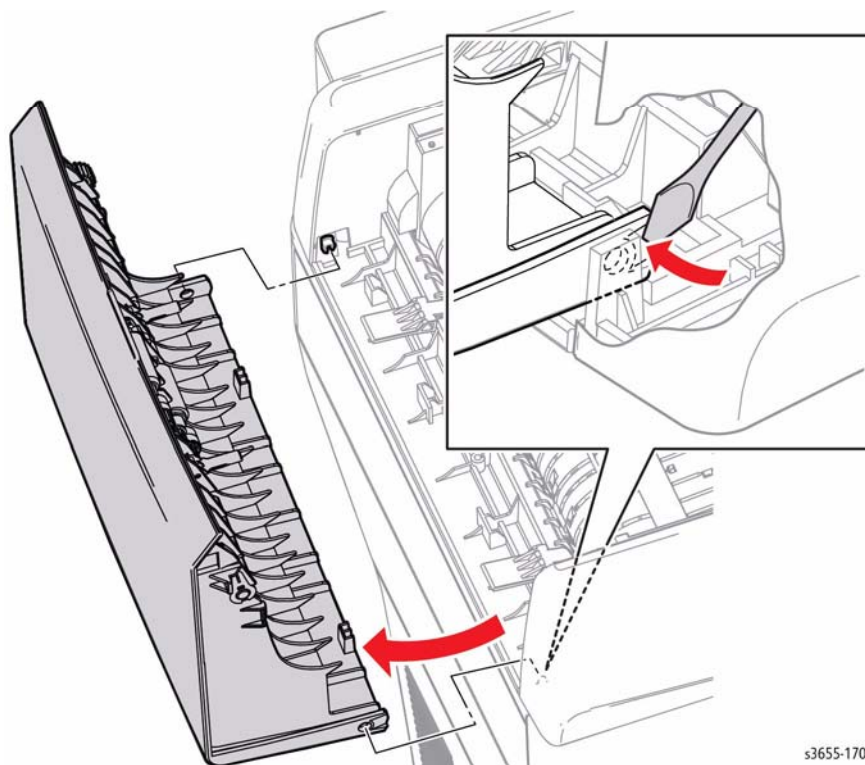

Figure 1 Remove the DADF Top Cover

3. Remove the Pick-up Assembly, REP 21.1.97 and transfer to the replacement cover.

Replacement

Refer to Figure 2 and raise the Top Cover tabs (black) before installing the Top Cover.

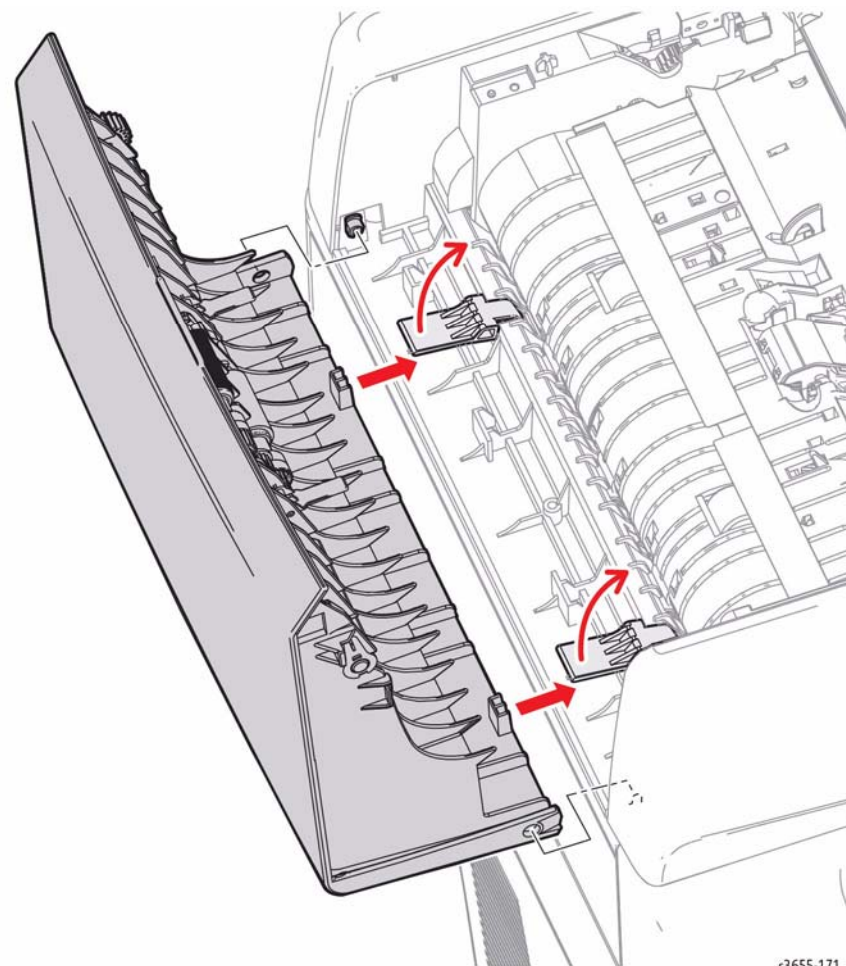

Figure 2 Install the DADF Top Cover

ADJ. 8.1 Lead Edge Registration

Purpose

To adjust the Lead edge registration for each tray, based on the paper weight being used.

Adjustment

Refer to **Table 1** to determine which NVM to adjust.

Place the Geometric Test Pattern (82E8220) on the Platen Glass correctly and make copies.

Enter the Diagnostic Mode (GP1).

Go to the Adjustments tab, and select DC131.

1. Enter Service Diagnostics, GP 1.
2. Select the Adjustments tab.
3. Select dC131 NVM Read/Write.
4. Select the appropriate NVMID.
5. View or edit the NVM value as necessary.
6. When the values have been changed, cycle system power to verify changes made to NVM.

Run copies to verify the Lead Edge Registration is now correct for the tray and paper weight being adjusted.

Table 1		
Speed	Tray	NVM ID
Simplex ≤ 160 gsm	MSI	742-532
	Tray 1	742-533
	Trays 2-4	742-534
	Duplex	742-535
Simplex > 160 gsm	MSI	742-536
	Tray 1	742-537
	Trays 2-4	742-538
	Duplex	742-539
Duplex	MSI	742-540
	Tray 1	742-541
	Trays 2-4	742-542
	Duplex	742-543

5 Parts Lists

Control Panel			
PL 1.1 UI Base	5-3	PL 18.2 Electrical (2/4)	5-25
PL 1.2 Console UI	5-4	PL 18.3 Electrical (3/3)	5-26
		PL 18.4 Electrical (4/4)	5-27
Laser Unit		Covers	
PL 2.1 ROS	5-5	PL 19.1 Covers (1/3)	5-28
		PL 19.2 Covers (2/3)	5-29
		PL 19.3 Covers (3/3)	5-30
Drive		IIT	
PL 3.1 Drive	5-6	PL 21.1 IIT/DADF	5-31
NOHAD and Links			
PL 4.1 NOHAD & Links	5-7		
Dispense			
PL 5.1 Dispenser	5-8		
Transfer			
PL 6.1 Transfer	5-9		
Fuser			
PL 7.1 Fuser	5-10		
Xerographic			
PL 8.1 Xerographics	5-11		
Tray 550			
PL 9.2 Tray 550	5-12		
Option 550-Sheet Feeder			
PL 11.1 Option Feeder 550 (1/4)	5-13		
PL 11.2 Option Feeder 550 (2/4)	5-14		
PL 11.3 Option Feeder 550 (3/4)	5-15		
PL 11.4 Option Feeder 550 (4/4)	5-16		
MSI Bypass Tray			
PL 13.1 MSI (1/2)	5-17		
PL 13.2 MSI (2/2)	5-18		
Duplex			
PL 14.1 Duplex Chute	5-19		
Registration			
PL 15.1 Registration (1/3)	5-20		
PL 15.2 Registration (2/3)	5-21		
PL 15.3 Registration (3/3)	5-22		
Exit			
PL 17.1 Exit	5-23		
Electrical			
PL 18.1 Electrical (1/4)	5-24		

PL 1.1 UI Base

Item	Part	Description
1	822E04720	CVR IIT Front Top
2	822E04700	CVR IIT Front
3	-	CVR IIT Front Bottom
4	822E04661	CVR UI Base Right Upper
5	-	CVR UI Base Right Bottom
6	822E04621	CVR UI Base Left
7	-	Frame Assy Neck UI

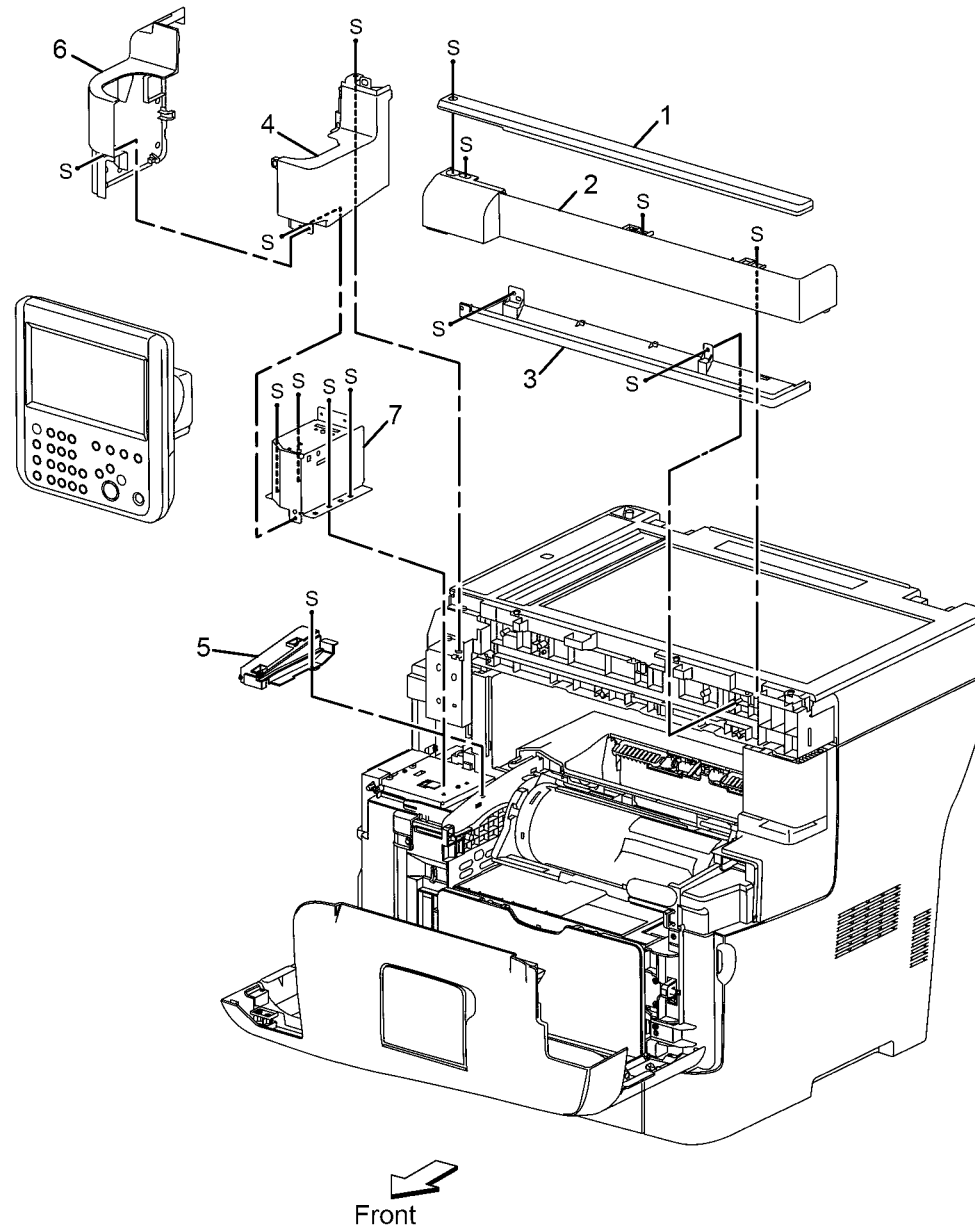

0501001A-BUR

PL 1.2 Console UI

Item	Part	Description
1	848K91372	Console Assy UI 220v
-	848K91336	Console Assy UI 110v
2	822E09640	CVR UI Rear Upper
3	-	CVR UI Hinge Left
4	-	CVR UI Hinge Right
5	-	CVR UI Rear Lower (p/o item 98)
6	-	UI Assy Hinge Neck (p/o item 98)
7	-	UI Stopper Swivel (p/o item 98)
8	-	Guide UI Cable (p/o item 98)
9	-	UI Cable
98	604K90601	Kit UI Assy Hinge

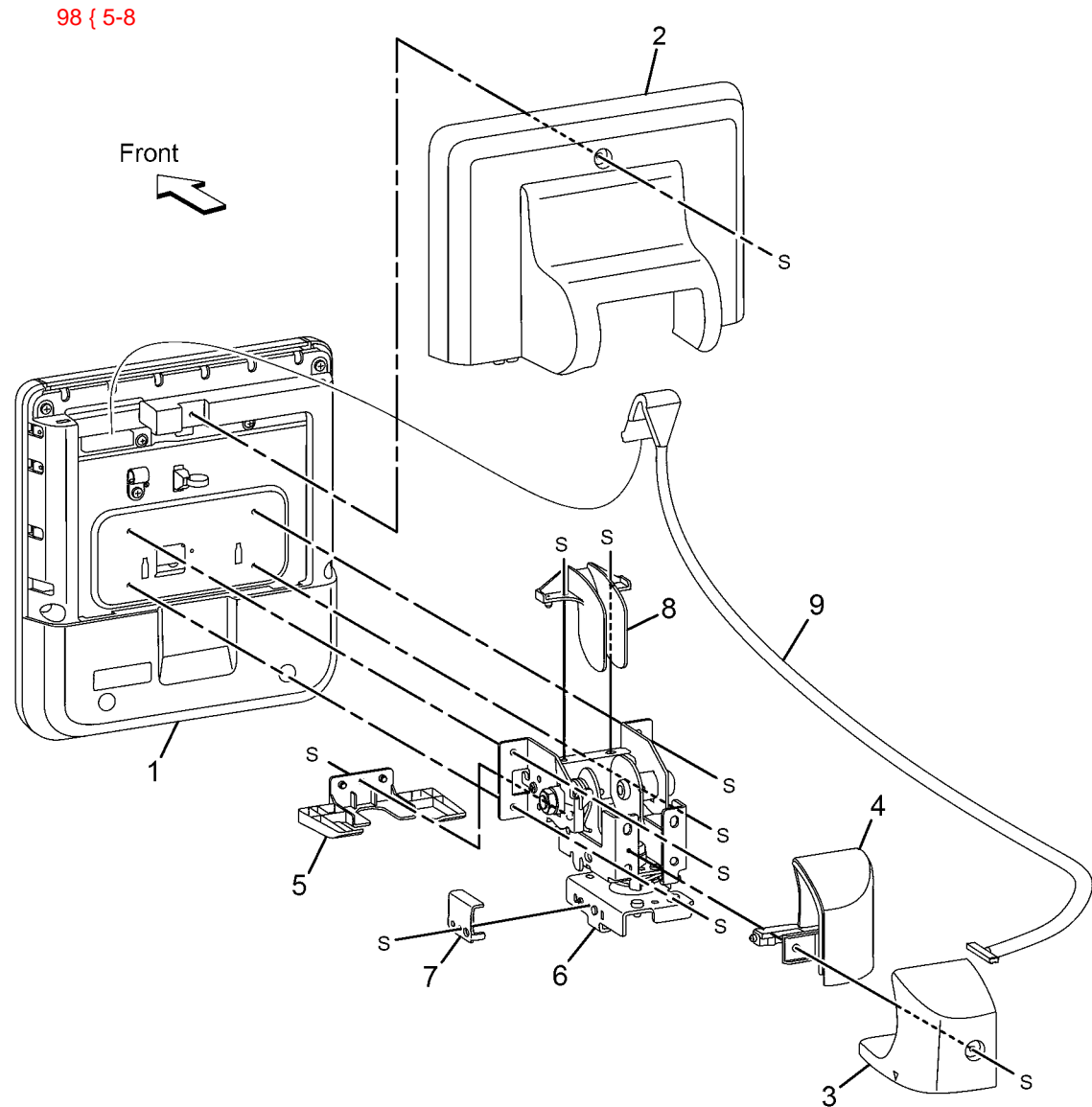

0501002A-BUR

PL 2.1 ROS

Item	Part	Description
1	062K24263	Laser Unit (ROS)
2	-	Harness ROS-MCU
3	-	Harness Video
4	-	Laser Unit

1 { 2-4

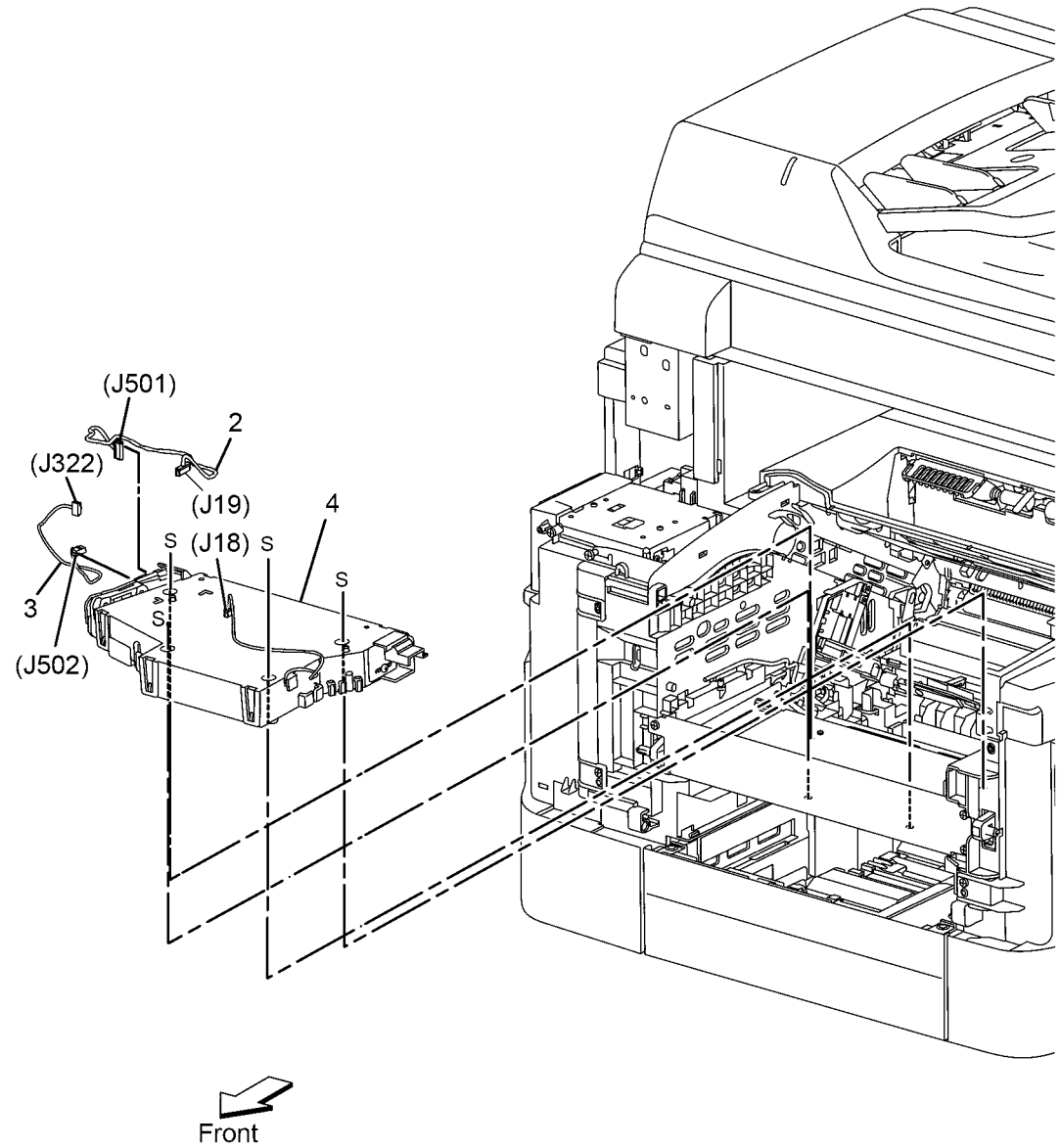

0502001A-BUR

PL 3.1 Drive

Item	Part	Description
1	007K20850	Drive Assembly Main
2	007K18912	Holder Assembly Drive Exit Out
3	604K80770	Holder Assembly Drive Exit In
4	019E83450	Holder Gear Dup
5	-	Gear Dup In
6	-	Clutch Assembly Exit T21
7	-	Clutch Assembly Invet T24
8	-	Gear E3 Z
9	-	Gear E3
10	-	Chassis ESS Bottom
11	-	Exit Invert Drive Assy
12	-	Exit Drive Assy

2 { 7-9, 12
3 { 6, 11

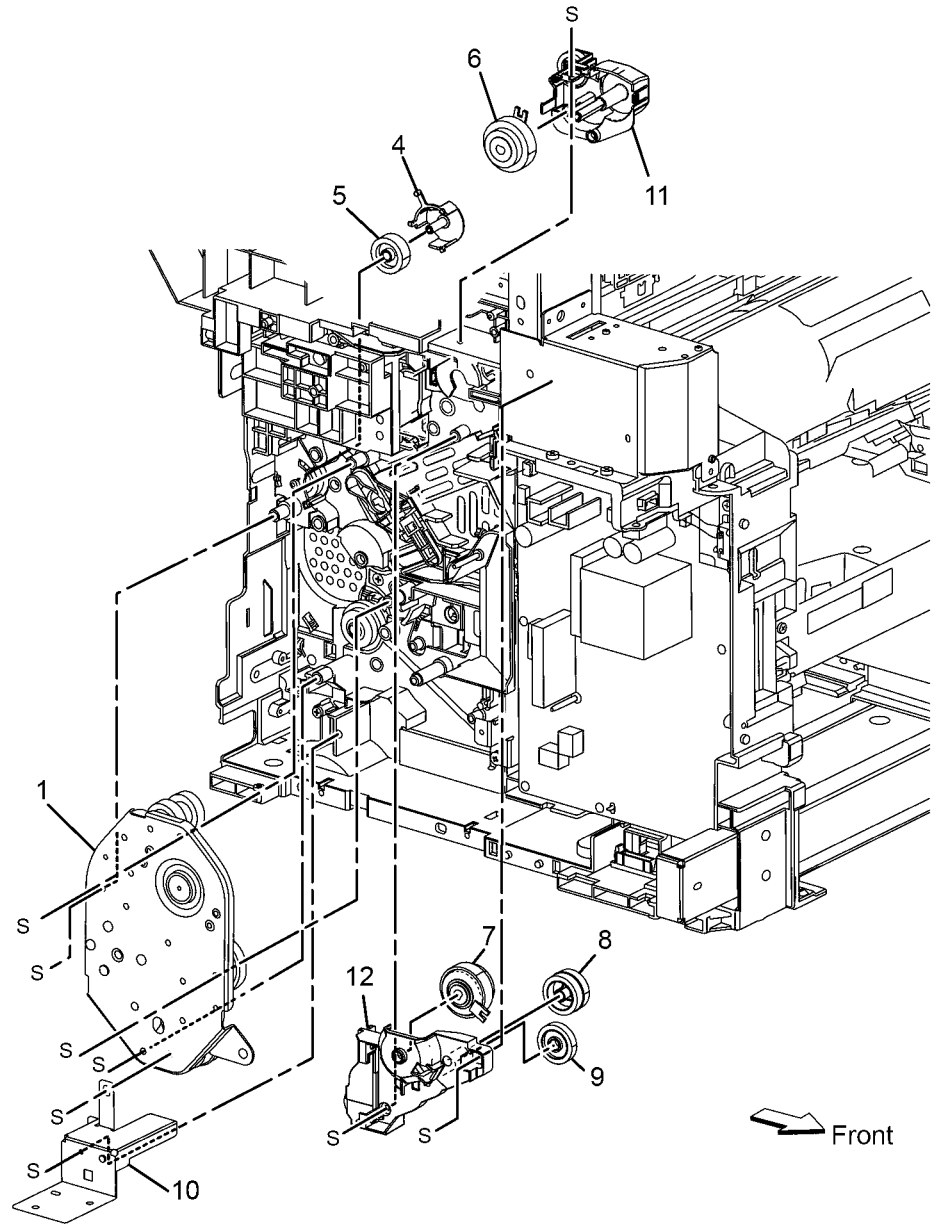

0503001A-BUR

PL 4.1 NOHAD & Links

Item	Part	Description
1	127K72250	Fan Assembly Main
2	—	Duct ESS
3	012E18133	Link Front Right
4	012E18143	Link Front Left
5	—	Link Shaft Right
6	—	Link Shaft Left
7	012E18172	Link Connector
8	—	Link Interlock CRU
9	—	Stopper Assembly Xero Right
10	—	Stopper Assembly Xero Left
11	—	Spring Interlock CRU
12	—	Foot (p/o item 99)
99	604K77650	Kit Foot Assy (3 pieces)

99 { 12 (3 pieces)

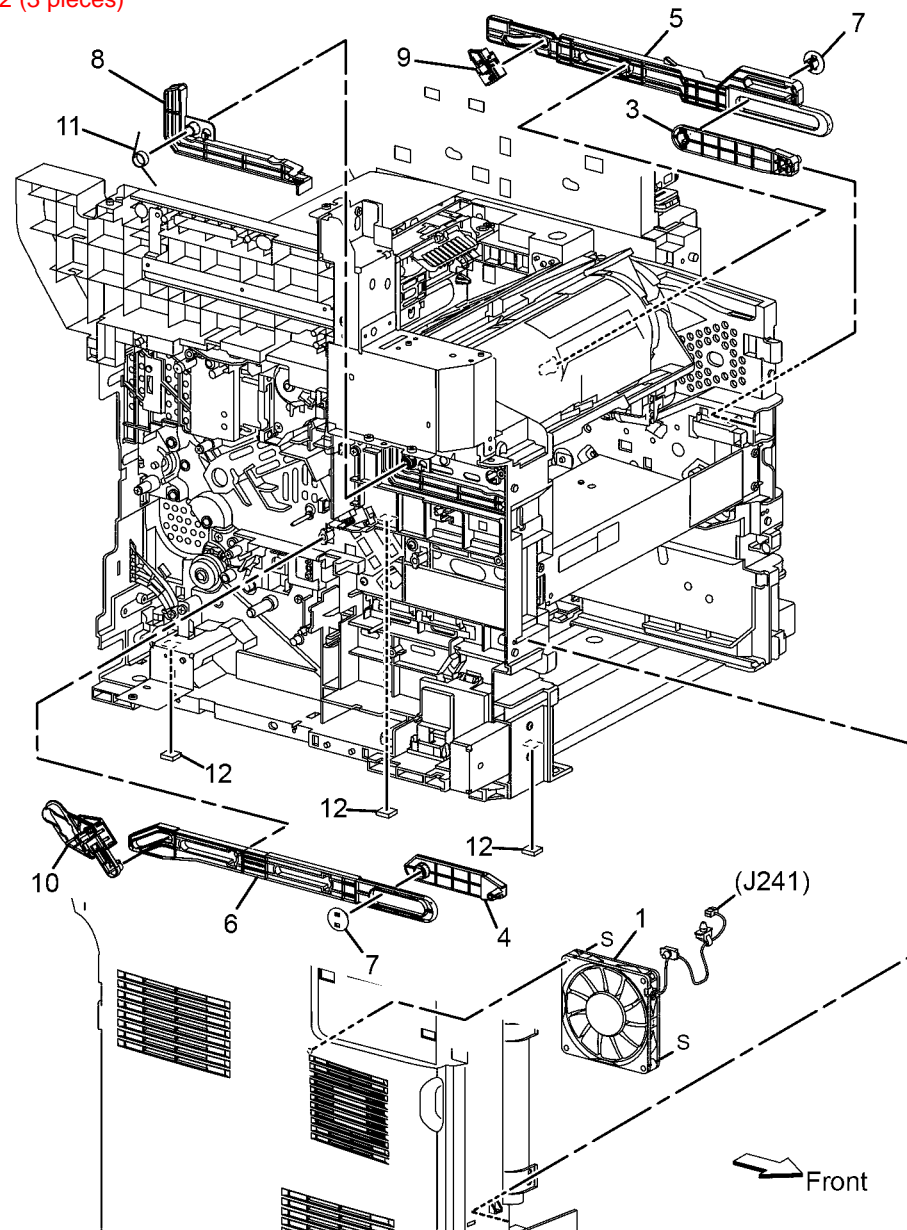

0504001A-BUR

PL 5.1 Dispenser

Item	Part	Description
1	604K77290	Kit CRUM Assy
2	-	Connector Assy CRUM (p/o item 1)
3	-	Housing CRUM (p/o item 1)
4	-	Spring CRUM (p/o item 1)
5	007K18413	Drive Assy Disp
6	-	Housing Disp Drive (p/o item 5)
7	-	Gear Idler Motor (p/o item 5)
8	-	Gear Output (p/o item 5)
9	127K52160	Motor Disp N
10	116K91040	Connector Assy, Xerographic
11	-	CRUM Assy

1 { 2, 3, 4, 11
5 { 6-8

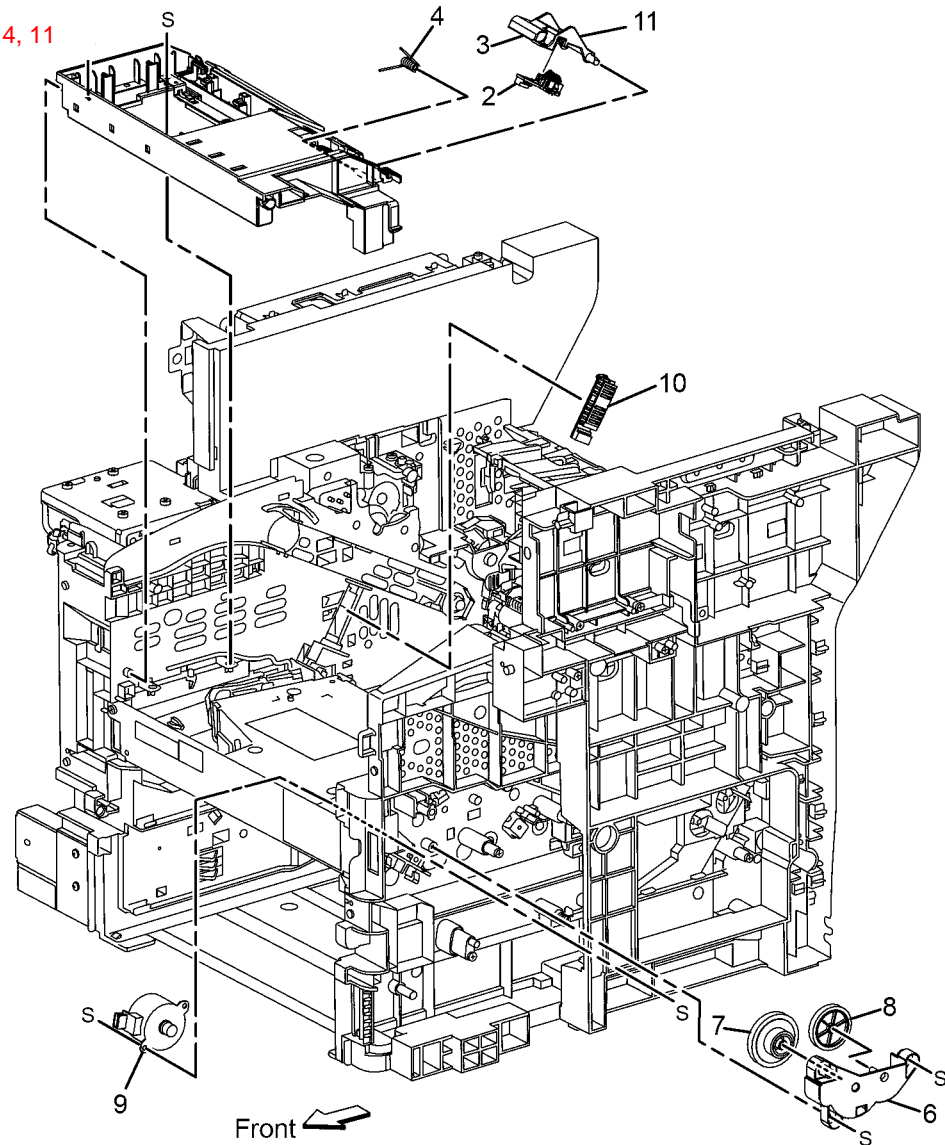

0505001A-BUR

PL 6.1 Transfer

Item	Part	Description
1	059K75560	Roll Assy Trans CRU (included in Fuser Maintenance Kit, shown on PL8.1)

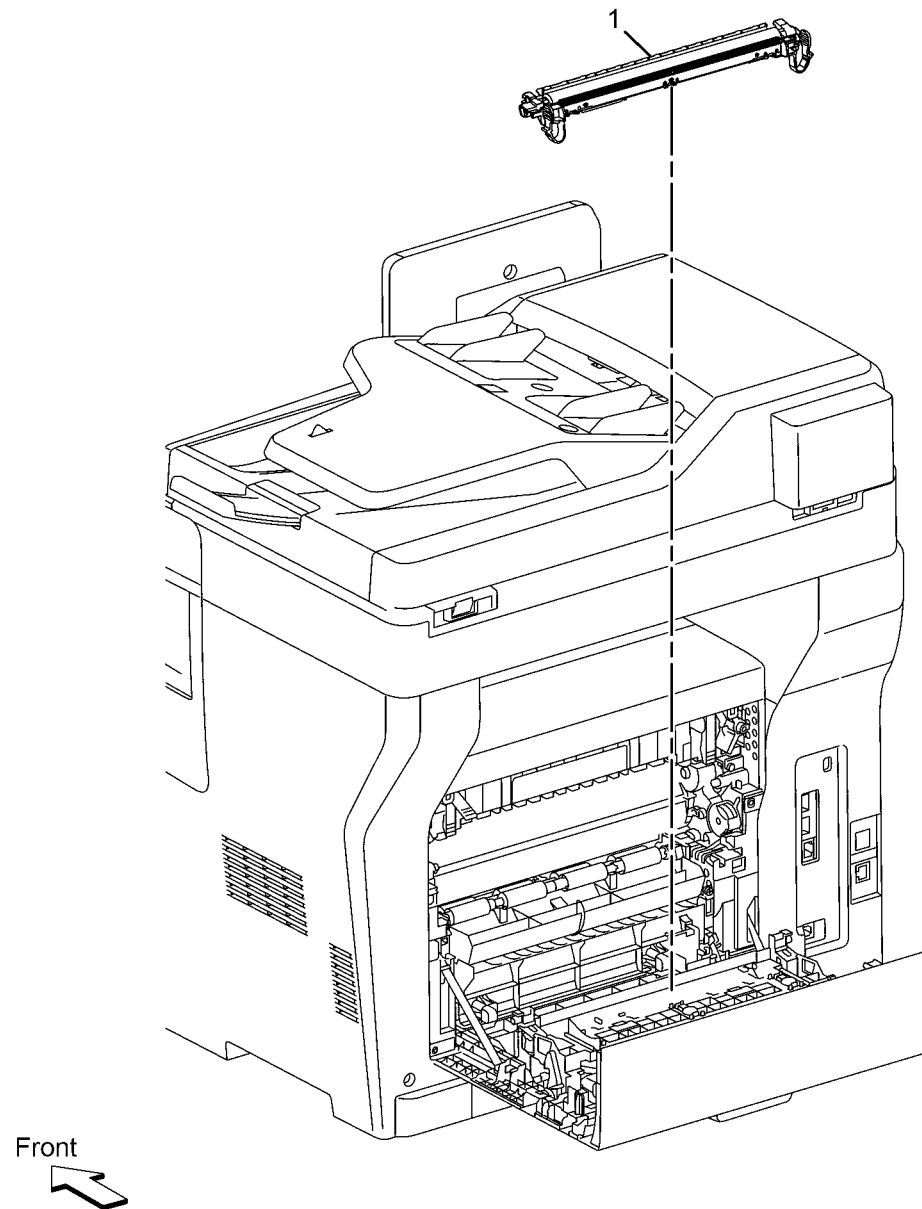

0506001A-BUR

PL 7.1 Fuser

Item	Part	Description
1	126K35561	Fusing Unit 220V
-	126K35551	Fusing Unit 110V (see Note 1)
	604K98010	Envelope Fuser, 110V

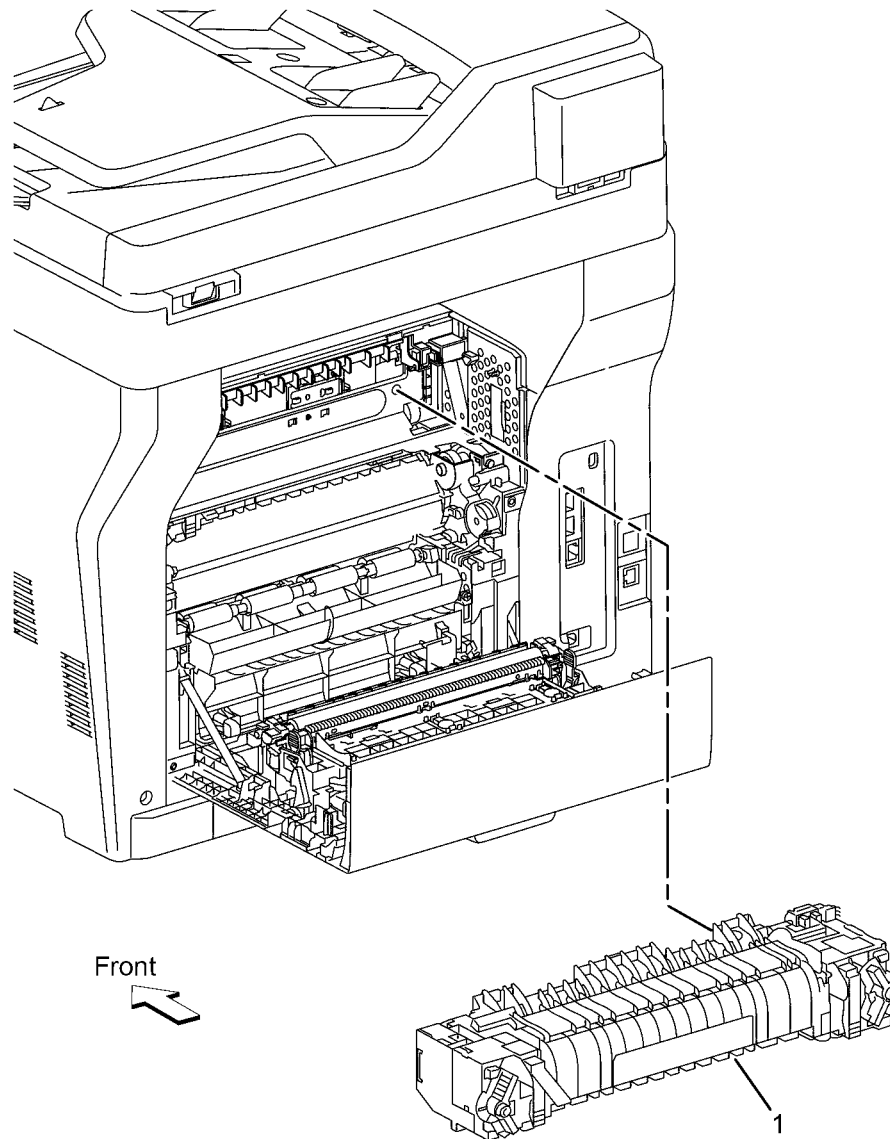

Note 1: Part is included in Fuser Maintenance Kit, shown on PL8.1

0507001A-BUR

PL 8.1 Xerographics

Item	Part	Description
1	113R00773	Xero Assy
2	106R02737	Kit PKG TN XC DMO 6K
-	106R02738	Kit PKG TN XC EU/US 14K
-	106R02740	Kit PKG TN XC EU/US 25K
-	106R02741	Kit PKG TN XC DMO 25K
-	106R02742	Kit PKG TN XC WW 25K Metered
-	106R02736	Kit PKG TN XC EU/US 6K
-	106R02739	Kit PKG TN XC DMO 14K
3	115R00084	Fuser Maintenance Kit (includes Fuser and Transfer Roller)

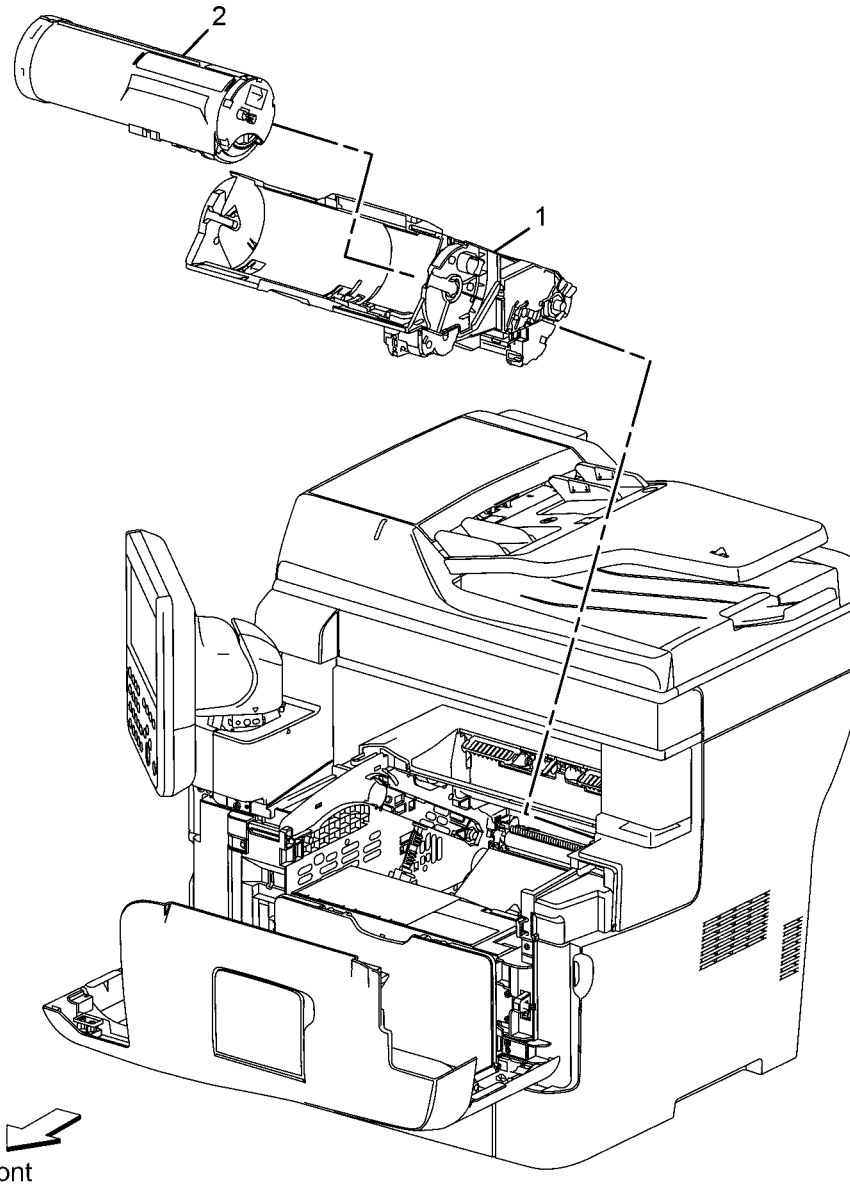

0508001A-BUR

PL 9.2 Tray 550

Item	Part	Description
1	050K72340	Cassette Assy 550
2	-	Plate Bottom CST X
3	604K78360	Holder Assy Retard CST
4	-	Roll Assy Feed (part of 3, and part of 98)
5	-	Clutch Friction RTD Z (part of 3)
6	-	Shaft Retard CST (part of 3)
7	-	Holder Retard CST (part of 3)
8	-	Guide Assy Side R 550
9	-	Guide Assy Side L 550
10	-	Gear Pinion
11	-	Cover BTM Lock 550
12	-	Back BTM Lock 550
13	-	Gear BTM Lock Pinion
14	-	Gear Lever BTM Lock
15	-	Lever BTM Lock
16	-	Gear 40 BTM Lock
17	-	Spring BTM Lock
18	-	Spring Lock PB
19	-	Actuator Lock PB L
20	-	Actuator Size
21	-	Spring BTM Up 550 A4
22	-	Holder Spring Retard MSI
23	-	Spring Retard CST
24	-	Rack Left Up PB 550
25	-	Housing Base 550
26	-	Lever EXT End 550
27	-	Guide End 550
28	-	Housing End 550
29	-	Plate Slot Size
30	-	Handle Tray 550
31	-	Pad PB
32	-	Label-INST D
33	-	LABEL-INST AD
34	-	LABEL-TRACEABILITY TRAY 550
35	-	--
36	-	HANDLE GD SD 550
37	-	--
38	-	Handle Guide End 550
39	-	Dust Cover
98	604K11192	Kit Roll Assy Feed (Item 4, 3 pieces)

1 { 2-36, 38
 3 { 4-7
 98 { Item 4, 3 pieces

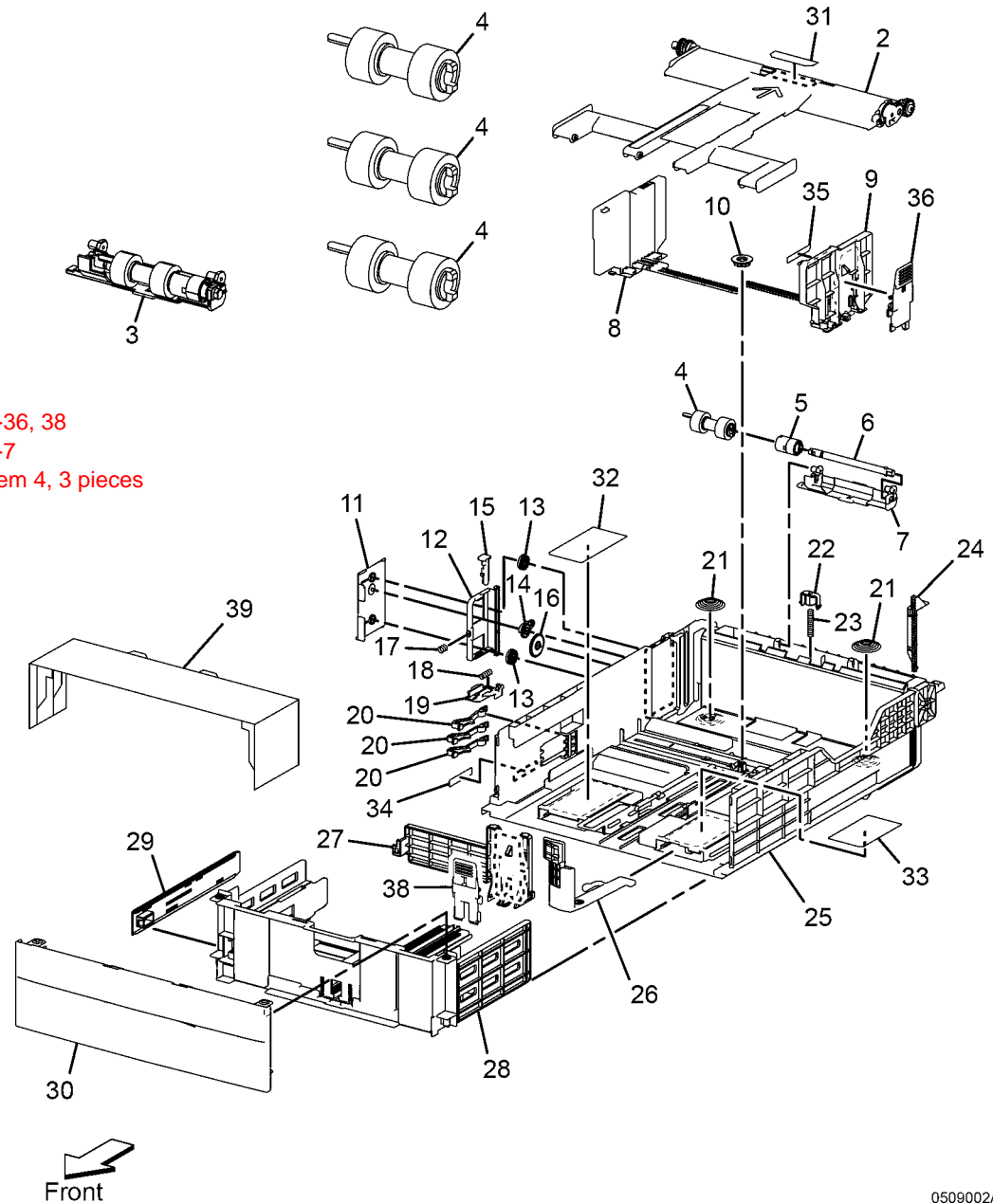

0509002A-BUR

PL 11.1 Option Feeder 550 (1/4)

Item	Part	Description
1	059K87520	Feeder Assy OPT 550 (w/o Item 15, tray)
2	-	Cover Side L OPT 550
3	-	--
4	-	--
5	960K76390	PWBA Assy OPT Tray
6	-	--
7	-	Drive Assy OPT 550 (with 10, 19)
8	005K83210	Clutch Assy OPT Feed
9	-	--
10	-	Gear OPT
11	-	Harness Assy Tray MOT
12	-	--
13	-	Cover Side R OPT 550
14	-	Foot
15	050K72340	Tray Assy 550 (REF: PL 11.3)
16	-	Cover-lip Top OPT
17	-	Cover Rear OPT 550
18	-	Harness Assy FDR Drawer 1
19	-	Motor-assy Option
20	059K86170	Feeder Assy OPT 550 (REF: PL 11.2)
21	-	--
22	-	--
23	-	--
24	-	--
25	-	--
26	-	Screw Lock
27	803E10840	STOPPER CST
28	-	--
29	-	--
30	-	Spring Cover Rear
31	-	Harness Assy FDR Drawer 2
32	-	--
33	-	Harness Assy C2 Turn
34	-	Bracket Rocate Pin 550
35	-	Cover Rear Under OPT 550
36	-	Optional Feeder Drive Motor
37	110K16610	Size Switch Assembly

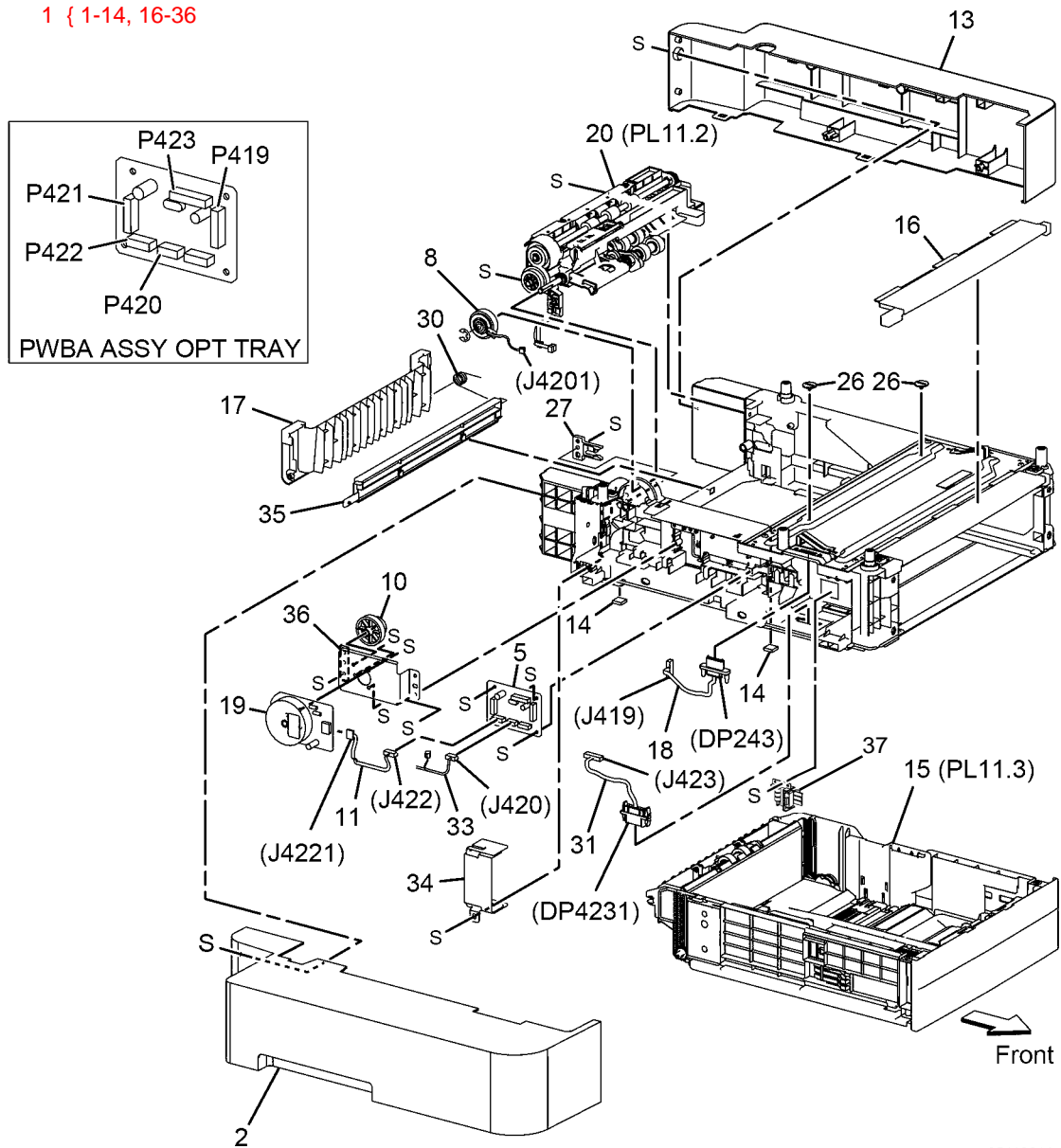

0511001A-BUR

PL 11.2 Option Feeder 550 (2/4)

Item	Part	Description
1	-	Cover Sensor No Paper
2	930W00123	No Paper Sensor
3	-	Harness Assy OPT No paper
4	-	Chute-upper OPT 550
5	-	Bearing Nudger
6	-	Support Assy Nudger
7	-	Clutch One way Feed
8	-	Gear Feed
9	-	--
10	-	Gear Idler Nudger
11	120E33253	Actuator No Paper
12	-	Shaft Nudger
13	-	Roll Assy Feed (see PL 11.3.98)
14	-	Gear Nudger
15	-	Chute-lower OPT 550
16	-	Shaft Assy-feed 550
17	-	--
18	-	--
19	-	Chute Assy Pinch 550 (see PL 11.4)
20	121K48670	Clutch Assy Registration
21	059K71770	Roll Assy Take Away
22	-	Plate Earth T A
23	-	Bracket Spring Nudger
24	-	Cover Harness SNS
25	-	Shaft Gear
26	-	Gear OPT Feeder 550
27	-	Spring Nudger OPT

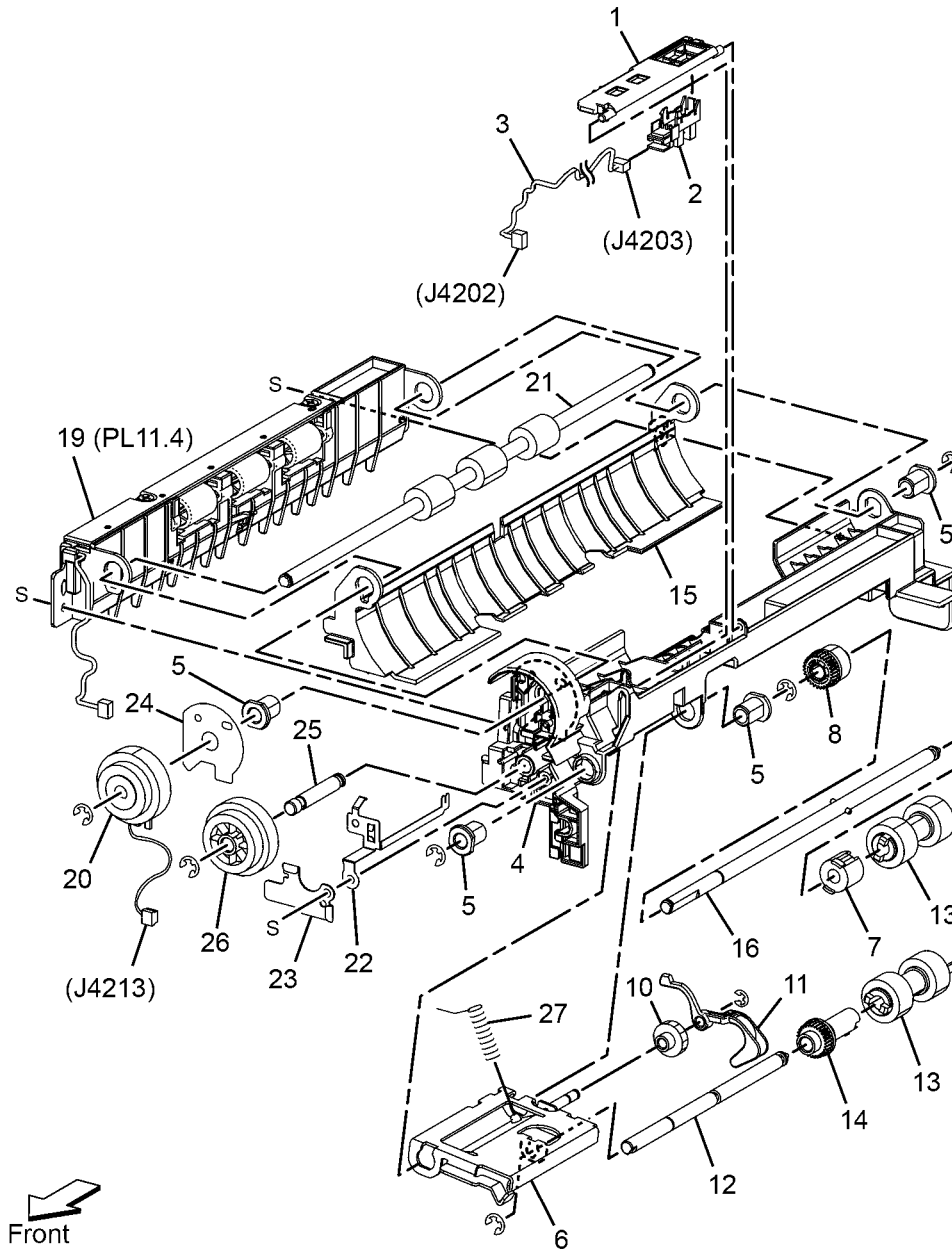

0511002A-BUR

PL 11.3 Option Feeder 550 (3/4)

Item	Part	Description
1	050K72340	Cassette Assy 550
2	-	Plate Bottom CST X
3	604K78360	Holder Assy Retard CST
4	-	Roll Assy Feed (part of 3, and part of 98)
5	-	Clutch Friction RTD Z (part of 3)
6	-	Shaft Retard CST (part of 3)
7	-	Holder Retard CST (part of 3)
8	-	Guide Assy Side R 550
9	-	Guide Assy Side L 550
10	-	Gear Pinion
11	-	Cover BTM Lock 550
12	-	Back BTM Lock 550
13	-	Gear BTM Lock Pinion
14	-	Gear Lever BTM Lock
15	-	Lever BTM Lock
16	-	Gear 40 BTM Lock
17	-	Spring BTM Lock
18	-	Spring Lock PB
19	-	Actuator Lock PB L
20	-	Actuator Size
21	-	Spring BTM Up 550 A4
22	-	Holder Spring Retard MSI
23	-	Spring Retard CST
24	-	Rack Left Up PB 550
25	-	Housing Base 550
26	-	Lever EXT End 550
27	-	Guide End 550
28	-	Housing End 550
29	-	Plate Slot Size
30	-	Handle Tray 550
31	-	Pad PB
32	-	Label-INST D
33	-	Label-INST AD
34	-	Label-Traceability Tray 550
35	-	--
36	-	Handle GD SD 550
37	-	--
38	-	Handle Guide End 550
39	-	Dust Cover
98	604K11192	Kit Roll Assy Feed (Item 4, 3 pieces)

1 { 2-38
 3 { 4-7
 98 { Item 4, 3 pieces

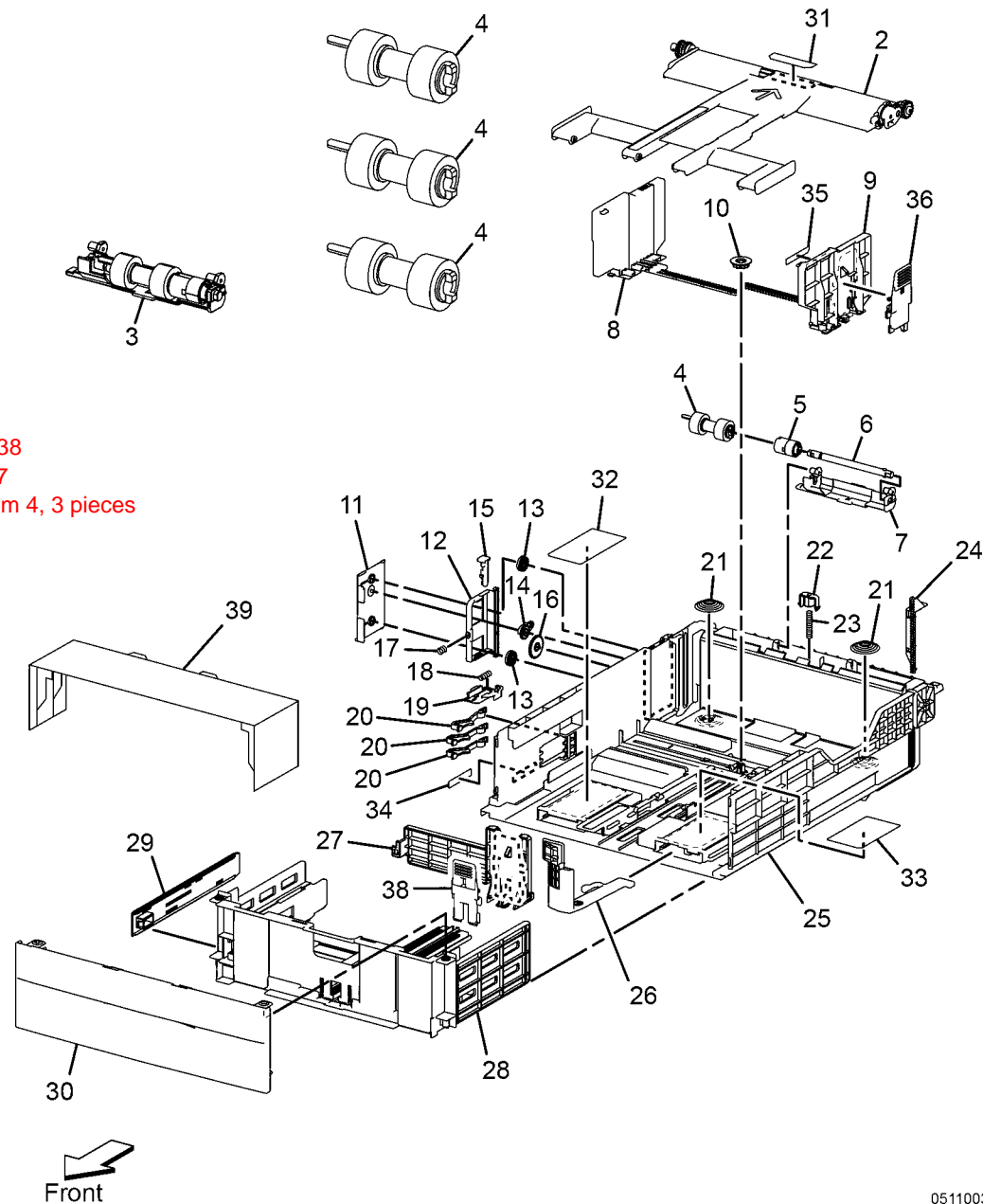

0511003A-BUR

PL 11.4 Option Feeder 550 (4/4)

Item	Part	Description
1	-	Chute Pinch 550
2	-	Roll Pinch TA OP
3	-	Cover Chute
4	930W00123	Sensor Photo (Path Sensor)
5	-	Actuator PRE REGI
6	-	Spring Sensor PRE REGI
7	-	Harness Assy OPT REG
8	-	Spring Pinch TA OP

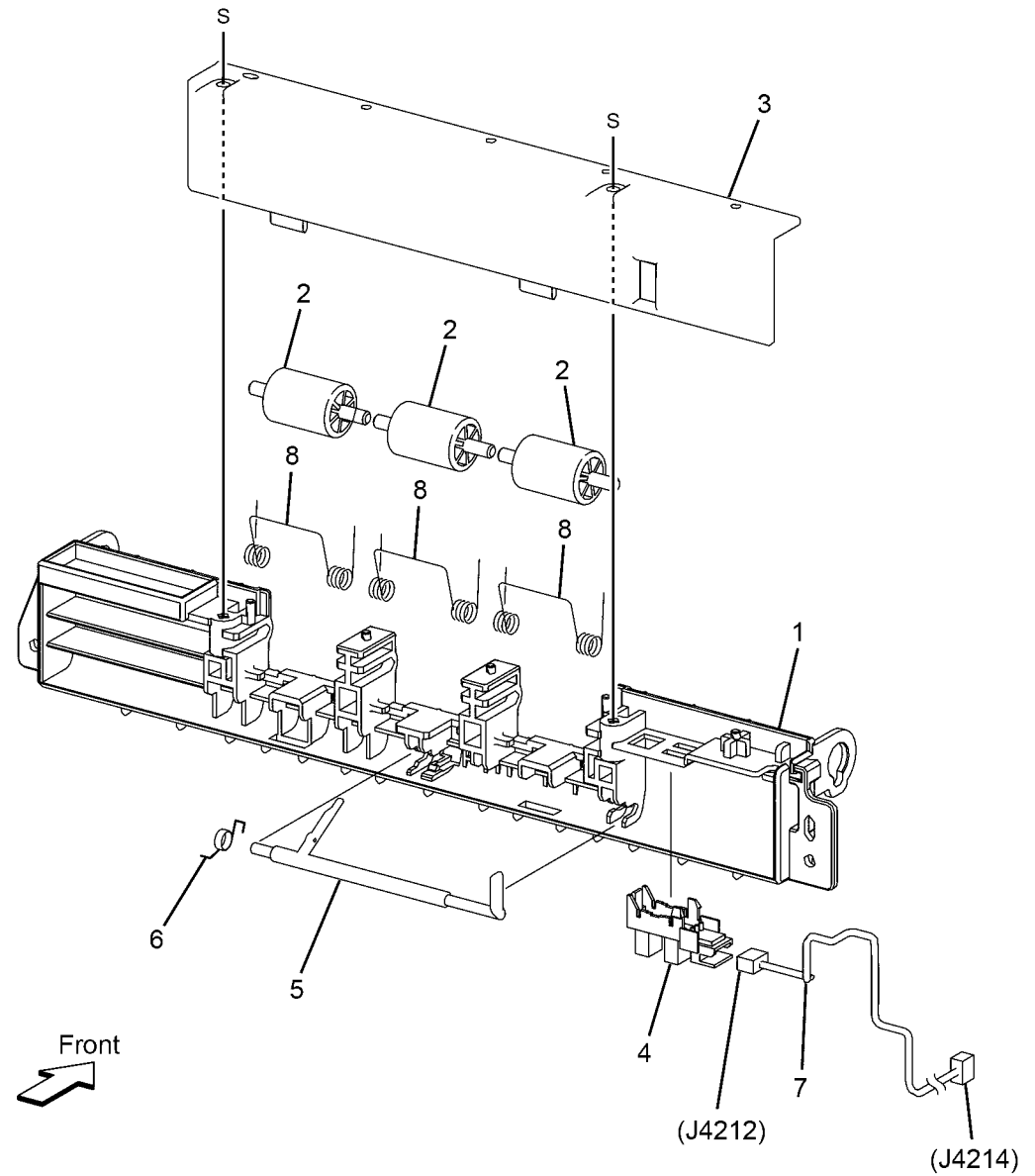

0511004A-BUR

PL 13.1 MSI (1/2)

Item	Part	Description
1	801K57914	Frame Assy Top MSI
2	-	Lock MSI IN (p/o item 1)
3	-	Frame Top MSI (p/o item 1)
4	-	Actuator No Paper MSI (p/o item 1)
5	121E23570	Solenoid Feed MSI
6	-	Gear Segment MSI 1
7	-	Gear Segment MSI 2
8	-	Bearing Feed MSI
9	-	Arm Lifter MSI
10	-	Stopper Lifter MSI
11	-	Spring Feed MSI
12	-	Gear Feed MSI
13	-	Lever Lifter MSI
14	-	Spring NF MSI
15	059K78790	Holder Assy Pick Up
16	-	Holder Pick Up
17	-	Gear Idler Feeder
18	-	Roll Assy Feed
19	-	Roll Rubber
20	-	Core Roll
21	-	Shaft Feed MSI
22	-	Bearing Feed MSI
23	-	Flange Pick Up

1{ 2-4

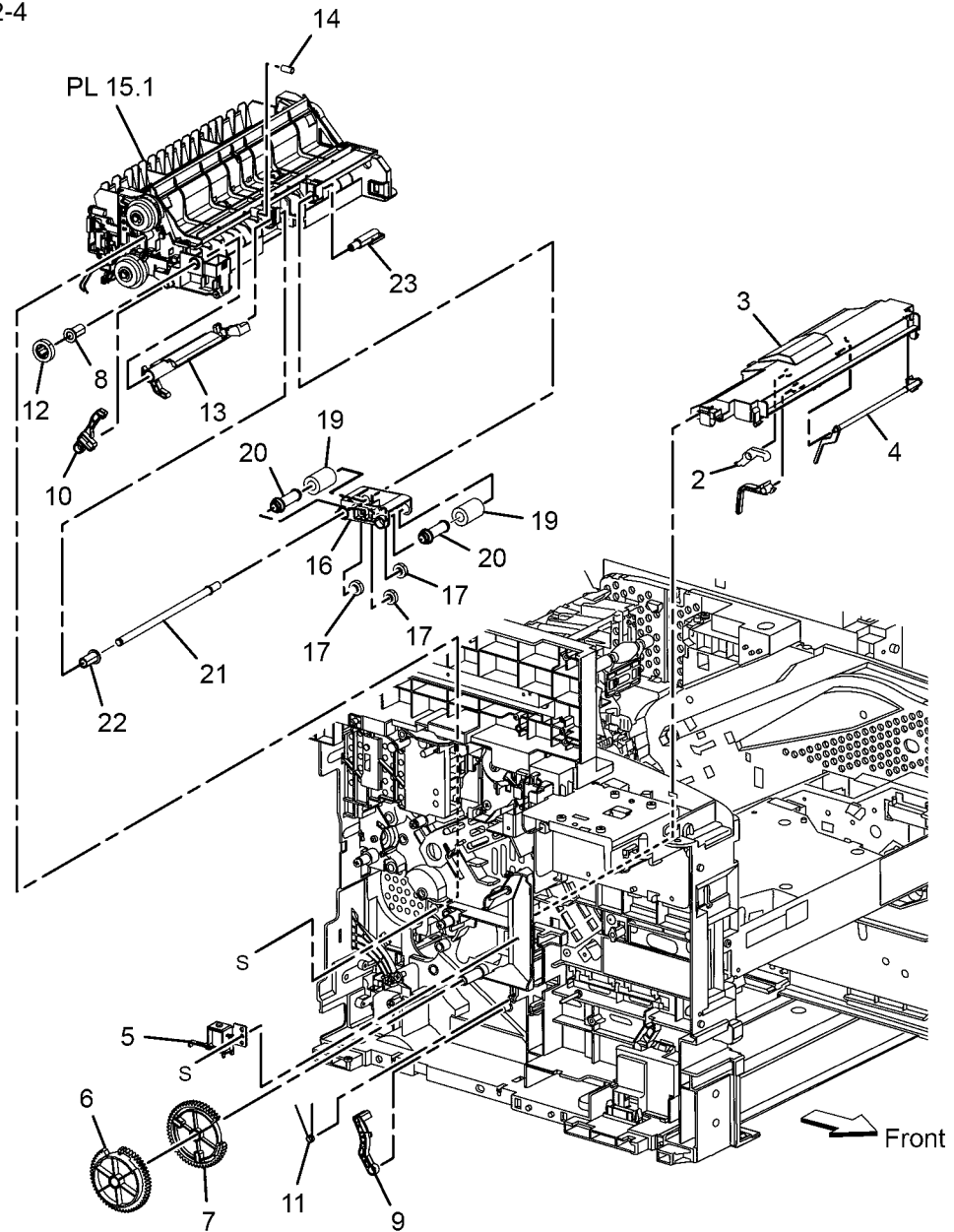

0513001A-BUR

PL 13.2 MSI (2/2)

Item	Part	Description
1	–	Tray Base MSI
2	–	Guide End MSI
3	–	Cover MSI
4	–	Holder-End MSII
5	–	Pad MSI
6	–	Guide-Side MSI L
7	–	Guide-Side MSI R
8	–	--
9	–	--
10	–	Spring-Retard Roll (part of 98)
11	–	Spring-Stopper Sheet 150
12	–	Lock-Sheet 150
13	–	Guide-Retard MSI Mylar
14	–	Stopper-Sheet 150
15	–	Holder-Retard Roll (part of 98)
16	–	Roll Assy-Retard Roll (part of 98)
17	–	Clutch Assy Friction (part of 98)
18	–	Spring-MSI Paper Stopper Mid
19	–	Rack Guide Side
20	–	Gear Pinion
96	–	--
98	604K78370	Kit Retard Roll MSI Assy (p/o Item 99)
99	050K72540	Tray Assy MSI (ACO)

98 { 10, 15-17
99 { 1-20

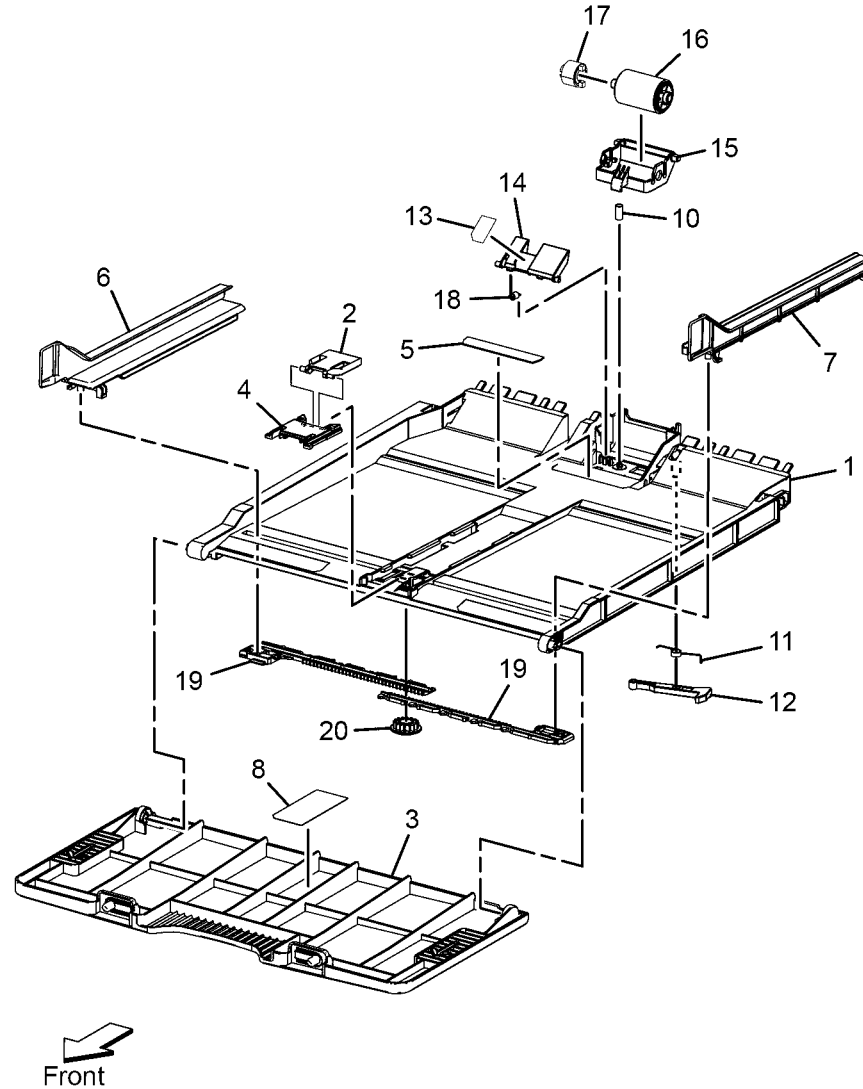

0513002A-BUR

PL 14.1 Duplex Chute

Item	Part	Description
1	-	Bearing DUP (p/o Item 12)
2	059K74750	Roll Assy DUP (p/o Item 12)
3	-	Spring Earth DTS (p/o Item 12)
4	-	Gear DUP (p/o Item 12)
5	-	Roll Pinch DUP (p/o Item 12)
6	-	Spring Pinch DUP (p/o Item 12)
7	-	Chute DUP IN (p/o Item 12)
8	-	Chute TRANS (p/o Item 12)
9	-	--
10	-	--
11	-	--
12	054K48100	Chute Assy-DUP
13	-	Cap-Spring BTR (p/o Item 12)
14	-	Spring-BTR (p/o Item 12)

12 { 1-8, 13, 14

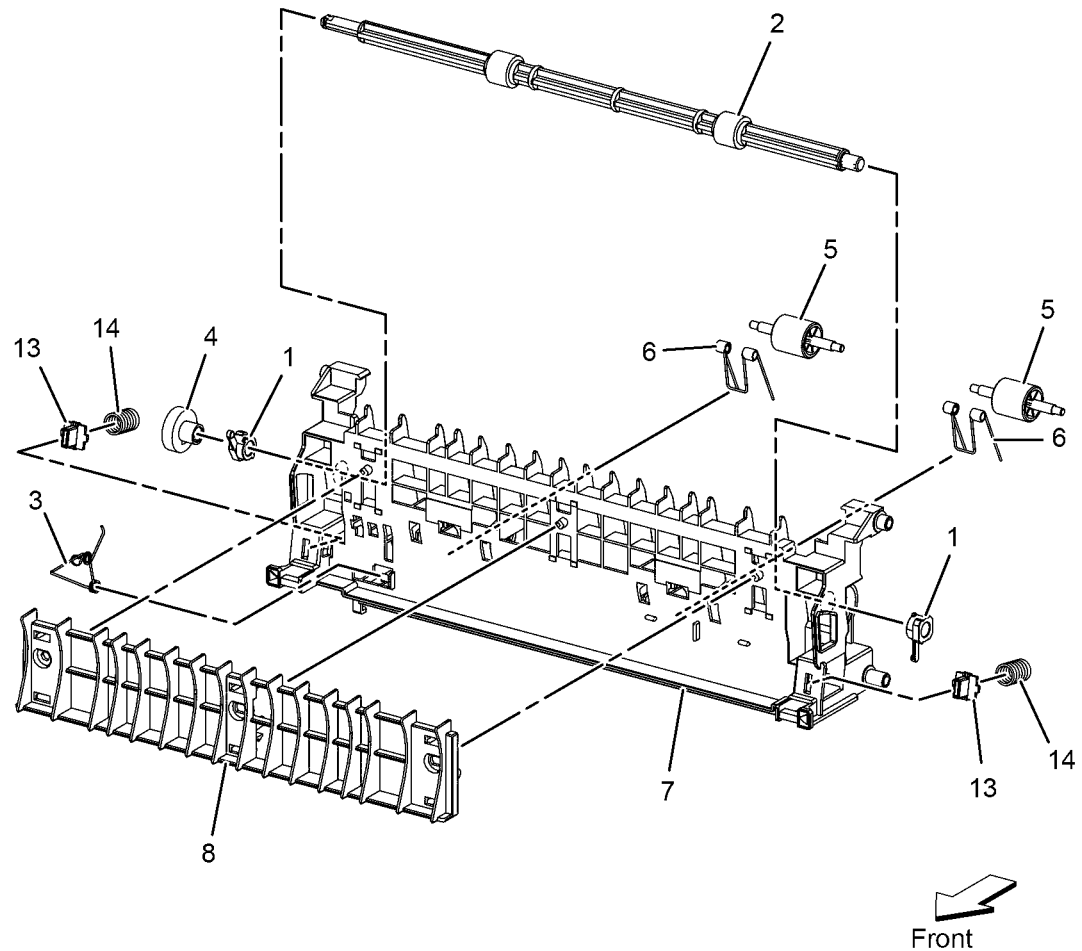

0514001A-BUR

PL 15.1 Registration (1/3)

Item	Part	Description
1	604K85750	Kit SW Assy I/L Rear
2	-	Chute DUP Lower (p/o Item 1)
3	-	Spring WC IL (p/o Item 1)
4	-	Rear Door Intlk Switch Assy. (p/o Item 1)
5	-	Spring Interlock
6	059K79334	Transport Assy-Registration FDR (PL 15.2)
7	-	Lock Tray
8	-	Plate Earth REGI OUT ZA
9	-	Holder-Connector Rear Fan
10	-	--
11	803E13351	Stopper CST ZA S3
12	-	Gear (not spared)

1 {2-4

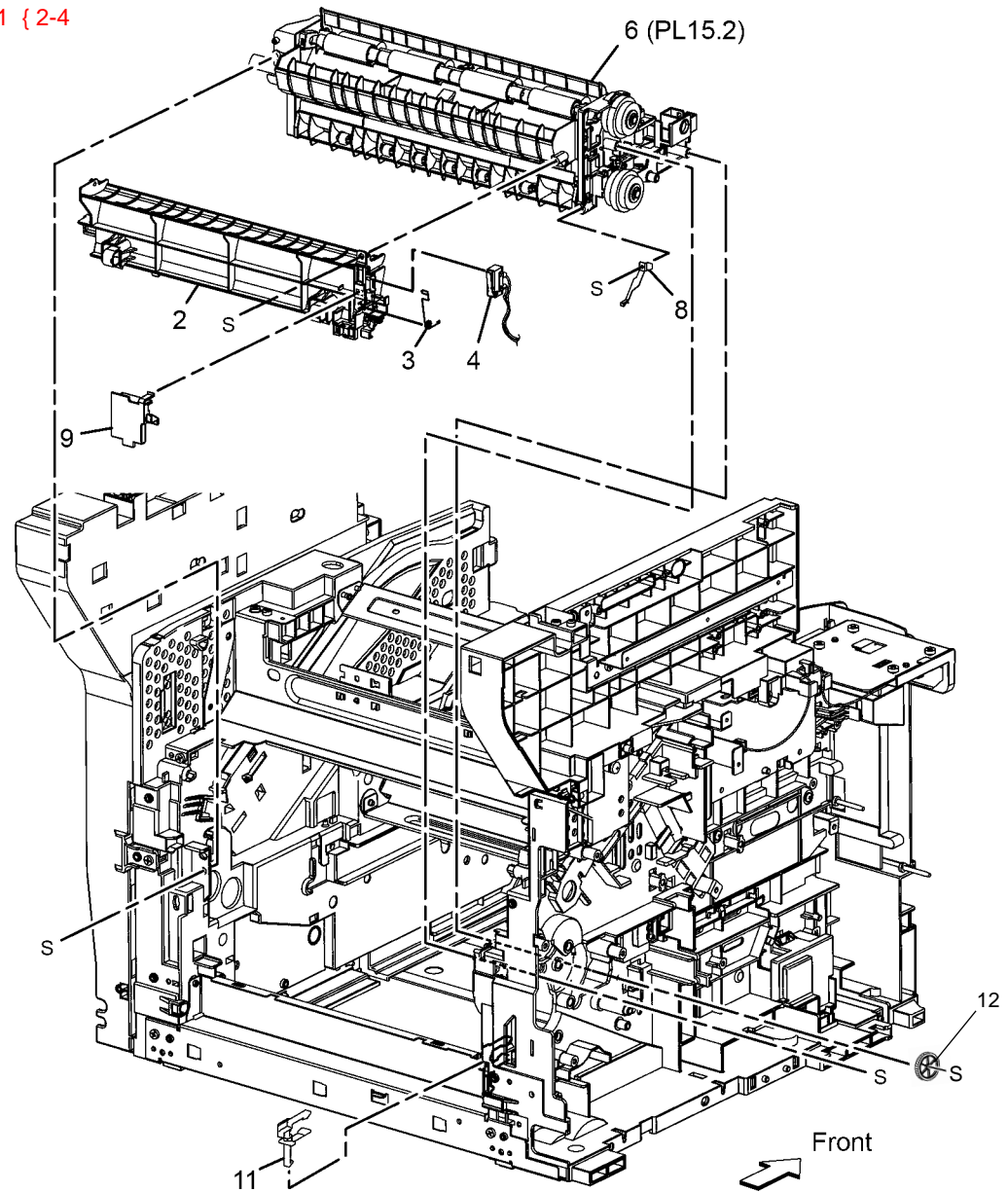

0515001A-BUR

PL 15.2 Registration (2/3) (Complete Registration Assy is on PL 15.1.6)

Item	Part	Description
1	—	Chute REGI IN
2	—	Roll Support 2
3	—	Spring REGI
4	121K51870	REGI. Clutch
5	—	Bearing REGI Earth ZA
6	059K74580	Roll Assy Rubber ZA
7	—	Bearing REGI R
8	—	Roll Assy REGI Pinch
9	—	Chute REGI OUT
10	—	Chute Feed Lower MID (p/o PL 15.1.6)
11	—	--
12	—	Chute REGI
13	—	--
14	055E60433	Shutter Sensor REGI
15	—	--
16	121K51880	CST Feed Clutch
17	—	--
18	—	Actuator REGI MSI
19	—	Spring Actuator REGI ZA
20	—	Actuator REGI
21	—	Actuator No Paper Tray
32	—	Guide Chute
33	—	Roll Support 2
34	—	Bracket Nudger AD (LOW)
35	—	Actuator No Paper Tray M B
36	—	Shaft REGI Pinch
37	—	Roll REGI Pinch
38	—	Bearing REGI CTR
39	—	Roll Support 2
40	—	Bracket Nudger D
99	—	Kit Feeder Assy (see PL 15.3)

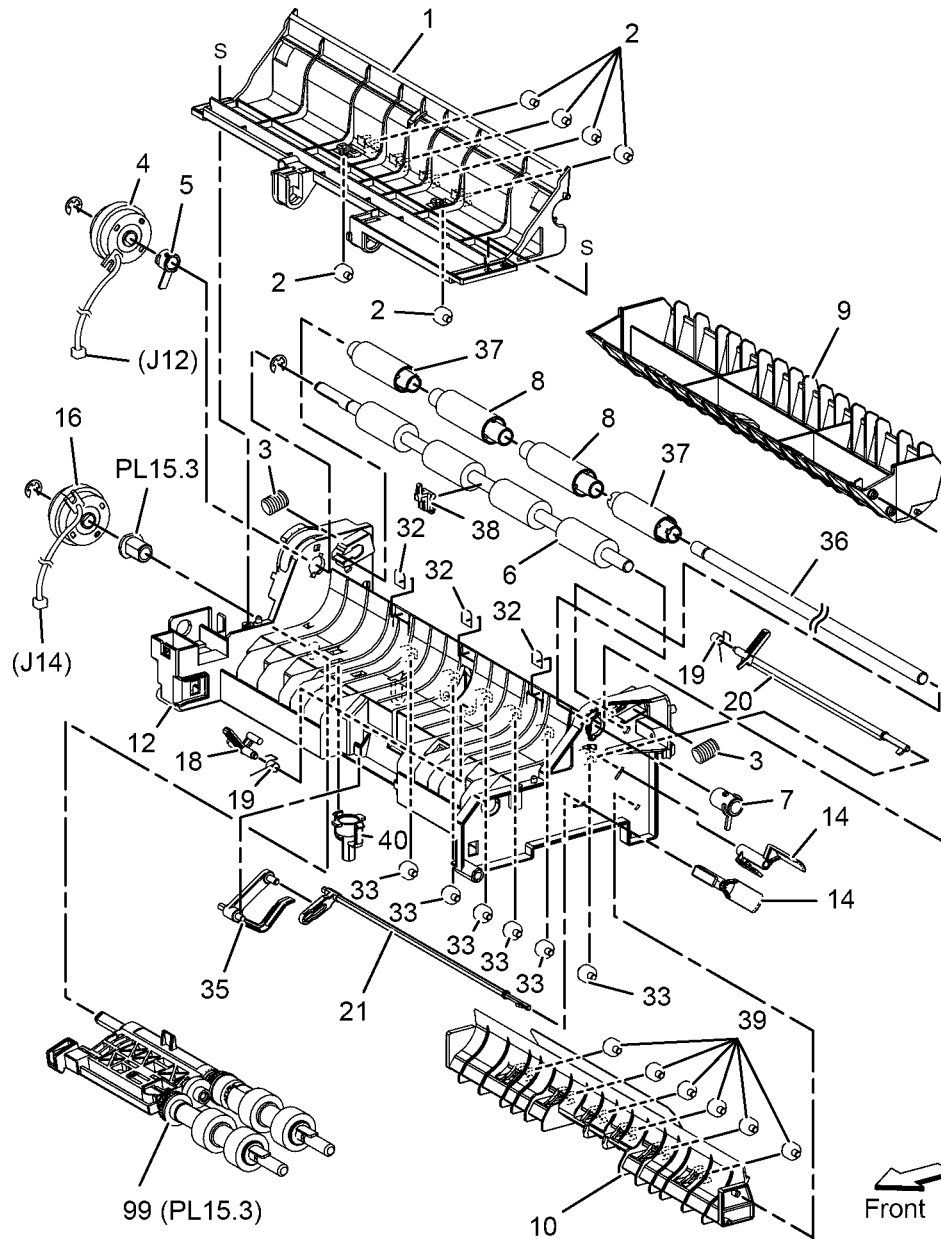

0515002A-BUR

PL 15.3 Registration (3/3)

Item	Part	Description
1	-	Bearing Nudger
2	-	Feeder Assy
3	-	Gear Feed
4	-	Clutch One Way Feed
5	604K11192	Feed Roll Kit (contains 3 rollers)
6	-	Shaft Assy Feed
7	-	Plate Nudger
8	-	Gear Idler Nudger
9	-	Gear Nudger T1
10	-	Shaft Nudger ZA
11	-	Bearing Nudger D

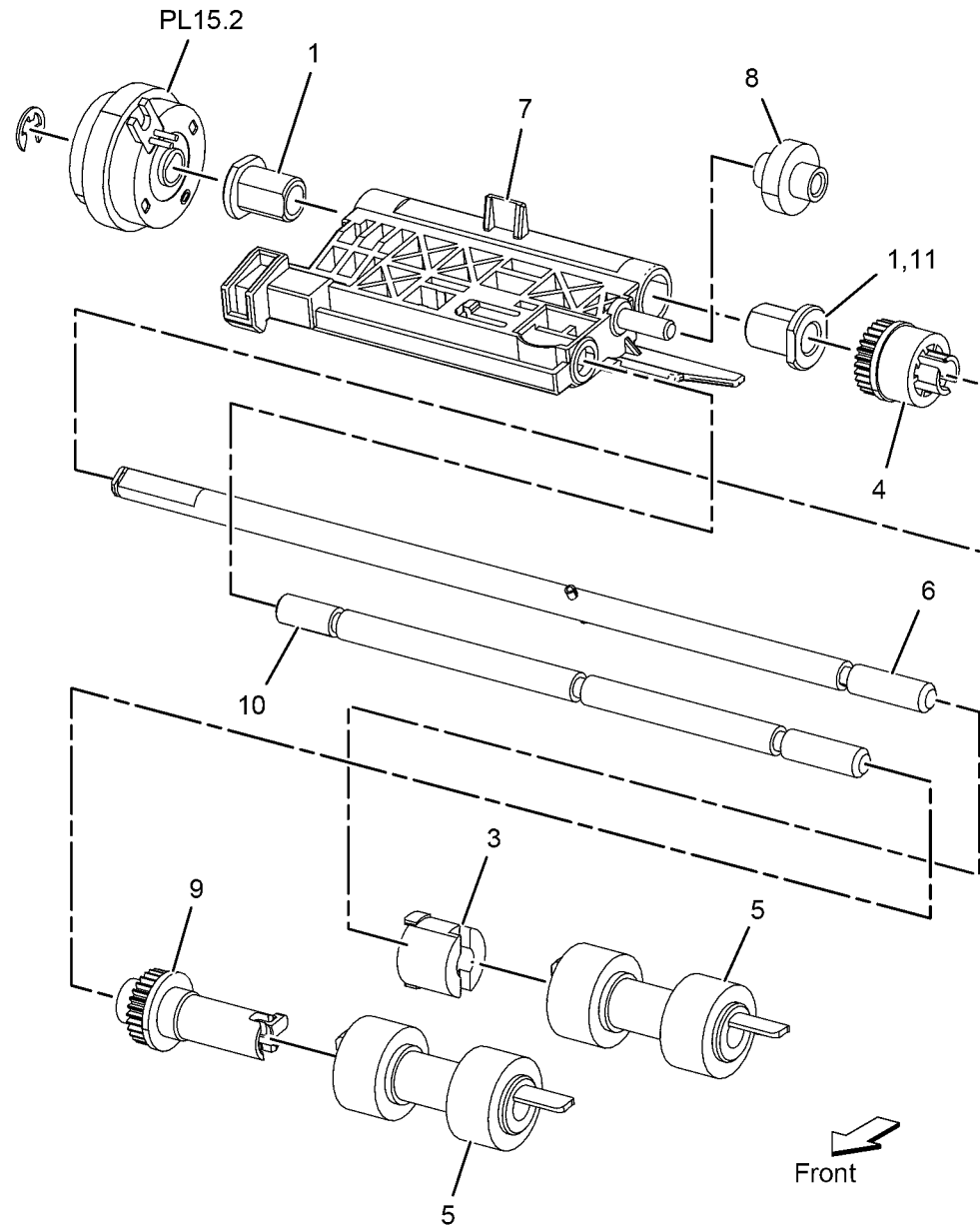

0515003A-BUR

PL 17.1 Exit

Item	Part	Description
1	930W00123	Exit Sensor
2	-	Gear Exit
3	-	Spring Earth Sensor
4	-	Bearing Exit
5	059K79430	Roll Assy Exit
6	604K77510	Kit Pinch Assy L
7	604K77520	Kit Pinch Assy R
8	-	Actuator Full Stack
9	930W00123	Full Stack Sensor
99	054K48380	Chute Assy Exit

99 { 1-5, 8, 9

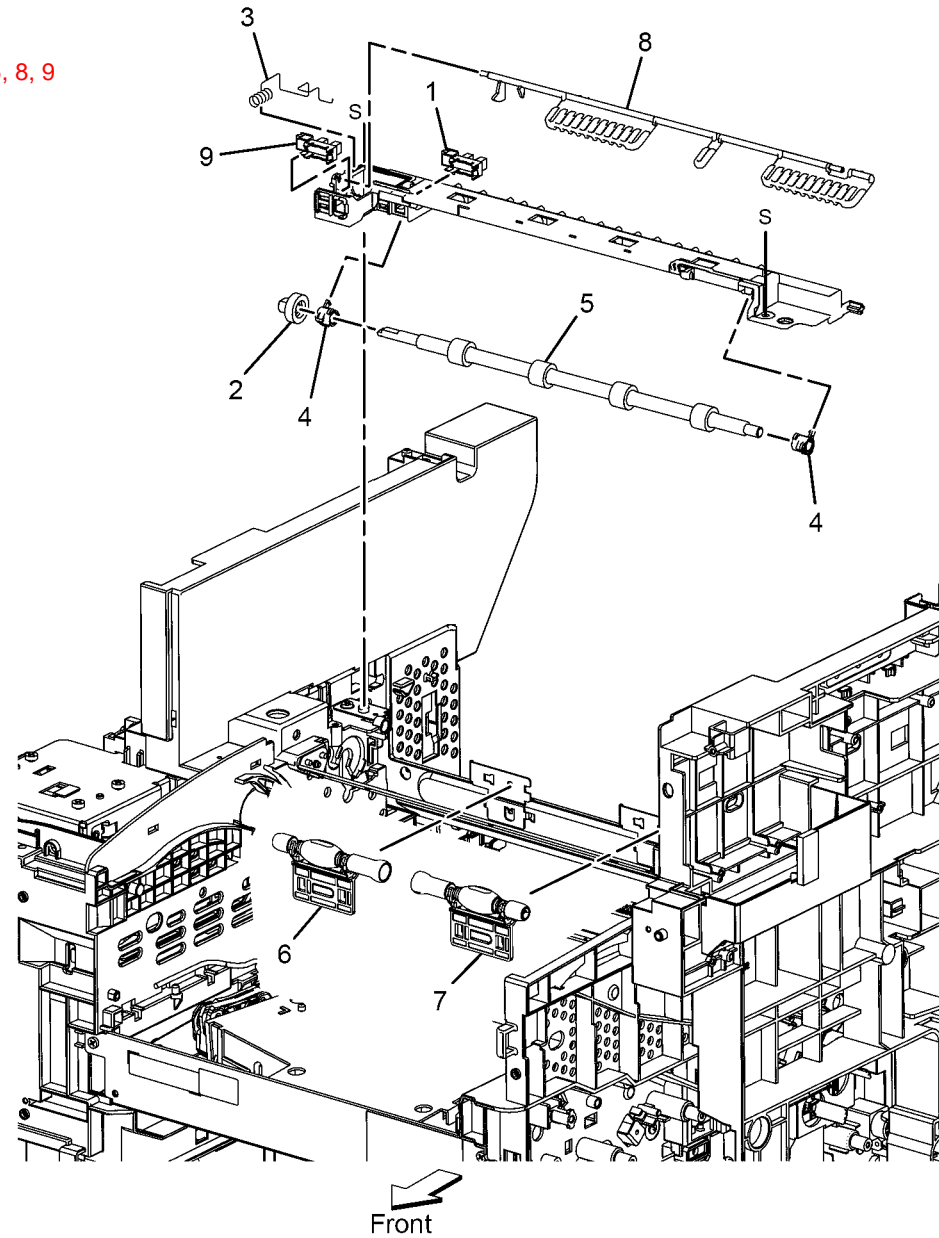

0517001A-BUR

PL 18.1 Electrical (1/4)

Item	Part	Description
1	-	Plate Window ESS IIT Control Board
2	-	Box ESS IIT Control Board
3	604K90920	ESS Board Kit (REP18.1.98)
4	960Kxxxx	IIT Control Board (see Note 2) (REP 18.1.4)
5	-	Bracket HDD
6	-	Chassis HDD
7	084K42805	Fax Board
8	-	Cable Fax
9	-	Bracket Fax
10	110K16610	SW Assy Size 550
11	-	CVR Sensor Size
12	105K32540	LVPS 220v
-	105K31910	LVPS 110v
13	-	Plate LVPS
14	952K17171	Side USB Assy
15	-	Guide Harness Fusing
16	-	SW Assy I/L
17	-	Bracket I/L
18	133K27490	RAM Memory
19	604K90940	SD Card (REP 18.1.96)
20	604K90931	HDD (REP 18.1.97)
21	-	Plate Assy ESS IIT-MCU

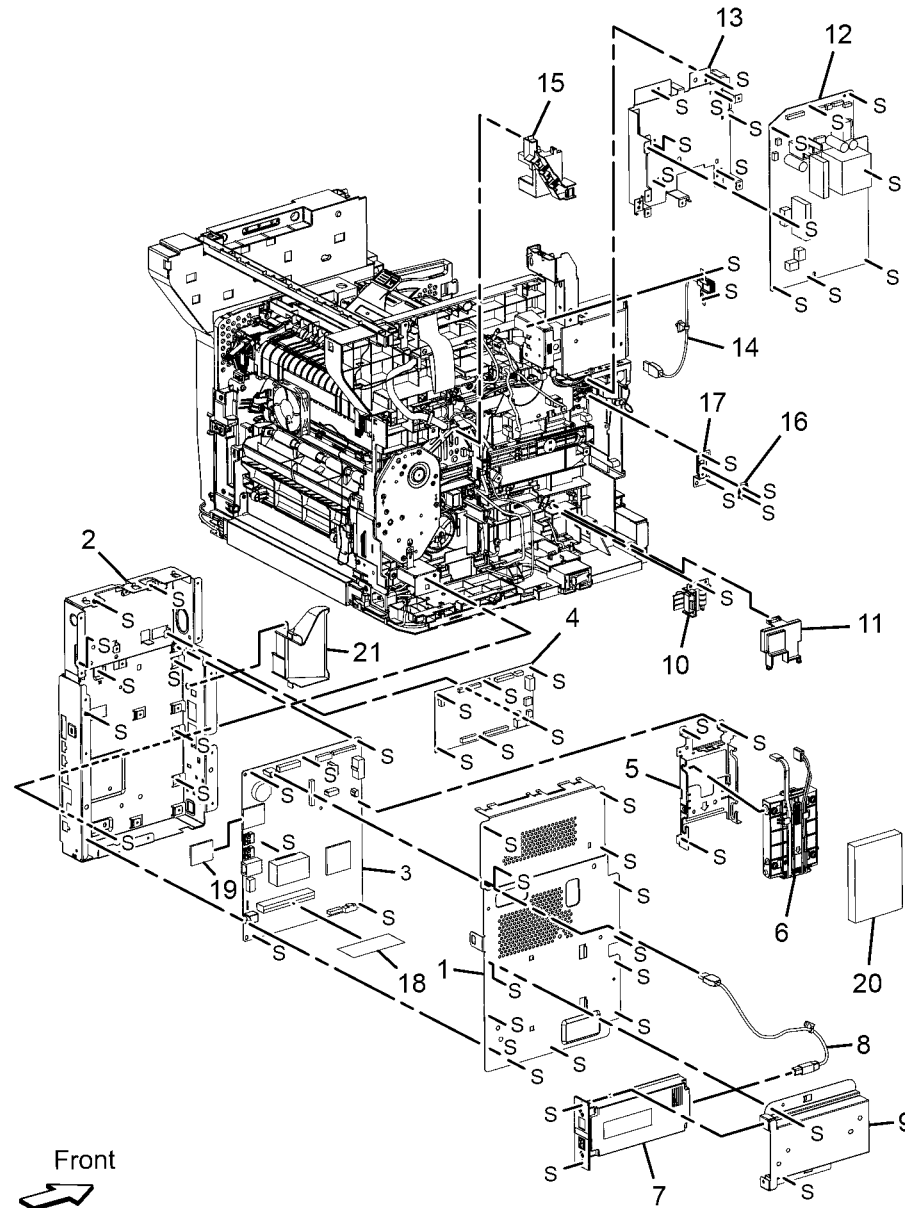

Note 1: If the Wireless Print Kit is defective, Sales will need to order a replacement. 497K11500

Note 2: Before replacing the IIT Control board, see the critical information in Eureka Tip # [1368189](#).

0518001A-BUR

PL 18.2 Electrical (2/4)

Item	Part	Description
1	-	CVR MCU
2	960K74850	MCU Board
3	-	Bracket MCU
4	-	Housing MCU
5	105K30954	HVPS
6	-	Stapler Assy (p/o item 99)
7	-	Stapler Cartridge (p/o item 99)
8	-	Housing Stapler
9	105K31942	PWBA Stapler LVPS 220v
-	105K31930	PWBA Stapler LVPS 110v
10	-	Plate Sub LVPS
99	604K90550	Kit Stapler Assy

99 { 6, 7

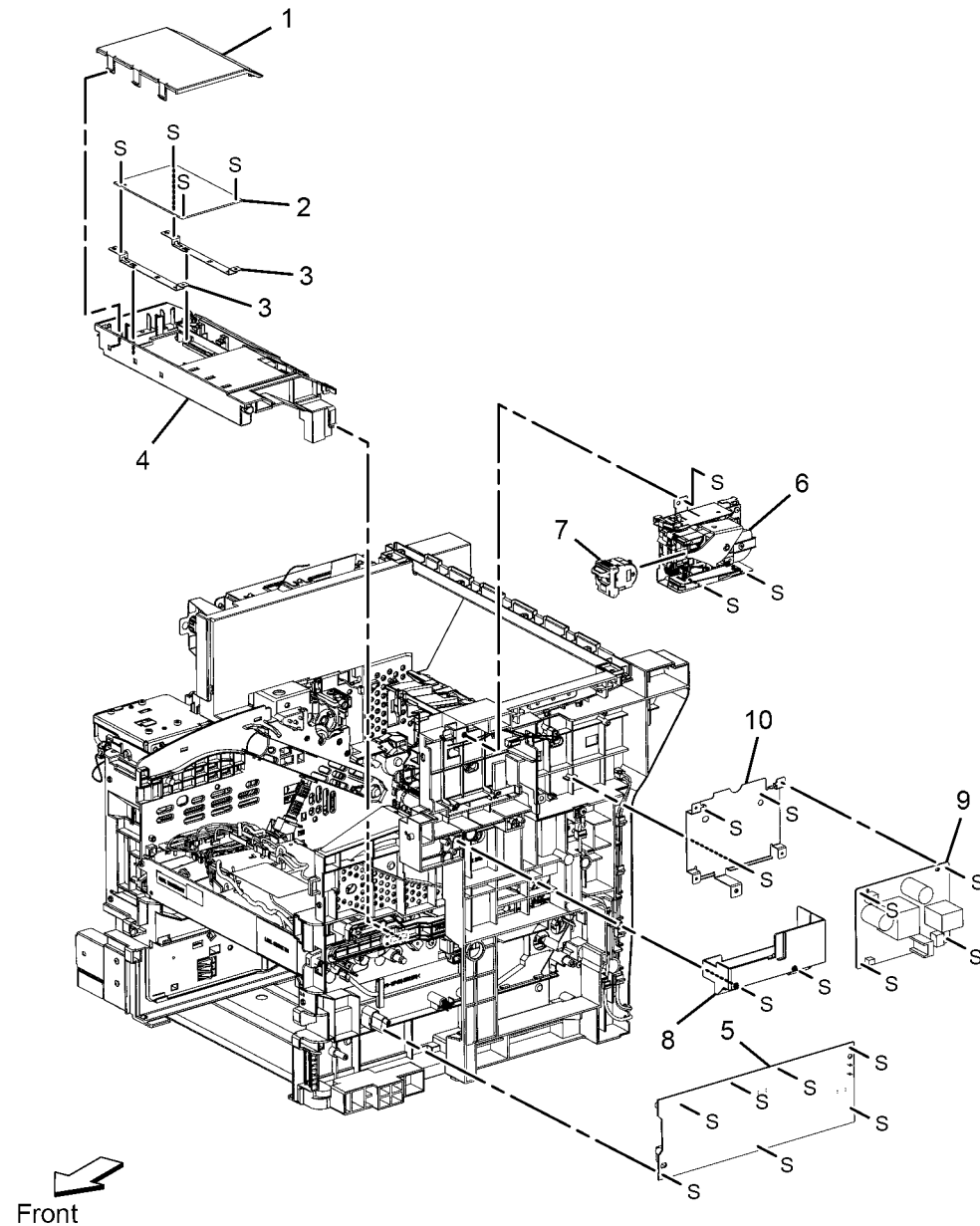

0518002A-BUR

PL 18.3 Electrical (3/3)

Item	Part	Description
1	-	Harness Assy MCU-ESS
2	-	Harness Assy MCU-LVPS
3	-	Harness Assy MCU 24V
4	-	Harness Assy MCU-Fusing100
5	-	Harness Assy MCU-DISP MOT
6	-	Harness Assy MCU-XERO CRUM
7	-	Harness Assy MCU-HVPS
8	-	Harness Assy MCU-ROS
9	-	Harness Assy LVPS-Drawer 100
10	-	Harness Assy SubLV-LVPS
11	-	Harness Assy SubLV-IITmcu
12	-	Harness Assy SubLV-Stapler Assy
13	-	Harness Assy LVPS-Drawer 200
14	-	Harness Assy MCU-Fusing200

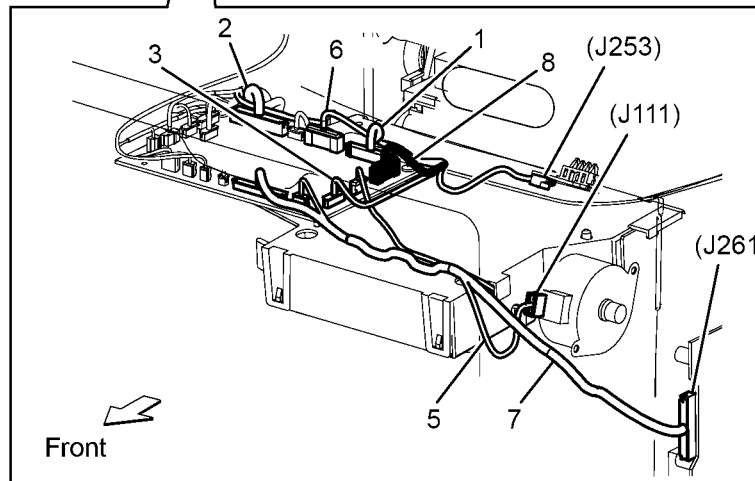
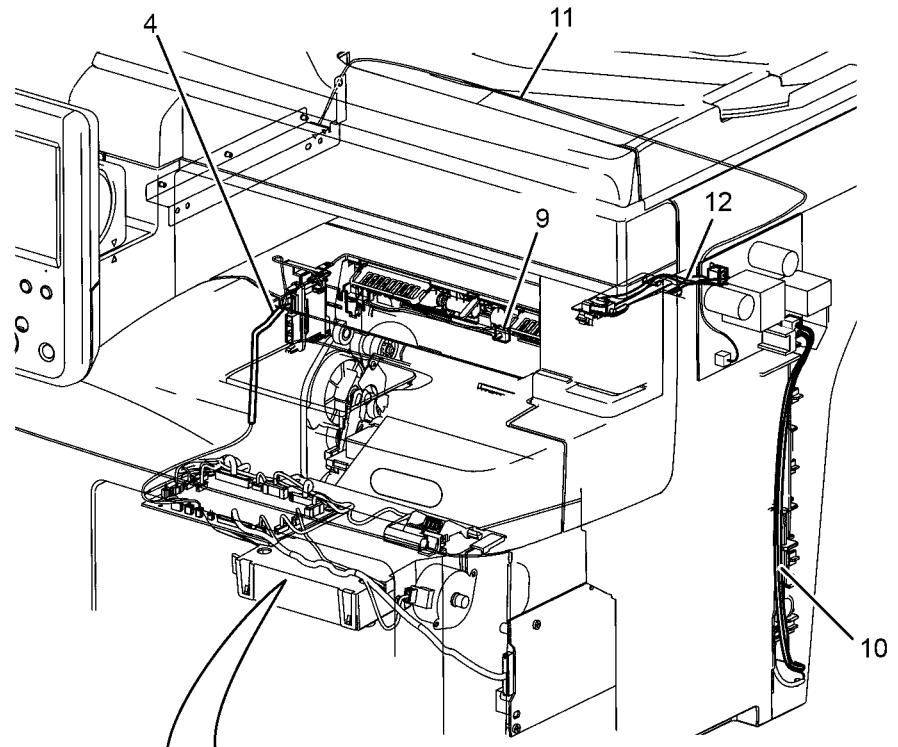

0518003A-BUR

PL 18.4 Electrical (4/4)

Item	Part	Description
1	-	Harness Assy INLET 100
2	-	Bracket Switch
3	-	Harness Assy IIT Control-ESS
4	-	Flat Cable IIT Control-ESS
5	-	Harness Assy IIT Control-ESS 2
6	-	Harness Assy IIT MCU-LVPS
7	-	Harness Assy ESS-LVPS
8	-	Harness Assy LVPS-I/L SW - Front
9	-	- Harness Assy LVPS-I/L SW - Rear
10	-	Harness Assy LVPS-Fusing 100
11	-	Harness Assy LVPS-Fan Main
12	-	Harness Assy LVPS-Fan Rear
13	-	Harness Assy INLET 200
14	-	Harness Assy LVPS-Fusing 200
98	-	KIT AC Inlet 220V
99	-	KIT AC Inlet 110V

99 { 1, 2

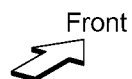
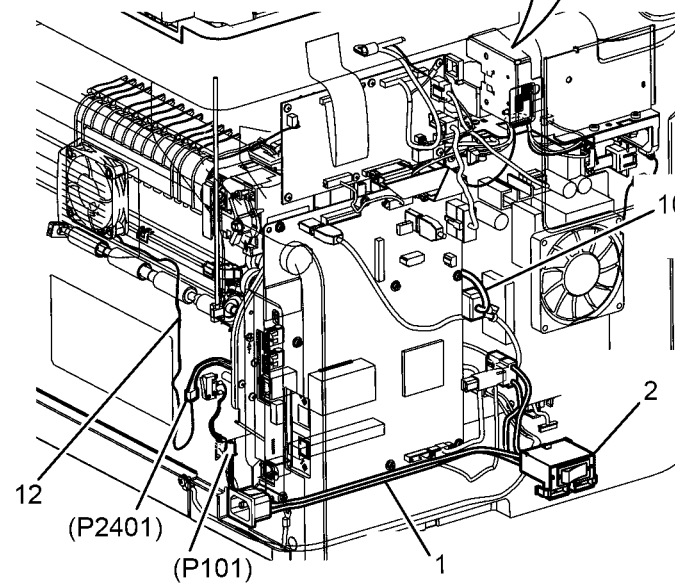
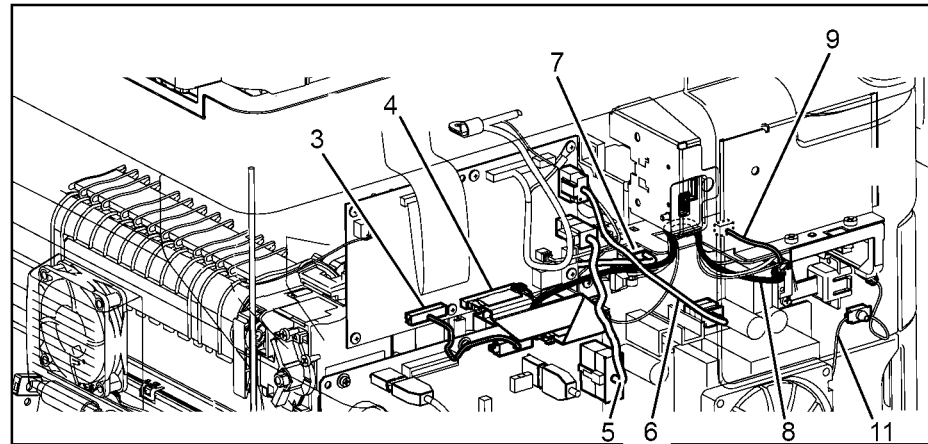

0518004A-BUR

PL 19.1 Covers (1/3)

Item	Part	Description
1	-	CVR Front (p/o item 96)
2	-	Actuator Interlock (p/o item 96)
3	-	Spring Interlock (p/o item 96)
4	-	Holder Interlock (p/o item 96)
5	-	Label MSI Instruction (p/o item 96)
6	-	CVR Front Top (p/o item 97)
7	-	CVR Extension (p/o item 99)
8	-	CVR Extension 2nd (p/o item 99)
9	-	Plate Assy Logo XC (p/o item 97)
10	822E04811	CVR Side Right
11	822E04872	CVR Stapler
12	822E04891	CVR Window Stapler
13	822E04851	CVR Side Right Out
14	-	CVR Side Right Inner
96	604K90570	Kit CVR Assy Front
97	604K90580	Kit CVR Assy Front Top
99	604K85900	Kit CVR Assy Extension

96 { 1-5
 97 { 6, 9
 99 { 7, 8

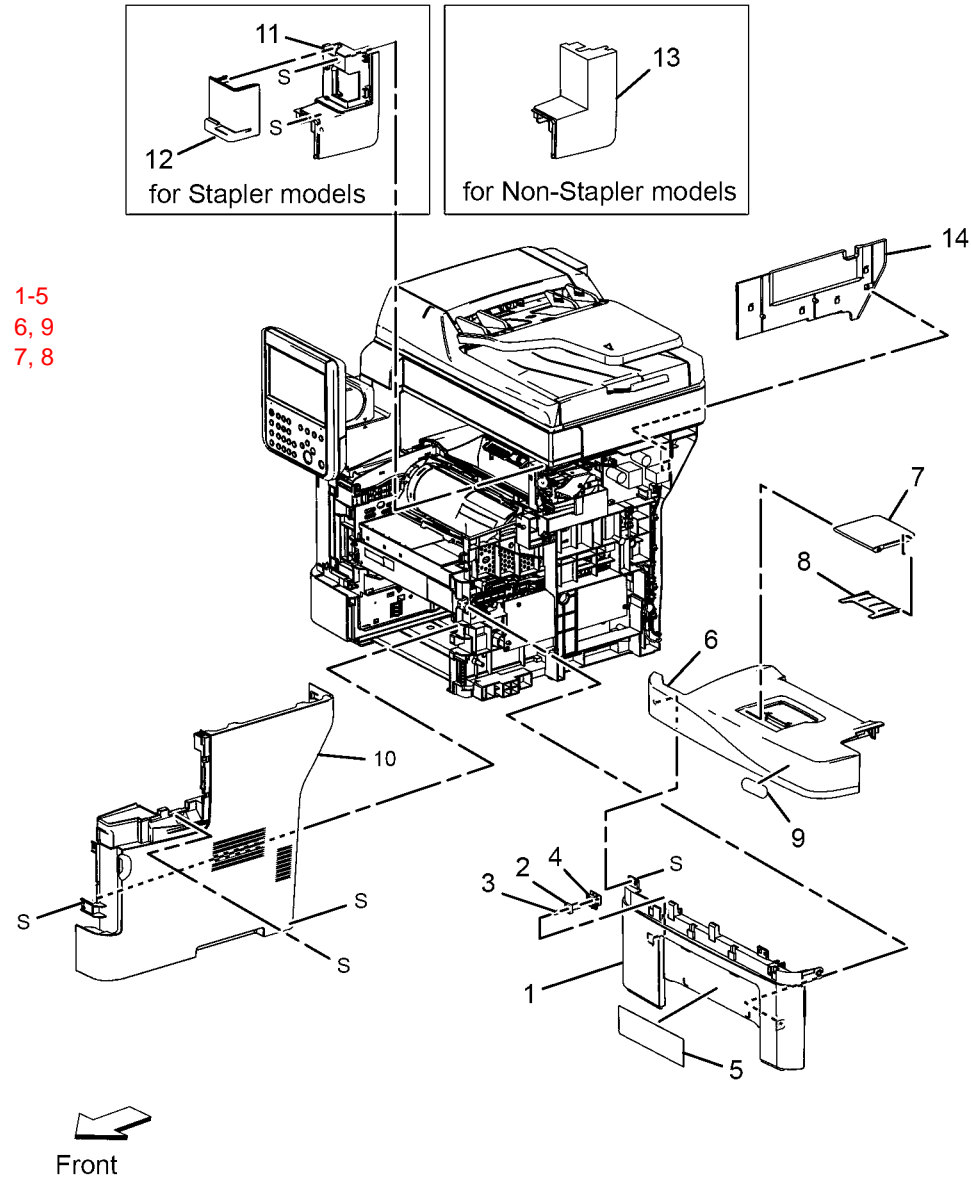

0519001A-BUR

PL 19.2 Covers (2/3)

Item	Part	Description
1	822E04641	CVR Side Left
2	822E04651	CVR Side Left Rear
3	822E08260	CVR Rear Under
4	-	Guide Harness Under Rear
5	032E43511	Guide Harness SubLV
6	-	CVR Exit Top
7	-	CVR Exit
99	848K62912	Kit CVR Assy Exit

99 { 6, 7

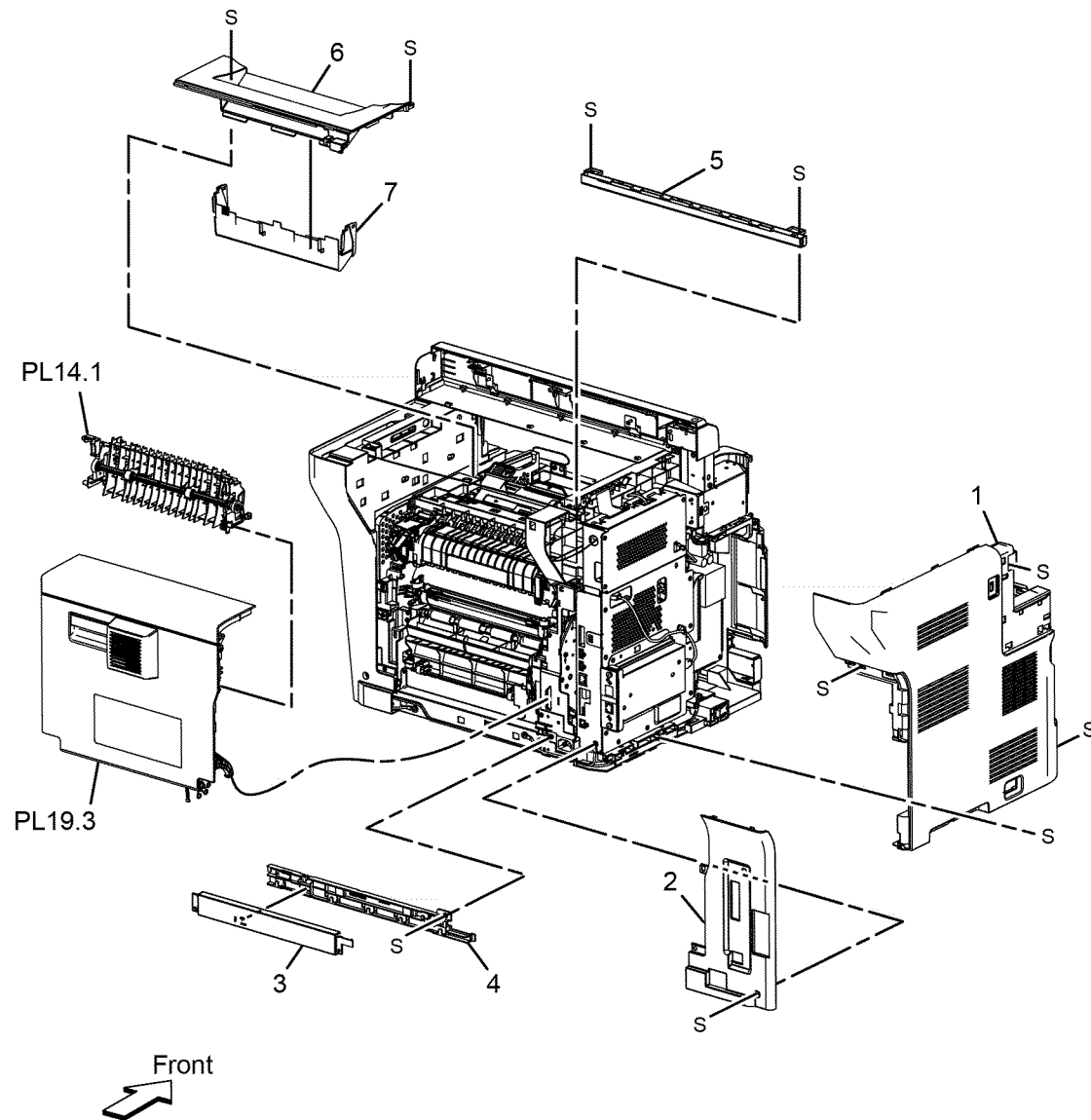

0519002A-BUR

PL 19.3 Covers (3/3)

Item	Part	Description
1	–	CVR Rear
2	–	CVR Rear Top
3	–	CVR Latch Rear
4	–	Latch Rear
5	–	Chute Dup Out
6	–	Spring Latch Right
7	868E76893	Strap Rear
8	–	Guide Harness Rear
9	127E86631	Fan Rear (Sub-Fan)
10	–	Screw TP
11	054K48100	Chute Assy Duplex
99	604K85650	Kit CVR Assy Rear

99 { 1-10

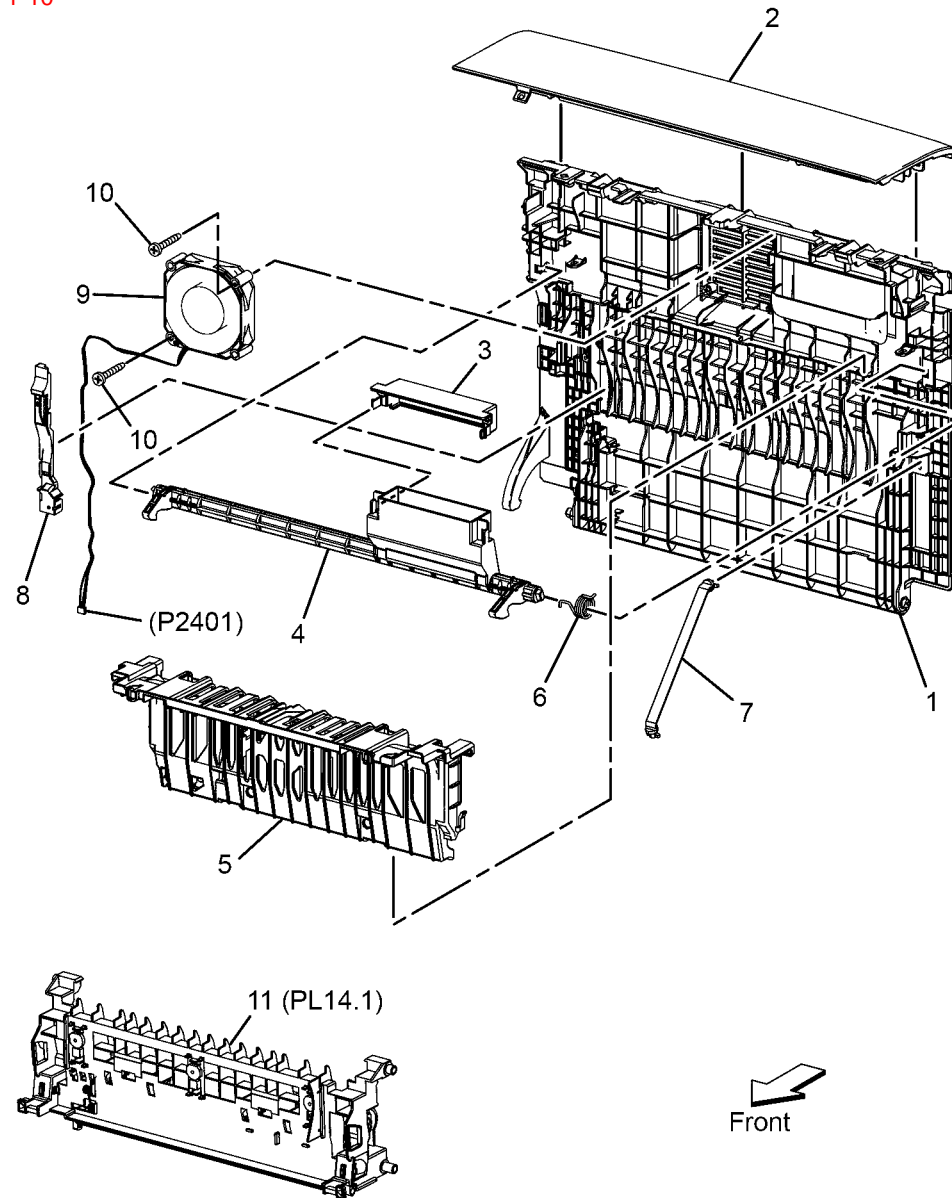

0519003A-BUR

PL 21.1 IIT/DADF

Item	Part	Description
1	059K81533	DADF Assy
2	-	Cover Top ADF (p/o item 98)
3	-	Roller Assy ADF (p/o item 97)
4	-	Separation Pad (p/o item 97)
5	-	ADF Frame Assy
6	-	--
7	-	--
8	-	--
9	003K89860	Hinge Assy-Right
10	003K89140	Hinge Assy-Left
11	050K71060	ADF Tray Assy
12	-	--
13	-	--
14	062K25594	IIT Assy
15	-	--
16	-	--
17	-	Stopper Plate L (p/o item 98)
18	-	Stopper Plate R (p/o item 98)
19	-	PF 1 Idle Spring (p/o item 98)
20	-	Idle Roll Assy (p/o item 98)
97	604K85850	Kit DADF Pick Up Module (Mid)
98	604K85860	DADF Assy Top Cover (Mid)

1 { 2-13, 15-20
 97 { 3, 4
 98 { 2, 17-20

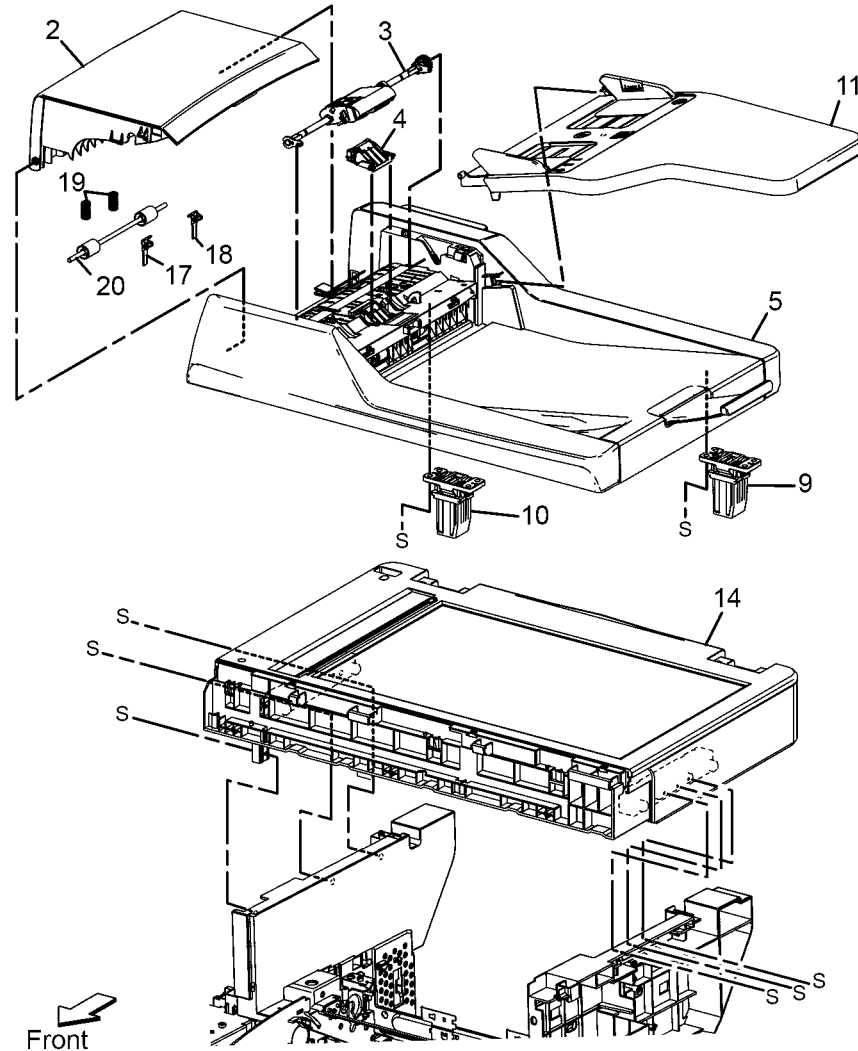

0521001A-BUR

6 General Procedures

General Procedures

GP 1 Service Diagnostics Entry and Exit	6-3
GP 2 Fault Codes and History Logs	6-4
GP 3 Customer Administration Tools	6-6
GP 4 How to Switch Off or Switch On the Printer	6-9
GP 5 Service Copy (Tools) Mode	6-10
GP 6 Electrostatic Discharge Prevention	6-10
GP 7 Machine Specifications	6-11
GP 8 General Disassembly Precautions	6-11
GP 9 Installing System Software	6-12
GP 10 How to Check a Motor	6-15
GP 11 How to Check a Sensor	6-16
GP 12 How to Check a Solenoid or Clutch	6-16
GP 13 How to Check a Switch	6-17
GP 14 Cloning Network Configurations	6-17
GP 15 N/A	6-20
GP 16 Separate System Modules	6-21
GP 17 External Fax Line Test	6-22
GP 18 Printing Reports	6-22
GP 19 Intermittent or Noise Problem	6-23
GP 20 How to Safely Lift or Move Heavy Modules	6-24
GP 21 Machine Lubrication	6-24
GP 22 Installation Space Requirements	6-25
GP 23 First Print Output Time	6-26
GP 24 Restriction of Hazardous Substances (RoHS)	6-26
GP 25 Remote Control Panel	6-27
GP 26 Media Specifications	6-28
GP 27 Environmental Data	6-29
GP 28 Toner CRUM Conversion	6-29

Diagnostic Utilities

dC104 Usage Counters	6-31
dC108 Software Version	6-31
dC120 Fault Counters	6-32
dC122 Fault History	6-32
dC131 NVM Read/Write	6-33
dC132 Serial Number Restore	6-35
dC135 CRU/HFSI Status	6-36
dC140 Analog Monitor	6-36
dC188 Service Mode Exit	6-37
dC301 NVM Initialization	6-37
UI Panel Diagnostics	6-39
dC312 Network Echo Test	6-40
dC330 Component Control	6-40
dC361 NVM Save and Restore	6-44
dC612 Print Test Pattern	6-45
dC945 IIT Calibration	6-46

Change Tags

Change Tags	6-47
-------------------	------

This page intentionally left blank

GP 1 Service Diagnostics Entry and Exit

Purpose

This procedure describes the following items:

- How to enter Service Diagnostics locally
- The Service Diagnostics screen.
- How to exit Service Diagnostics.

NOTE: When Service Diagnostic mode is entered, all existing print jobs are suspended. All scheduled jobs are held in a queue until Service Diagnostics exits.

To enter Service Diagnostics remotely, refer to GP 25.

Description

The WorkCentre 3655 has built-in diagnostics that allow access to sensors, clutches, solenoids, motors, printer status, and some NVRAM access. Using these tests, service technicians should be able to diagnose problems quickly and isolate which component or assembly needs replacement.

The printer's operating system monitors sensors located throughout the print engine and attached options. Sensors are used to monitor media handling and mechanical activity along the entire media path. As a sheet travels along the paper path, sensors change state temporarily to indicate the sheet's presence. If the pattern of sensor state changes differs from the expected timing for a particular media size and path, the sensor where the timing difference occurs identifies the error to report. However, having the error message information does not necessarily pinpoint the problem. Sensor signals locate where, but often cannot identify why. Motors, belts, gears, solenoids, and numerous other parts are involved in media transport. The Service Diagnostics' suite of tests and utilities are the best tools available to pinpoint the root cause behind the reported error.

If confronted with an error that requires more than a cursory investigation to clear or when directed by a troubleshooting procedure, use Service Diagnostics to exercise selected sub-assemblies or parts in the vicinity of the reported error. Diagnostic tests are controlled from the Control Panel.

Procedure

To enter Service Diagnostics locally:

1. Press and hold 0 (zero) for at least 5 seconds.
2. While holding 0 (zero), press and release the Start button.
3. Enter 6789 on the login screen and touch Enter.
4. The Service Info tab is displayed upon entering Service Diagnostics as shown in Figure 1.

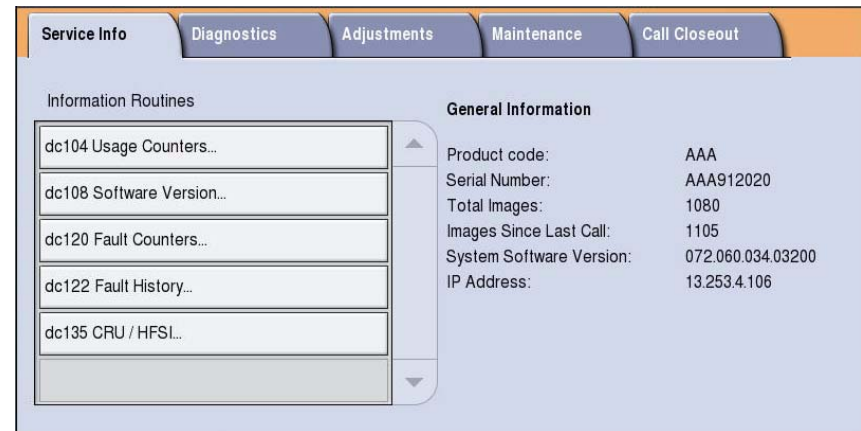

Figure 1 Service Diagnostics interface

Service Diagnostics tabs

When the Service Diagnostic screen is displayed, these tabs are available: **Service Info**, **Diagnostics**, **Adjustments**, **Maintenance**, and **Call Closeout**. Touch a tab to open that group. Touch a dC routine to launch it.

- **Service Info**
This is the default tab for Service Diagnostics. It contains the following:
General information (serial #, product code, image count, s/w version, IP address).
dC104, dC108, dC120, dC122 and dC135
- **Diagnostics**
This tab contains:
dC140, dC312, dC330 and dC612.
- **Adjustments**
This tab contains:
dC131, dC301, dC361 and dC945.
- **Maintenance**
This tab contains:
dC120, dC122, dC132, and dC135.
- **Call Closeout**
This tab allows you to choose whether the printer reboots when you exit diagnostic mode, and whether fault counters are cleared. Touch **Reset Counters?** to clear fault history.

To exit Service Diagnostics:

1. Use Call Closeout to exit diagnostics mode. It is recommended that following diagnostic testing, you reboot the printer to return it to correct operation.
2. Allow diagnostics to time-out.

GP 2 Fault Codes and History Logs

Purpose

To describe access to fault history, explain fault code structure, and define error messages and codes generated by the printer.

Description

The printer tracks and reports errors in a number of ways. The two types of error reporting discussed here include:

- Error messages and fault codes displayed on the Control Panel as shown in Figure 1.
- Error and fault code history stored in the printer.

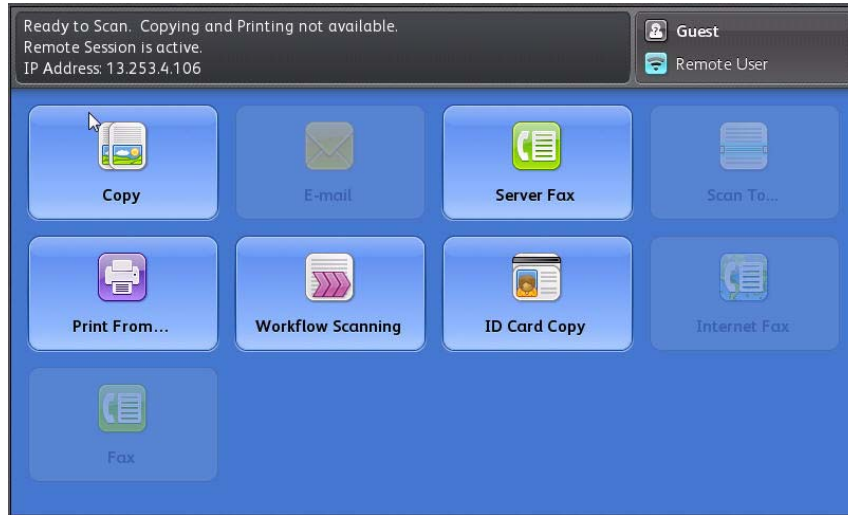

Figure 1 Home screen fault code display

Fault history lists the most recent printer fault codes with a time and date stamp. Use the fault code to determine the appropriate troubleshooting procedure. To access fault history files from the Control Panel, refer to Accessing Fault History.

NOTE: Fault codes may appear containing different pre-fix (i.e. 089-XXX vs. 389-XXX) on the Services Home Menu and Fault History.

Function and Fault Codes

Refer to Table 1 for a list of Fault code prefixes.

Table 1 Function and Fault Code Prefixes

Chain Code	Function	Chain Code	Function
302	System Controller/UI	371	Tray 1
303	Machine Run control	372	Tray 2

Table 1 Function and Fault Code Prefixes

Chain Code	Function	Chain Code	Function
305	DADF	373	Tray 3
310	Fusing	374	Tray 4
316	Network functions	377	IOT Jam
319	Hard Drive / Image data	391	Drum Cartridge
320	Fax	392	ATC / Environmental Sensor
322	Network faults	393	Toner Dispense
341	IOT NVM	394	Transfer Roller
342	NOHAD / Fan / Drive	395	Software Upgrade
361	Laser Unit		

Accessing Fault History

Fault History is available in two locations:

- Machine Status Menu
- Service Diagnostics

NOTE: Fault history can be viewed on the Control Panel without logging in as an administrator.

Accessing Fault History from Machine Status Menu

1. Press the Machine Status button
2. Touch the Active Messages tab shown in Figure 2.

Current fault and status messages are displayed. You can select how to filter the messages displayed with the Faults and Alerts pull-down. Highlight a status message to view details.

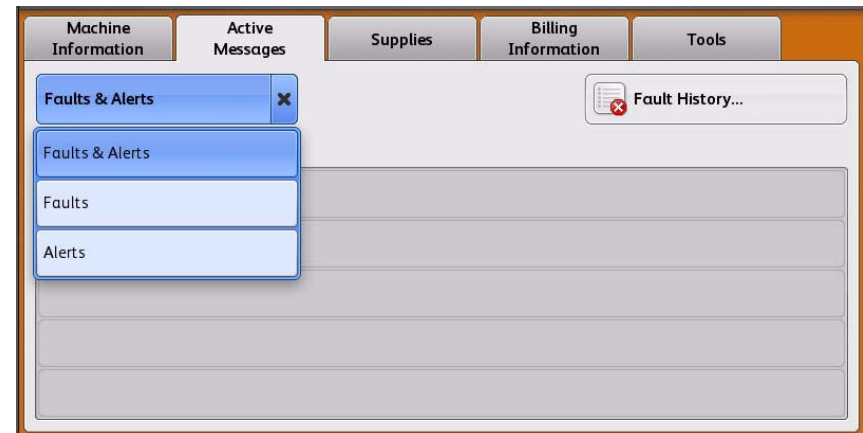

Figure 2 Filter displayed messages

3. Touch Fault History to view a listing of recorded faults as shown in Figure 3.

	Fault Code	Date	Time	Image Count
1	303.777.00	2014- 3-10	08:41:49 AM	0
2	303.777.00	2014- 2-27	08:27:49 AM	0
3	322.372.00	2014- 2-19	08:26:52 AM	1074
4	303.777.00	2014- 2-11	05:56:52 PM	0
5	303.777.00	2014- 2-11	03:09:35 PM	0
6	322.372.00	2014- 2-11	02:58:37 PM	688

Figure 3 Fault history listing

Chain Link	Description	Date & Time
303-777-00	Power Loss Detected	2014/03/10 08:41:49
303-777-00	Power Loss Detected	2014/02/27 08:27:49
322-372-00	Fax Application Un-Registration Error	2014/02/19 08:26:52
303-777-00	Power Loss Detected	2014/02/11 17:56:52
303-777-00	Power Loss Detected	2014/02/11 15:09:35
322-372-00	Fax Application Un-Registration Error	2014/02/11 14:58:37

Figure 5 Access fault details

Accessing Fault History in Service Diagnostics

1. Enter Service Diagnostics.
2. Touch Service Info.
3. Touch dC122 Fault History to display the listing as shown in Figure 4.

Chain Link	Description	Date & Time
303-777-00	Power Loss Detected	2014/03/10 08:41:49
303-777-00	Power Loss Detected	2014/02/27 08:27:49
322-372-00	Fax Application Un-Registration Error	2014/02/19 08:26:52
303-777-00	Power Loss Detected	2014/02/11 17:56:52
303-777-00	Power Loss Detected	2014/02/11 15:09:35
322-372-00	Fax Application Un-Registration Error	2014/02/11 14:58:37

Figure 4 Service Diagnostics fault history interface

4. Select the desired fault, then select Details to view the fault detail as shown in Figure 5.

Accessing Machine Status/ Tools Menu as Administrator

1. Press Log In/ Out.
2. Enter the default user name admin.
3. Touch Next.
4. Enter the default password 1111.
5. Touch Done.
6. Press the Machine Status as shown in Figure 6.

Machine Information	Active Messages	Supplies	Billing Information	Tools
Customer Support http://www.xerox.com 2226476 Model WorkCentre 3655X Serial Number AAA912020 Software Version 072.060.034.03200		IPv4 Address 13.253.4.106 IPv6 Address Enabled Host Name XRX08003760B65E		Paper Tray Status... Information Pages... Maintenance Assistant...

Figure 6 Machine status interface

7. Touch Tools to access various printer settings.

Print Process Traces

Printers equipped with a Hard Drive record system activity, To retrieve printer's activity, use this procedure:

1. Insert a thumbdrive into the front USB port.
2. Press the Menu button.
3. Select Information and press OK.
4. Select Firmware Versions and press OK.
5. Wait approximately 30 seconds as the traces are transferred to the thumbdrive.

GP 3 Customer Administration Tools

Purpose

To gain access to customer administration tools.

How to Enter Customer Administrator Tools

Perform the following:

1. Select login / out on the key pad or select guest on the UI.
2. Enter User Name 'admin' (case sensitive).
3. Select Next.
4. Enter the Password '1111' (default setting).
5. Select Enter.
6. Select machine status key (machine symbol key). To access the customer administration screen.

When the machine is password protected use Service Copy Mode (GP 5) to access device, network settings. Perform the following:

NOTE: Not all Admin settings are available while logged in as CSE.

1. Press and hold the 0 button for approximately 5 seconds then simultaneously press the Start button.
2. Enter the passcode 2732.
3. Select Enter.
4. Select machine status key (machine symbol key) and tools. To access the customer administration screen.

NOTE: After entering customer administration tools, all existing copy jobs are canceled. The network controller will stop accepting jobs and a 'Offline' screen message is displayed. When exiting service mode an 'Online' screen message is displayed.

The tools menu map is also available in the information pages. Select Machine Status / Machine Information / Information Pages and select the Tools Menu Map.

The customer administration Tools menu contains the following features:

- Device Setting - Table 1
- Service Setting - Table 2
- Network Setting - Table 3
- Account Setting - Table 4
- Security Setting - Table 5
- Troubleshooting - Table 6

Table 1 Device Settings

Feature	Feature options	Selection
General	Energy Saver (Cannot be disabled)	Intelligent Ready Job Activated Energy Saver Timers

Table 1 Device Settings

Feature	Feature options	Selection
	Date and Time	Time Zone (GMT Offset) Date Time
	Languages / Keyboard Selection	Display Languages Keyboard Layout
	Custom Keyboard Button	Enter Button Label
	Xerox Customer Support	Phone number
	Entry Screen Defaults	Screen Defaults When Originals Detected
	Measurements	Units Numeric Separator
	Paper Size Preference	Inches / Metric
	Audio Tones	Fault Tone Conflict Tone Selection Tone
	Altitude Adjustment	Units Altitude
	Feature installation	Enter Feature Installation key
	Revert to Previous Settings	
Paper Management	Paper Type and Color	Plain / Recycled / Colour
	Paper Substitution	Enable / Disable
	Paper Size Preference	Inches / Metric
	Standard Size Required	Enable / Disable
	Tray Settings	Edit settings
	Tray Contents	Paper Size / Type
Timers	Auto Resume Timer	Auto Resume / Wait for User
	Delete Held Jobs After	Enable / Disable
	System Timeout	Enable / Disable
Input	Auto Color Detection	Scan from Document Glass / Scan from Document Feeder
	Photo / Text Settings	Recognition
Output	Contention Management	Priority / First In, First Out
	Within Job Offsetting	Enable / Disable
Supplies	Enter Supplies Activation	Enter Activation Code
	Enter Plan Conversion	Enter Plan Conversion
	Low Supply Warning	Set Supply Warning
	Clear Low Supply Warning	Select Warnings to Hide
	Supply Counter Reset	Reset CRU Life Count
Device Software Upgrade	Allow Upgrade	Enable / Disable

Table 1 Device Settings

Feature	Feature options	Selection
Quick Setup Home	IP Address / contact number	-
Display Brightness	Brighter / Darker	-
Configuration / Information Pages	-	Administrator Only Open to All Users Print Configuration at Power On Print Now
Reset UI to Factory Settings	- Cancel / Reboot	-
Interrupt Printing Enablement	-	Enable / Disable
Display Device Information	Device Parameters	Show / Hide

Table 2 Service Settings

Feature	Feature options	Selection
Service Registration	Service Home	Enable All / Disable All
Device Address Book 	Manage Import Export Export Sample	Create Address Book Records
	Copy Service Settings	Feature Defaults Toner Saver
	Edge Erase Presets	Undo / Reset / Save
	Image Shift Presets	Undo / Reset / Save
	Reduce/Enlarge Presets	Undo / Reset / Save
	Reading Order Options	Scan Order Print Order
	Auto Image Rotation	When Auto R/E Selected When Auto Paper Selected
ID Card Copy Service	Enablement	Enable / Disable
	Side 1 / 2 Shared Defaults	Reduction / Supply
	Side 1 Defaults	Type / Contrast / Background
	Side 2 Defaults	Type / Contrast / Background
	Reduce / Enlarge Presets	Percentage
Embedded Fax Settings	Fax Setup	Enable / Disable
	Feature Defaults	-
	Fax Country Setting	-
	Line 1 Setup	-
	Incoming Fax Defaults	Auto Answer Delay Paper Settings Ring Volume Secure Receive Default Output Options Advanced Capabilities

Table 2 Service Settings

Feature	Feature options	Selection
	Transmission Defaults	Automatic Redial Setup Automatic Resend Audio Line Monitor Send Header Text Batch Send
	Mailbox and Polling Policies	Received Documents Stored Documents
	Mailbox Setup	-
	Setup Fax Reports	Activity Report Confirmation Report Broadcast and Multipoll Report
	Print Fax Reports	Activity Report Protocol Report Dial Directory Report Group Directory Report Options Report Pending Jobs Report Print Now
	Fax Passcode Length	Set Length
Job Sheets	Banner Sheets	Print Banner Sheet Yes / No Print Driver Override Yes / No Banner Sheet Identification
	Output Error Sheets	Enable / Disable
	Paper Type and Color	Paper Type Paper Color
Weblet Settings	Weblet Install Policy	Allow / Do Not Allow
	Weblet Management	Add / Remove
Service Plan	Current / Change Plan	Enter Authorization Code

Table 3 Network Settings

Feature	Feature Options
Online / Offline	Status and Disconnect
Network Connectivity	Wired / Wireless / Offline
TCP/IP Settings	TCP/IP Enablement Dynamic Addressing IP Address / Host Name Subnet and Gateway DNS Configuration
Advanced Settings	Ethernet Physical Media HTTP Settings 802.1x
Network Logs	Basic Enhanced Download Basic Log File

Table 3 Network Settings

Feature	Feature Options
USB Settings	USB Connection Mode (Software Tools or Direct Print)

Table 4 Accounting Settings

Feature	Feature Options
Accounting Mode	None Auxiliary Access Xerox Standard Accounting Network Accounting
Copy Activity Report	Enable / Disable

Table 5 Security Settings

Feature	Feature Options	Selection
USB Port Security	Rear and Side Ports	Enable / Disable
Audit Log	-	Download Log
Authentication	Job Deletion	All Users System Administrator Only
Image Overwrite Security	Immediate Overwrite	Disable / Enable
	On Demand Overwrite	Standard Full Overwrite Now
	Valid Recipients	Allow any valid E-mail Address Limit to Address Book entries only
Change Admin Password		Enter New Password
IPSec		Enable from CWIS
Valid Recipients	Email / Address Book	Allow / Limit

Table 6 Troubleshooting

Feature	Feature options	Selection
Xerographic Module Cleaning	Clean the Drum	Begin
Resets	Software Reset	All Software Network Software Copy Software Reset
	Supply Counter Reset	Document Feeder Feed Roller
Network	Echo Test	Protocol Start Test
Fax	Fax Protocol Report	Protocol Report Print Now

GP 4 How to Switch Off or Switch On the Printer

Purpose

Provide instruction on how to properly switch printer power On or Off. The printer is equipped with both an on/off switch and a Power button on the Control Panel. Normally the Power button is used to power the printer On and Off. However, when service procedures require you to cycle system power or perform procedures that would expose you to the potential for electrical shock, use the shutdown procedure below.

WARNING

Do not use the on/off switch as a safety disconnect device. The on/off switch is not a disconnect device. Disconnect the power cord from the printer to isolate the equipment.

Power Down Procedure

CAUTION

Do not disconnect the Power Cord or interrupt the electricity supply before power down is complete. Data and software can become corrupted.

1. Press Power on the Control Panel. A confirmation window will open.

NOTE: *If the machine is in power save mode, the machine will exit to Ready To Scan before commencing the switch off procedure. If the machine is in software upgrade mode, a message is displayed to warn against switching off the machine.*

NOTE: *If the Control Panel is unavailable, the power down request cannot be confirmed. The printer powers down automatically after 60 seconds.*

2. Confirm by selecting Power Down.

NOTE: *If Power is pressed again before either confirm has been selected or 60 seconds has elapsed, power off is cancelled. The printer returns to normal operation.*

3. When a standard power off has been initiated:
 - Control Panel screen goes blank (Black screen).
 - Power Saver LED blinks for approximately 25 seconds.
 - Go off line and stop receiving jobs.

NOTE: *The printer will attempt to print the current sheet and send all sheets in the paper path to the output tray.*

- Stop processing any remaining jobs in the print queue.
 - Send the scan carriage assembly to the home position.
4. When the printer has switched off, switch the on/off switch to the Off position and remove the Power Cord.
 5. Wait at least 1 minute following removal of the Power Cord to allow the power supplies to completely discharge before beginning any service procedure.

Switch On Procedure

1. After a power down, wait a minimum of one minute before the printer is switched on.
2. After a service call, ensure that all service tools are removed from the printer.
3. Connect the Power Cord from the AC supply outlet to the printer.
4. Switch the on/off switch to the On position. The following occurs:

- The Interput button blinks during POST testing. POST checks that the hardware resources are available to run the operating system. If a POST fault is detected, the machine is prevented from booting.
 - The Interrupt button stops blinking as the operating system begins to load. A progress bar and software version information is displayed during loading.
 - If enabled, a Configuration Report is printed.
 - The Services home screen is displayed.
5. The machine is ready to print.
 6. If the printer switches On, but the Control Panel is blank, go to the OF 2 Control Panel Touch Screen Failure RAP.

Service Mode

The machine can be switched on directly into Service Mode, refer to GP 1.

Operational Modes

Operational modes are listed in Table 1. Power activity during each operation mode is listed in Table 2.

Table 1 Printer Operational Modes

Mode	State
Running	In operation (print, scan, data receiving)
Ready	Ready to receive data
Light Sleep	Power reduced below Ready mode
Deep Sleep	Power reduced below Light Sleep mode
Soft Off	Control Panel Power button Off, Power switch On

Table 2 Power Activity by Operational Mode

-	Running	Ready	Light Sleep	Deep Sleep	Soft Off
Fuser	Operating	Standby	Off	Off	Off
Development	On	Off	Off	Off	Off
Exposure	On	Off	Off	Off	Off
Rear Fan	On (high)	On (Low)	Off	Off	Off
LVPS Fan	On (high)	On (Low)	On (Low)	Off	Off
3.3V	On	On	On	Off	Off
5v	On	On	On	On to IP	On IIT to IP
24V	On	On	On	On MCU to IP	Off

NOTE: *Refer to Electrical Specifications for further information.*

GP 5 Service Copy (Tools) Mode

The CSE Service Copy (Tools) mode provides enhanced access to printer settings without taking the printer off-line. Service Copy mode allows you to perform a number of checks and run copies without compromising customer security settings. This mode is available if the administrator account is unavailable.

Procedure

1. Press and hold the **0** button for approximately 5 seconds then simultaneously press the **Start** button. Release both buttons after a few seconds.
2. On the Service Diagnostics Login screen, enter **2732**, then select **Enter**.
3. CSE appears in the user name area of the Services home screen.
4. Press Machine Status to access the Tools tab. The Tools available in this mode are a subset of those available in Administrator mode.

NOTE: CSE Service Copy mode will time-out and return to the Guest account after a couple minutes of inactivity.

GP 6 Electrostatic Discharge Prevention

Some semiconductor components, and the sub-assemblies that contain them, are vulnerable to damage by Electrostatic Discharge (ESD). These techniques reduce the occurrence of component damage caused by static electricity.

Be sure the power is Off and observe all other safety precautions.

- Immediately before handling any semiconductor components, drain the electrostatic charge from your body. This can be accomplished by touching an earth ground source or by wearing a wrist strap device connected to an earth ground source. Wearing a wrist strap will also prevent accumulation of additional bodily static charges. Be sure to remove the wrist strap before applying power to the unit under test to avoid potential shock.
- After removing a static sensitive assembly from its anti-static bag, replace it on a grounded conductive surface. If the anti-static bag is conductive, you may ground the bag and use it as a conductive surface.
- Do not use freon-propelled chemicals. These can generate electrical charges sufficient to damage some devices.
- Do not remove a replacement component or electrical sub-assembly from its protective package until you are ready to install it.
- Immediately before removing the protective material from the leads of a replacement device, touch the protective material to the chassis or circuit assembly into which the device will be installed.
- Minimize body motions when handling unpacked replacement devices. Motion such as your clothes brushing together, or lifting a foot from a carpeted floor can generate enough static electricity to damage an electro-statically sensitive device.
- Handle IC's carefully to avoid bending pins.
- Pay attention to the direction of parts when mounting or inserting them on circuit boards.

GP 7 Machine Specifications

Functional Specifications

Table 1 lists the functional specifications of the printer.

Table 1 Functional Specifications

Characteristic	Specifications
Printing Process	Laser exposed drum
Image System	Toner/developer drum and Fuser
Resolution	600 x 600 dpi 1200 x 1200 dpi (1/4 speed)
Scan Speed	<ul style="list-style-type: none">• 40 ipm (600x400dpi)• 50 ipm (600x300dpi)
Recommended AMPV	5,200 PV
First Page-Out (Ready)	< 5.5 sec
First Page-Out (Sleep)	< 25.5 sec
Warm-Up Time	<ul style="list-style-type: none">• From Cold Start: Less than 10 minutes• From Energy Star Mode: Less than 4 minutes
Printer Life	5 years or 600K
Operating System	<ul style="list-style-type: none">• Windows 2000/ 2003, 2008 Server/Vista/W7• Macintosh: OS 10.5 or higher• Linux

Electrical Specifications

Table 2 lists the printer's electrical requirements.

Table 2 Electrical Specifications

Characteristic	Specifications
Primary Line Voltages	<ul style="list-style-type: none">• 110 - 127 VAC +/- 10%• 220 - 240 VAC +/- 10%
Primary Line Voltages Frequency Range	47 - 63 Hz
Power Consumption at Rated Voltage Input	<ul style="list-style-type: none">• Printing: 524 W• Idle: 82 W• Low Power: 22 W• Deep Sleep: 3.1 W

GP 8 General Disassembly Precautions

Purpose

Use these precautions when disassembling and reassembling components.

Procedure

NOTE: The close proximity of cables to moving parts makes proper routing essential. If components are removed, any cables disturbed by the procedure must be restored as close as possible to their original positions. Before removing any component from the machine, note the cable routing that will be affected.

Whenever servicing the machine, perform the following:

1. Check the replacement part number.
2. Check to verify that jobs are not stored in memory.
3. Power down the printer, GP 4.
4. Use a flat and clean surface.
5. Only install authorized components.
6. Do not forcibly remove plastic components.
7. Ensure all components are in their correct position.
8. When replacing screws into plastic components, turn the screw counterclockwise to engage the original thread, then turn the screw clockwise. Do not overtighten. If a new thread is cut, the plastic component will lose the ability to hold the screw. This also applies to metal components.

GP 9 Altboot & Installing System Software

Purpose

This procedure explains how to upgrade, downgrade or reload system software.

Procedure

Determine the appropriate system software loading method by selecting the device(s) that require software and type of software loading required (Upgrade, Downgrade or Reload) see Table 1.

Table 1 Software Loading

Software Platform	Procedure	Network Controller	Copy Controller	Scanner		Marking Engine
				IIT Apps	DADF	
Platform Components	Overview		XUI-Copy Controller-Fax			IOT
Normal USB Upgrade - Recommended CSE method	DLM file placed in Upgrade folder on a USB drive. Insert after printer is fully booted. NOTE: Printer must be online and the USB port enabled. <i>See Special Circumstances below.</i>	Upgrade	Upgrade	Upgrade	N/A	Upgrade
Customer Manual Upgrade via CWIS	DLM file is loaded through CWIS Properties -> General Setup -> Machine Software -> Manual Upgrade. NOTE: Printer must be online.	Upgrade	Upgrade	Upgrade	N/A	Upgrade
Customer Automatic FTP Upgrade	DLM file is placed on an FTP server and CWIS is configured to periodically check the FTP site for updated software.	Upgrade	Upgrade	Upgrade	N/A	Upgrade
Automatic Power On Software Upgrade (POSU)	At every power on, the system checks the current version of components and compares with a copy retained on the network controller. Supported platforms are upgraded or downgraded if a mismatch exists. NOTE: Printer must be online. NOTE: Auto power on upgrade will not occur if install phase (616-14) is set to manufacturing (0) or customer install (2)	N/A	Upgrade, Downgrade	Upgrade, Downgrade	N/A	Upgrade
Regular AltBoot	DLM file placed in "Altboot" folder on a USB drive and inserted prior to powering on the printer. NOTE: Data loss will occur. Make a clone file before upgrading, then restore it afterwards (GP 13). NOTE: USB ports must be enabled. <i>See Special Circumstances below.</i>	Upgrade, Downgrade, Reload	Upgrade, Downgrade, Reload	After AltBoot POSU may occur	N/A	After AltBoot POSU may occur
Forced AltBoot / Failed Upgrade Caution : <i>Use of Forced Altboot with Disable_Data_Backup may cause the serial number to be lost in CentreWare, requiring the use of the ACAST Process described in DC132.</i>	DLM file placed in Altboot folder on a USB flash drive, along with a file called FORCED_UPGRADE (case sensitive with no file extension) and inserted before powering on the printer NOTE: Data loss will occur. Make a clone file before upgrading, then restore it afterwards (GP 13). NOTE: Adding a file called DISABLE_DATA_BACKUP (case sensitive with no file extension) will prevent the NC from keeping data that is normally retained through an AltBoot. NOTE: USB Ports must be enabled. <i>See Special Circumstances below.</i>	Upgrade, Downgrade, Reload	Upgrade, Downgrade, Reload	Upgrade, Downgrade, Reload	Upgrade, Downgrade, Reload. May require manual NVM changes	Upgrade, Downgrade, Reload
Special Circumstances	- Installing Software in Accounts That Do Not Allow USB Drives - Enabling or Disabling all USB Ports at the Control Panel - Enabling USB Ports on a Dead Machine - Lost Administrator Passcode	See attachment				

Select from the following installation options:

- Normal USB Upgrade
- Regular / Forced AltBoot

Normal USB Upgrade

NOTE: Machine must be online and the USB port must be enabled. The System Administrator should be able to determine which USB ports are enabled.

Procedure

Obtaining Software

System software is available on www.Xerox.com. To load SW onto the USB Flash Drive, perform the following:

1. Connect the flash drive to a USB port on your PWS.

NOTE: You should not have an **upgrade** and **altboot** folder in the root of the flash drive at the same time.

2. Create a folder named **upgrade** at the root level of the flash drive.
3. Navigate to the root directory of the flash drive.

NOTE: If you have more than one file with the suffix **.dlm** inside the **upgrade** folder, the latest version is automatically selected.

4. Locate the **Machine SW** folder. Inside the folder is a file with the name **WorkCentre_3655-system-sw#06112000****#.dlm**, where **** is the version number of the software. Copy this file to the **upgrade** folder on the USB flash drive.
5. Remove the flash drive from your PWS.

Loading Software

1. Switch on the printer and wait for boot up.
2. Perform an NVM Save, dC361.
3. Perform the Network Clone procedure, GP 13.
4. If possible, complete or delete all pending print jobs. If the prints jobs cannot be deleted, warn the customer that all pending jobs will be lost.
5. Before software is loaded, ensure that the machine is fully operational. Any active faults or jams must be resolved before starting this procedure.
6. Connect the USB flash drive to the Side USB port.

CAUTION

It may take several minutes for the upgrade to start. There is **NO** indication until the Control Panel displays the **Software Upgrade** screen. **DO NOT** remove the flash drive or switch Off power until the printer reboots.

7. It may take several minutes for the upgrade to start. The Control Panel displays the **Software Upgrade** screen. Progress bars for each of the software modules is displayed.
8. The upgrade process may require 15 minutes to complete. After the upgrade loads, the printer reboots. When the reboot is complete, remove the flash drive.
9. Print a Configuration Report and verify software version levels.

If the procedure is not successful . . .

Listed below are possible problems that may stop software loading:

- Incompatible USB flash drive or inactive USB port:
If the activity light on the USB flash drive never lights or flashes, the customer may have disabled the USB ports. Log into the printer's web page, select Properties tab, Security heading, and then click on USB Port Security and ensure that the USB ports are checked and enabled.
If the printer's web page cannot be accessed, look for...
- Corrupt .dlm file.
- Incorrectly named upgrade directory on USB flash drive.
- HDD corruption or failure.
- USB port disable/damage
- Control Panel failure
- ESS Board failure

Regular / Forced AltBoot

NOTE: Printer must be online and the USB port enabled. The system administrator should be able to determine which USB ports are enabled.

AltBoot should be only be used under the following circumstances:

- To attempt to reinstall corrupt software
- After replacing a Hard Drive
- To upgrade software without running multiple software upgrades.
- To downgrade software.

There are two types of AltBoot; Regular and Forced:

- A **Regular AltBoot** is used to recover from problems with the ESS Board (e.g. Disk corruption, general issues). It will upgrade all software on the ESS Board. Any other peripheral devices that need an upgrade will be handled by the Power On Upgrade feature after the AltBoot is complete and the printer has rebooted.
 - The IOT cannot be reloaded or downgraded using this feature.
 - A Regular AltBoot takes approximately 5-10 minutes.

CAUTION

The **Forced AltBoot** feature should be used with extreme caution as it will replace bootcode as well as application code. Power failure during a **Forced Altboot** while programming bootcode may result in certain options not being recoverable.

- A **Forced Altboot** will upgrade or downgrade every printer component regardless of the currently-installed software version. A **Forced Altboot** is required for recovering from corrupt application code on devices such as Fax, IOT, and IIT.
 - A **Forced Altboot** should be used if a downgrade of the IOT or IIT is required.
 - Performing a **Forced Altboot** may require 25 minutes to complete.

Procedure

Obtaining Software

System software is available on www.Xerox.com. To load software onto a USB Flash Drive, perform the following:

1. Connect the flash drive to a USB port on your PWS.

NOTE: You should not have an upgrade and altboot folder on the flash drive at the same time.

2. Create a folder named altboot at the root level of the drive.
3. **Forced AltBoot only:** Create a file named **FORCED_UPGRADE** inside the altboot folder. This is an empty file and **must not** have an extension; the AltBoot routine only checks to see that a file with this name is present. To create the empty file, do the following:
 - Open the altboot folder
 - In a blank area of the screen, right click and select "New".
 - Select "Text Document".
 - The name "New Text Document.txt" will be highlighted.
 - Type "FORCED_UPGRADE" and hit "Enter".
 - A pop-up with the message "If you change a file name extension, the file might become unusable. Are you sure you want to change it?" will appear.
 - Click on "Yes".

To eliminate corrupt data carryover, create a file called **DISABLE_DATA_BACKUP** (case sensitive with no file extension). This prevents the NC from keeping data that is normally retained through an AltBoot.

4. Navigate to the root directory of the flash drive.

NOTE: If you have more than one file with the suffix **.dlm** inside the **altboot** folder on the Flash Drive, the latest version will be automatically selected.

5. Locate the **Machine SW** folder. Inside the folder will be a file with the name **WorkCentre_3655-system-sw#061120000*****#.dlm**, where ***** is the version number of the software. Copy this file to the **altboot** folder on the USB flash drive
6. Remove the flash drive from your PWS.

Loading Software *Note : Use of Forced Altboot with Disable_Data_Backup may cause the serial number to be lost in CentreWare, requiring the use of the ACAST Process.*

1. Switch On printer power and wait for the printer to boot.
2. Perform an NVM Save, dC361.
3. Perform the Network Clone procedure, GP 14.
4. If possible, complete or delete all pending print jobs. If the prints jobs cannot be deleted, warn the customer that all pending jobs will be lost.
5. Before software is loaded, correct any active faults or jams.
6. Switch Off the printer.
7. Connect the USB flash drive to the Side USB Port.
8. Switch On the printer.
9. The Control Panel displays the **Software Upgrade** screen. Progress bars for each of the software modules are displayed.
10. The AltBoot process should complete after approximately 5 minutes. When finished, the Control Panel displays **Upgrade Complete. Remove USB Drive and press "0" in UI.** Remove the flash drive before hitting "0" or the printer will restart the upgrade.
11. If the AltBoot process fails, the **AltBoot failed** screen appears. Follow the on screen instructions. Restart the procedure.

NOTE: Do not switch off the machine until prompted to do so. During the next few steps, the Hard Drive is being encrypted. Switching Off the printer can cause only partial encryption of the Hard Drive.

12. The Control Panel displays the **Data Encryption/Decryption** screen after the data encryption is complete. This takes about 5 minutes. If there is a problem during encryption, a reset printer screen appears. Do not power Off unless the "RESET MACHINE" screen is displayed. In this case, cycle system power and check software version levels. If software is not correct, start over.
13. The printer reboots several times before returning to ready. In some instances a power on failure screen may appear. Cycle system power to clear the fault.
14. Perform an NVM Restore, dC361.
15. Perform a Network Clone Restore, GP 14.

If the procedure is not successful . . .

Listed below are possible problems that may stop AltBoot software loading:

- Incompatible USB flash drive.
- Corrupt .dlm file.
- Incorrectly named upgrade directory on USB flash drive.
- HDD corruption or failure.
- USB port disable/damage
- Control Panel failure
- ESS Board failure

GP 10 How to Check a Motor

This procedure describes how to check a motor:

Initial Actions

WARNING

Switch off the electricity to the machine. Disconnect the power cord from the customer supply while performing tasks that do not need electricity. Electricity can cause death or injury. Moving parts can cause injury.

1. Check that the motor is free to rotate.
2. Check that all the motors mechanisms are clean, free to move and lubricated correctly.
3. Enter the component control code for the motor, refer to dC330. Run the motor for 30 seconds, if the motor shows signs of or can be heard to slow down, the motor is defective. Replace the motor.
4. Perform the appropriate procedure:
 - Two Wire DC Motor
 - DC Motor with Integral Encoder
 - Four Wire Stepper Motor

NOTE: The voltages, PJ numbers, pin numbers and PWB names shown are an example only. Go to the wiring diagram associated with the RAP for the correct information.

Two Wire DC Motor

NOTE: In cases where the motor may be driven forward or backward, the same two feed wires are used, but the voltages on them are reversed, to reverse the motor direction. Such motors may have two component control codes, for forward and reverse. A typical application is a tray lift motor with a tray-up and a tray-down direction

1. Check the drive voltage when the component control code for the motor is entered. If the drive voltage is measured, install a new motor. If the drive voltage is not measured, continue to the next step.
2. Check that the drive voltage can be measured on the PWB when the component control code for the motor is entered. If no drive voltage is measured, check the power to the PWB. If the power is good install a new PWB. If the drive voltage is measured at the PWB, check the wiring to the motor. Repair or install new wiring.

DC Motor with integral Encoder

NOTE: This type of motor has the normal drive voltages for a DC motor, plus the +3.3V and 0V lines for the encoder. The encoder has two outputs, A and B, producing pulses when the motor is on. When the motor is running in one direction, the encoder A pulses lead the encoder B pulses. In the other direction, encoder B pulses lead encoder A pulses. In this way the controller can detect that the motor is running in the correct direction.

Check the operation of the motor as follows:

1. Check the drive voltage when the component control code for the motor is entered. If the drive voltage is present at the motor, install a new motor. If the drive voltage is not present, go to step 2.

2. Check that the drive voltage at the driver PWB when the component control code for the motor is entered. If the drive voltage is present, check the wiring and connectors to the motor. If the drive voltage is not present, check the power to the driver PWB. If the power to the PWB is good, install a new driver PWB.

NOTE: When checking for pulses, use a standard digital multimeter. Using the DC volts range, or the AC volts range, expect to obtain a reading greater than 1V and less than 4 volts, while the motor is running. The actual value depends on the meter's reaction to square waves and to the particular frequency of the pulses. It is common to obtain a reading of 2 to 3 volts. If the meter has a minimum and maximum recording facility, expect a maximum value of around +4.9 volts DC, and a minimum value of around +0.2 volts DC

Check the operation of the encoder as follows:

Check for pulses when the motor is running. If pulses are present, check the driver PWB. If pulses are not present at the motor, check the wiring to the motor and repair to install new wiring. If pulses are present, install a new driver PWB.

Four Wire Stepper Motor

NOTE: A stepper motor with an internal open circuit may appear to be fully functional under dC330 component control. However, under normal operation it will run with intermittent failure. Use the multimeter to check stepper motor coil resistance.

1. Refer to Figure 1. Disconnect PJ111. Check the +24V supply and the phase pulses to GND when the component control code for the motor is entered. If the supply and pulses are present, install a new motor.
2. Check the connectors and wiring to the motor. Repair or install new wiring, as necessary.
3. Disconnect PJ11. Check the +24V. If +24V is not present, check the power to the PWB. If the power is good, install a new PWB. Check the phase pulses at the PWB. If the phase pulses are not present at the PWB, install a new PWB

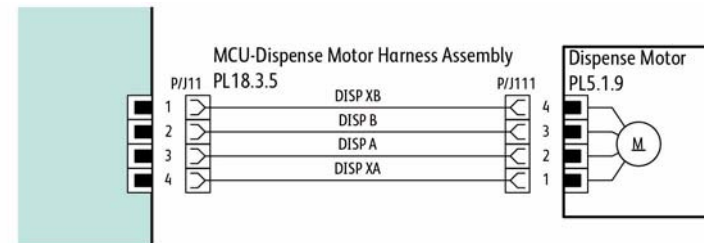

s3655-236

Figure 1 Example motor wiring diagram

GP 11 How to Check a Sensor

Use this procedure to check the operation of all types of sensor.

NOTE: Some sensors have a resistor within the sensor and other sensors require a resistor on the PWB. The resistor limits the current through the LED. The voltage to the sensor LED with an external resistor, is typically 1.2V.

NOTE: The voltages, PJ numbers, pin numbers and PWB names shown are examples only. Go to the wiring diagram associated with the RAP for the correct information.

NOTE: In some cases, two sensors are used to form an interruptible beam of light. In these cases, the LED of one sensor and the sensing element of the other sensor are used. Treat the two sensors as if they were housed in the same body for diagnostic purposes, ignoring the unused part of each sensor. If the combined sensors do not operate correctly and the beam path is clear of obstruction, it may be necessary to install both new sensors.

Quick Sensor Check

Enter the component control code for the sensor, refer to dC330. Actuate the sensor. If the display changes, the sensor operates correctly. If the display does not change, perform the procedure.

Procedure

For the sensor in the wiring diagram shown in Figure 1:

1. Actuate the sensor and check for a change in voltage at PJ27, pin 3. If the voltage changes, install a new PWB. If the voltage does not change, continue to the next step.
2. Disconnect PJ271. Check for +3.3V and 0V (GND) on the harness.
3. Disconnect PJ27 and PJ271. Check the harness and the connectors for continuity.
4. Check for +3.3V and 0V (GND) at the PWB.
5. If necessary, install new components or repair the wiring.

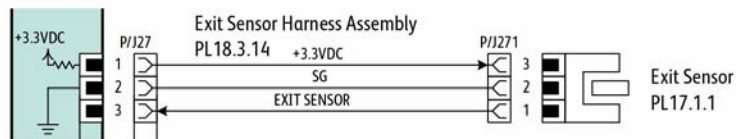

s3655-237

Figure 1 Example sensor wiring diagram

GP 12 How to Check a Solenoid or Clutch

Use this procedure to check a clutch or solenoid.

Initial Actions

WARNING

Switch off the electricity to the machine. Disconnect the power cord from the customer supply while performing tasks that do not need electricity. Electricity can cause death or injury. Moving parts can cause injury.

1. For a clutch, check that the shafts, gears, rolls etc., associated with the clutch are free to rotate, clean and lubricated where applicable.
2. For a solenoid, check that the solenoid is free to actuate and that the mechanisms associated with the solenoid are free to move.

Procedure

NOTE: The voltages, PJ numbers, pin numbers and PWB names shown are an example only. Go to the wiring diagram associated with the RAP for the correct information.

NOTE: When a solenoid is energized in diagnostics, movement is seen. When a clutch is energized in diagnostics, the sound of the clutch action is heard. If possible, run the motor connected to the clutch to confirm when the clutch is energized

1. Enter the dC330 output code for the clutch or solenoid. If the clutch or solenoid does not energize, continue with step 2.
2. Refer to Figure 1 to disconnect PJ17, check for +24V at pin 1 on the wiring side of the connector, If the voltage is not correct, trace the faulty component.
3. Reconnect PJ17, enter the dC330 output code for the clutch or solenoid, while measuring the voltage between pin 1 and ground. If the voltage does not change when the code is entered, Install a new PWB.
4. There may be an intermittent fault, perform the actions that follow:
 - a. Check the wiring. Repair or install new components as necessary.
 - b. Operate the clutch or solenoid under normal running conditions. If the clutch or solenoid operates intermittently or with hesitation, install new parts.
 - c. Check that the clutch or solenoid has enough drive to operate the mechanism to which it is attached, if necessary install a new clutch or solenoid.

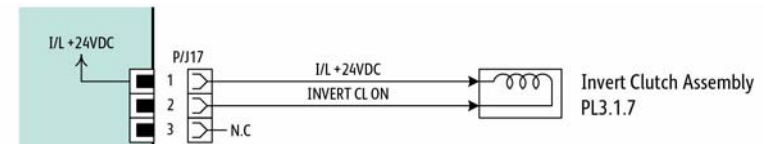

s3655-238

Figure 1 Example clutch wiring diagram

GP 13 How to Check a Switch

Use this procedure to check the operation of a switch.

NOTE: Figure 1 shows an interlock switch actuated by the closing of a door.

Initial Actions

WARNING

Switch off the electricity to the machine. Disconnect the power cord from the customer supply while performing tasks that do not need electricity. Electricity can cause death or injury. Moving parts can cause injury.

Manually check that the switch operates. Ensure that the magnet or other actuator has enough mechanical movement to operate the switch.

NOTE: The voltages, PJ numbers, pin numbers and PWB names shown are an example only. Go to the wiring diagram associated with the RAP for the correct information.

Procedure

1. Enter diagnostics and check the switch. The switch is operating correctly, check and adjust the mechanism that actuates the switch
2. Refer to Figure 1, then disconnect the switch.
3. +5V is available between pin 1 and pin 2 on the wiring side of the connector.
4. +5V is available at PJ231 between pins 1 and 2 on the PWB.
5. Check the supply voltage. If +5V is available, install a new PWB.
6. Check the wiring between PJ231 and the switch. Repair or install new parts as necessary.
7. Install a new switch.

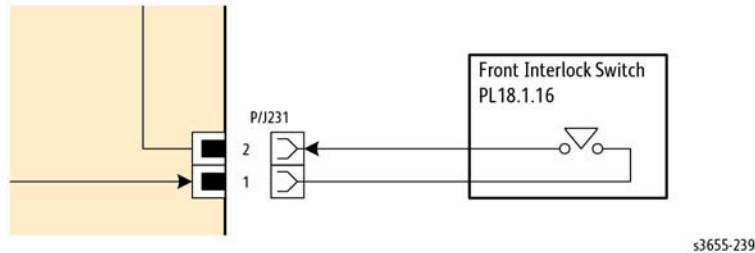

Figure 1 Example switch wiring diagram

GP 14 Cloning Network Configurations

Purpose

Use this procedure establish a network connection between the PWS and printer to create a copy of network configuration settings and distribute these settings to multiple devices on the network. This cloning process can also be used to backup and restore network settings lost during an Altboot software load.

NOTE: To establish a direct Ethernet connection between the PWS and printer requires the printer's driver installation CD-ROM, a crossover cable, and the PWS.

Depending on the printer, a Windows 7 (W7) driver might not be available on the printer's driver installation CD-ROM. If not, download the driver from Xerox.com under the Support and Drivers page. W7 has two kernal types, 32 and 64-bit. If you try to install the wrong driver, Windows displays an error to indicate the driver is incorrect. To check the kernal type, click on Start, in the right column, right click on Computer and select Properties, you will see the kernal type listed as System Type.

Establishing a LAN connection

Use these steps to establish a Local Area Network (LAN) connection between the PWS and printer using a crossover cable.

NOTE: Record the original data for every change you make. You may or may not need to reset the IP address, depending on PWS usage and local network practice.

1. Print a Configuration Report, GP 18. Note the printer's IP address.
2. Connect the crossover cable between the PWS and printer.
3. Open a Command window (CMD) on the PWS.
 - If running XP, click on **Start**, then select **Run**. Type **CMD** in the Run dialog box and press **Enter**.
 - If running W7, select **Start** and in the Search box above the Start button, type **CMD** and press **Enter**.

NOTE: If the Windows key is enabled (the key located in the lower left corner with the Microsoft logo), hold the Windows key down, press R and release both keys to open the Run dialog box.

4. Type **ipconfig** at the prompt, then write down the current network settings displayed. Restore these settings when the LAN connection is no longer needed.

NOTE: Use the IPv4 address for the Local Area Connection, not the address listed under Wireless Ethernet Connection (if enabled in your laptop).

5. Check the IP addresses of the PWS and printer. If the PWS has been connected to the same subnet, the PWS and printer address should share the same values for the first three and have a different value for the forth number. Refer to Table 1 for an example.

Table 1 Example LAN Settings

	Printer	PWS / Laptop
IP Addresss	192.168.0.2	192.168.0.5
Subnet Mask	255.255.255.0	255.255.255.0
Gateway/Router	192.168.0.1	192.168.0.1

If the PWS and printer share similar, but unique IP address, continue. If not, use the Set a Static IP Address on the PWS to set the PWS IP address.

6. After verifying the IP addresses are correctly configured, PING the printer.
 - a. In the Command window (where the blinking cursor is) type the word **PING**. Press the space bar once and enter the printer's IP address and press **Enter**. As an example: ping 192.168.0.2.
 - b. If the printer responds to the PING command, it replies four times. This should not take more than two or three seconds.
 - c. If the PING command times out, or responds with "host unreachable", check the IP addresses that were entered. If the IP address is correct, see Troubleshooting the Connection.
7. If the PING command replies, exit the Command window (type "exit" at the prompt and press **Enter**). This test verifies the Ethernet connection is good.
8. Install the printer driver and setup the printer as a local printer. Select connect to the printer using "other" port type. From the dialog drop down select Standard TCP/IP port.
9. For the Printer Name or IP address, enter the printer's IP address (192.168.0.2 in this example).
10. When the driver installation finishes, Select **Yes** at the Print Test Print dialog box.

NOTE: If the test page does not print, the customer could have Accounting enabled (if the device supports it) requiring that a special code is submitted with the print job before the printer prints. Test the printer using CentreWare Internet Services

11. After the test print is completed, open a web browser on the PWS.
12. In the Address Bar (in place of a web site address or URL), enter the printer's IP address (192.168.0.2 in this example)..
13. If the connection is working correctly, the CenterWareIS web page of the printer will be displayed.

NOTE: If you are unable to open the printer's webpage, verify that CentreWare Internet Services are enabled on the configuration page. Depending on the printer, this could be documented as HTTP (under protocols) or CentreWare IS (for example that is). If your web browser is set to use a Proxy address for the internet connection, you will not be able to bring up the printer's webpage as you will have no connection to that proxy server while directly connected to the printer via crossover Ethernet cable. Refer to PWS Browser Proxy Server Setting for instructions on Internet Explorer proxy configuration.

Creating the Clone File

1. When the **Centroware® Internet Services** window opens, select the **Properties** Tab. Click on the **General Setup** link, then the **Cloning** link as shown in Figure 1.

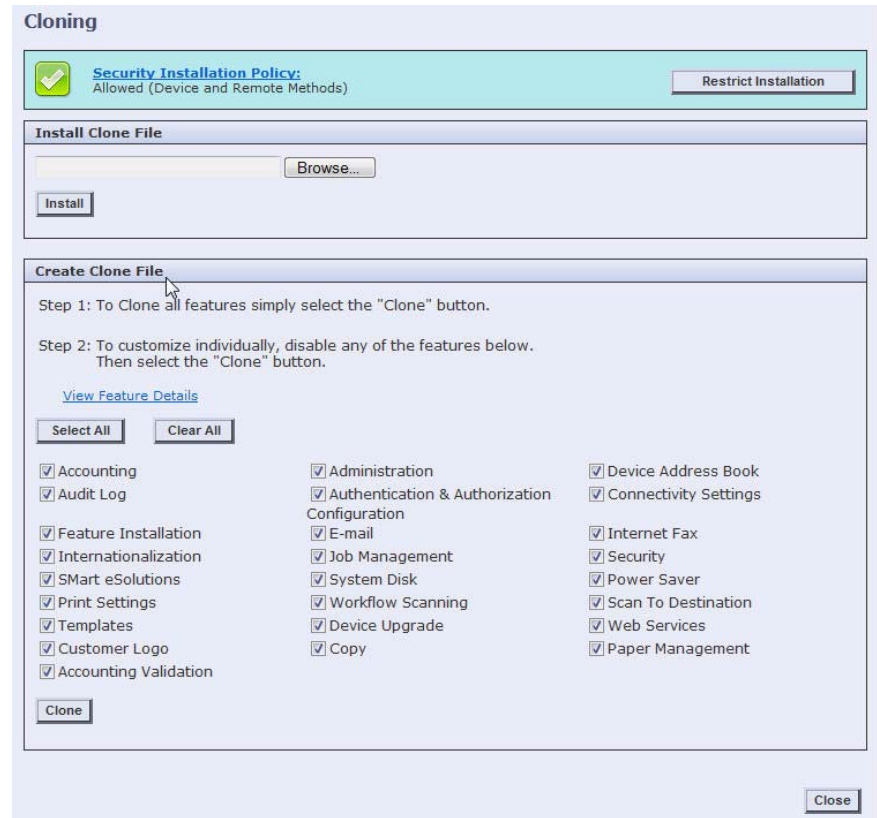

Figure 1 Cloning interface

2. Scroll down the page to see critical information about the cloning process. Click the **View Feature Details** link to get a list of data that is backed up and/or restored using the Cloning Feature.

Saving settings to a Clone file

1. Select the **Clone** button under the **View Feature Details** link Figure 1.

NOTE: If the customer has enabled Administrator Password, you will be asked for a user name and password. Defaults are **admin** as the user name, and **1111** for the password.

CAUTION

- Do NOT attempt to open the clone file as it may corrupt the file.
2. Right click on **Cloning.dlm** to save the clone file as shown in Figure 2.

NOTE: When the file is saved, a .txt extension may automatically be placed at the end of the file name. Before loading this clone file, navigate to the saved file, right-click on the file and select **Rename**. The correct format for the file name is xxxxxxxx.dlm.

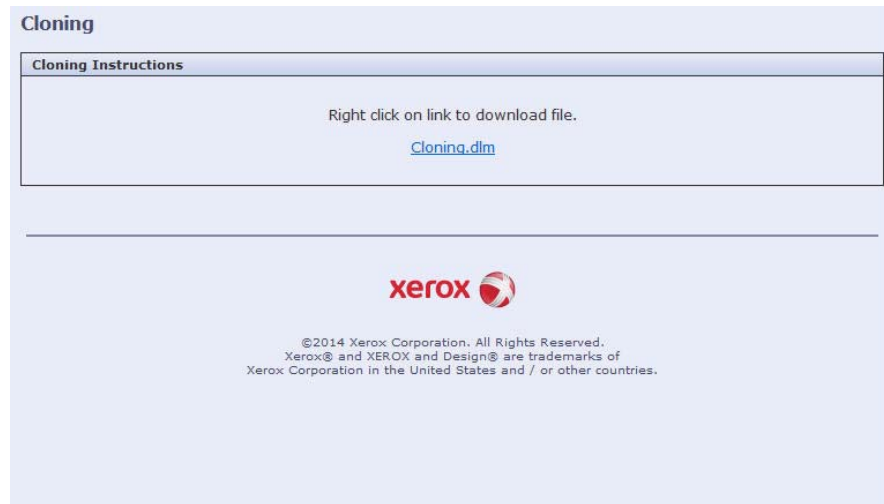

Figure 2 Save the clone file

Using the Clone file

NOTE: This procedure can be done from ANY PC connected to the network or the PWS connected to the machine using an Ethernet crossover cable. The only requirement on the PC is an Internet Browser.

1. Open Internet Explorer
2. Enter the machine's IP address in the **Address** line and select **Go**.
3. When the **Centroware® Internet Services** window opens, select the **Properties** Tab. Click on the **General Settings** link, then the **Cloning** link.
4. Scroll to the bottom of the page.
5. Use the **Browse** button to navigate to the clone file, or type the full path to the file. Click **Install**. If the printer does not reboot after five minutes, cycle system power.
6. Verify the cloned settings with a new Configuration Report.

Set a Static IP Address on the PWS

Use this procedure to manually set the PWS IP address. Instructions are given for W7 and XP.

NOTE: If the PWS has a wireless Ethernet card/adaptor installed, Windows will not use the wired Ethernet port by default until either the PWS is rebooted or you temporarily disable the wireless Ethernet card. If unsure how to disable/enable your wireless Ethernet card, restart the PWS after setting the IP address.

For W7:

1. Open the **Control Panel**.

2. Select **Network and Internet**.
3. Select **Network Sharing Center**.
4. Select **Change Adaptor Settings** in the upper left corner of the Control Panel.
5. Right-click on **Local Area Connection**, then select **Properties**.
6. On the Networking tab (for local area connection), click on **Internet Protocol Version 4 (TCP/IPv4)**, then select **Properties**.
7. Select **Use the following IP address** and enter an IP address similar to the printer to manually set the PWS IP address and subnet mask to match the printer's IP configuration settings.
8. Click **OK** twice and exit Network Connections and return to Creating the Clone File.

For XP:

1. Click **Start** and select **Control Panel**.
2. Click **Network and Internet Connections** and then select **Network Connections**.
3. Right-click on **Local Area Connection** and then select **Properties**.
4. On the General tab (for local area connection), click **Internet Protocol (TCP/IP)**, and then click on **Properties**.
5. Click **Use the following IP address** to manually set the computer's IP address and subnet mask to match the printer's IP configuration.
6. Click **OK** twice to exit Network Connections and return to Creating the Clone File.

PWS Browser Proxy Server Setting

The following steps ensure the proxy server settings are correct.

1. Open **Windows Internet Explorer**.
2. Select **Tools - Internet Options**.
3. Select the **Advanced** tab.
4. Scroll down to **HTTP 1.1 Settings**.
5. Ensure that the "Use HTTP 1.1 through proxy connections" box is **un-checked**.
6. Select **OK** to close the **Internet Options** window.
7. Close **Windows Internet Explorer**.

Troubleshooting the Connection

1. Verify the cable being used is a true crossover cable.
2. Print a new Configuration page and check that the TCP/IP area shows the IP address, Net Mask, and Gateway numbers entered.
3. If an Ethernet type and speed is shown on the Configuration page, the printer recognizes the connection. Example: "100BaseFullDuplex". This is a feature for some of the older Phaser products. Some products also display the Ethernet cable or network connection is not available on the Control Panel status screen.
 - a. If the Network Speed/Type is Disconnected, the printer is not recognizing the network card, or the printer is not detecting the cable or PWS.
 - b. Print the Configuration Page and check the Network Speed/Type. If still showing Disconnected, reseal the ESS Board and reprint the Configuration page.
 - c. If it still shows Disconnected, replace the ESS Board, REP 18.1.98.
4. Check TCP/IP settings and verify that "LPR and Appsocket Port 9100" are both enabled
5. Set TCP/IP configuration settings to match the first (original) configuration page printed.

GP 15 Deleted

GP 16 Separate System Modules

Use this procedure to remove optional modules from the printer.

Description

Most optional module service procedures require separation of the module from the printer.

WARNING

Switch off the electricity to the machine. Disconnect the power cord from the customer supply while performing tasks that do not need electricity. Electricity can cause death or injury. Moving parts can cause injury.

CAUTION

Always move the printer separately from the optional trays unless mounted on the option stand.

1. Clear the media path and output trays.
2. Refer to Figure 1 to locate and remove the Optional Feeder retaining screws before separating the printer and optional trays.

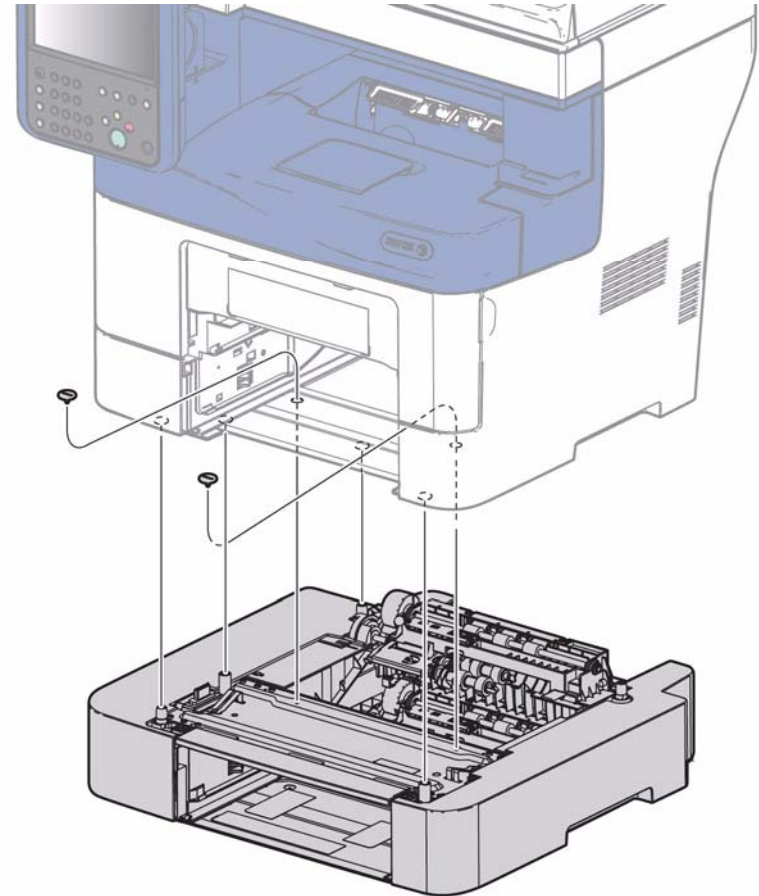

s3655-034

Figure 1 Separate the Optional Feeder from the printer

3. Lift the module to clear the locator bosses.
4. Place the module on a suitable work surface to avoid damage.
5. Check the position of the option connector before reassembly.

GP 17 External Fax Line Test

When the customer reports a fax issue sometimes it is very difficult to determine if the problem is with the customer's phone line or the Xerox machine.

The preferred method of verifying the phone line functionality is to use the Modem saver device part number 600T2133 to ensure the fax line is wired correctly and to use the Analog hand set part number 600T1937 or customer's analog phone to place calls on the line. Be sure that both local and long distance calls can be placed and the line quality is clear, no static.

Use Handset:

- Can it dial externally on the line?
- Can it receive a call on the line?
- Evaluate Line quality. Check Line for unwanted beeps, or noise.

Use Breakout Box to measure voltages (Use the machine chassis as ground). Refer to Fax 101 training for Breakout Box usage instruction:

- Check ground continuity .
- Line Voltage -20 to -50 VDC?
- Loop Current 15 to 95 mA DC?
- Ring Signal 50 to 90 VAC?
- Check Ring-Ground and Tip-Ground <1VAC

If a line quality issue or incorrect voltage is found then the customer will need to resolve these problems.

GP 18 Printing Reports

Purpose

To list reports available from the printer's Control Panel, refer to GP 3.

- Configuration Report
- PCL Font List
- PostScript Font List

Configuration Report

The Configuration Report lists the current state of system configuration parameters including installed options and network settings.

PCL Font List

This report provides a list of the installed PCL fonts.

PostScript Font List

This report provides a list of the installed PostScript fonts.

Procedure

Reports are printed from the Control Panel, CWIS, or if configured, automatically following certain events. From the Control Panel

NOTE: *It is not necessary to enter SA mode (log in) in order to perform this procedure.*

- Press the **Machine Status** button.
- Select **Machine Information** tab.
- Select **Information Pages...**
- Select the desired report and press **Print** button.

GP 19 Intermittent or Noise Problem

Purpose

The purpose of this RAP is to provide guidance for resolving an intermittent or noise problem. This is not an exact procedure, but a set of recommended actions that use the resources of the service manual to help locate the cause of an intermittent or noise problem.

Procedure

1. Check the service log. Recent service actions may provide information about the problem. For example, a component that was recently replaced to correct another problem may be the cause of the new intermittent problem.
2. Noise problems may be due to improper installation. Check for packing materials that have not been removed. Check for loose or missing hardware.
3. Run the printer in a mode that vigorously exercises the function that is suspected. The printer may fail more frequently or may fail completely under these conditions. Look for signs of failure or abnormal operation.

An intermittent problem can usually be associated with a RAP, since when it does fail, it results in a fault code, a jam code, or some other observable symptom.

4. Using the RAP that is associated with the symptom of the intermittent problem, examine all of the components that are referenced in the RAP. Look for:
 - contamination, such as a feed roller that has a build up of dirt or toner
 - wear, such as gear teeth that are rounded or have excessive backlash
 - CRUs, even if they have not exceeded life counts
 - wires chafing against components of the machine, especially against moving components
 - misaligned, mis-adjusted, or incorrectly installed components
 - slow or slipping clutches; slow or binding solenoids
 - damaged components
 - excessive heat, or symptoms of excessive heat, such as the discoloration of a component
 - loose cables or wires
5. Using the RAP that is associated with the symptom of the intermittent problem, perform all of the adjustments for the components or functions that are referenced in the RAP. Check to ensure that the adjustment can be made and that there is an adequate range of adjustment, and that it can be set to or near the nominal value. Any abnormality that is observed may be an indication of the cause of the problem. For example, a component can be adjusted to the nominal value, but it is at the limit of the adjustment range. This is not normal and may be an indication of the cause of the problem.
6. Operate all of the components in the appropriate RAP that is associated with the symptom of the intermittent problem with Component Control. Observe the components for any symptoms of abnormal operation, such as a hesitation, or an unusual sound.
7. Check that the AC and DC power are within specification.
8. Get technical advice or assistance when it is appropriate. This will depend upon the situation and the established local procedures.
9. Examine the components that are not in the RAP, but are associated with the function that is failing. Look for:
 - contamination, such as a feed roller that has a build up of dirt or toner

- wear, such as gear teeth that are rounded or have excessive backlash
 - CRUs, even if they have not exceeded life counts
 - wires chafing against components of the machine, especially against moving components
 - misaligned, mis-adjusted, or incorrectly installed components
 - slow or slipping clutches; slow or binding solenoids
 - damaged components
 - excessive heat, or symptoms of excessive heat, such as the discoloration of a component
 - loose cables or wires
10. Perform the adjustments for the components that are not in the RAP, but are associated with the function that is failing. Refer to the BSDs. Check to ensure adjustment is possible, there is an adequate range of adjustment, and it can be set to or near the nominal value. Any abnormality that is observed may be an indication of the cause of the problem. For example, a component can be adjusted to the nominal value, but it is at the limit of the adjustment range. This is not normal and may be an indication of the cause of the problem
 11. Operate all of the components that are not in the RAP, but are associated with the function that is failing with Component Control. Observe the components for any symptoms of abnormal operation, such as a hesitation, or an unusual sound.
 12. Replace any components or consumables that are known to be a frequent cause of the problem. When doing this, consider the cost and time required. If the suspected item is inexpensive, can be installed quickly, and has a high probability of resolving the problem, then it is reasonable to replace it.
 13. Leave an accurate and detailed record of your actions in the service log. Describe what you have observed, what actions you took, and the recommended next steps.

GP 20 How to Safely Lift or Move Heavy Modules

Use this procedure when lifting or moving heavy modules.

Description

Most service procedures for optional feeder modules require separation of the printer and feeders. Feeder removal requires 2 people.

WARNING

Mandatory safety warning. This procedure must be performed by 2 people. The module is heavy.

CAUTION

Always move the printer separately from optional trays unless the optional stand is installed.

When removing heavy modules, observe the following:

1. Locate a suitable stable surface to support the module after removal.
2. The support surface height is between 750mm and 1000mm (30 inches and 39 inches).
3. Check there are no hazards or obstacles between the printer and support surface.

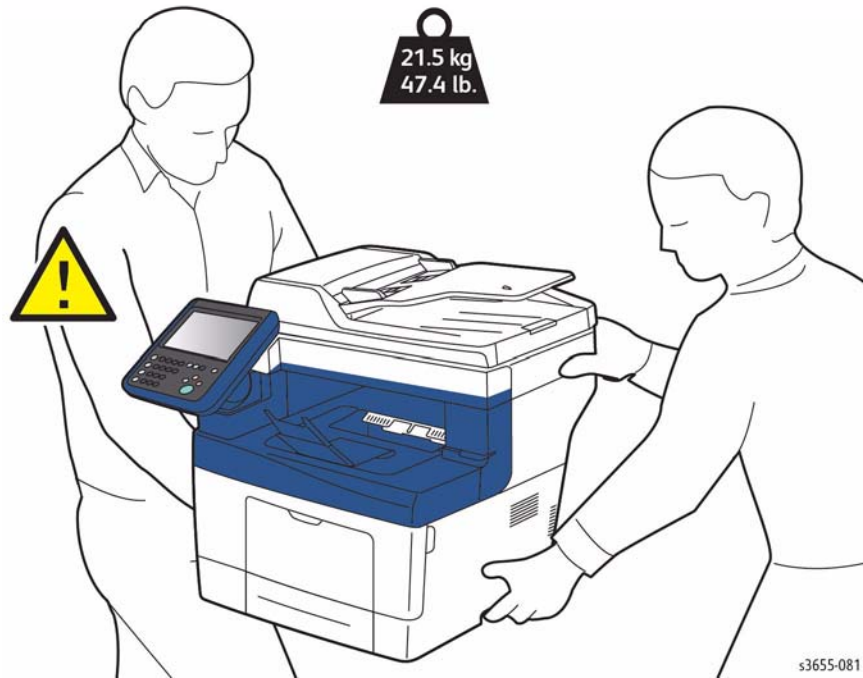

Figure 1 Printer lifting technique

GP 21 Machine Lubrication

Purpose

To give information on the use of lubricants.

Procedure

CAUTION

Only use lubricants as directed. Incorrect use of lubricants could seriously affect the performance of the machine.

Take the following precautions when performing machine lubrication:

- Wear disposable gloves.
- Only use lubricants that are specified in the procedure.
- Only lubricate parts as directed.
- Apply only the smallest amount of lubricant, sufficient to lubricate the parts. To prevent contamination, remove any surplus lubricant.
- Take great care not to contaminate other parts with the lubricant.

GP 22 Installation Space Requirements

WARNING

Do not work in a confined space. 1 m (39 inches) space is needed for safe working.

WARNING

USA and Canada. Do not install this machine in a hallway or exit route that does not have 1.12 m (44 inches) of space additional to the normal space requirements in front of the machine. To conform with fire regulations this additional 1.12 m (44 inches) of space is needed in front of the machine in hallway and exit route

Space Requirements

Figure 1 shows the required space needed to properly operate and service the machine.

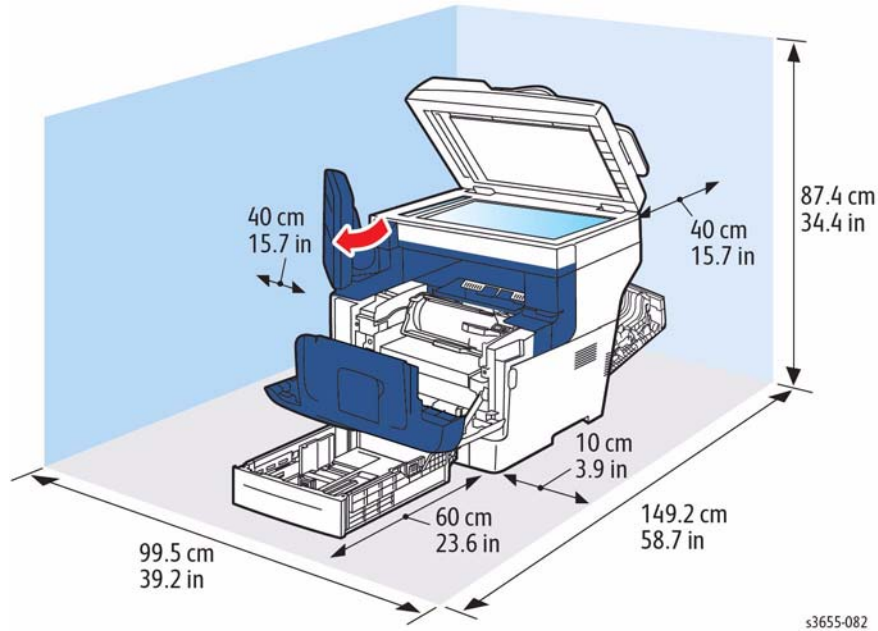

Figure 1 Minimum clearances

1. In order to function properly, the printer must be placed on a flat surface with the minimum clearances shown in Figure 1.
2. The printer must not be tipped or tilted more than 1% in either direction.

Dimensions

Figure 2 shows the product dimensions.

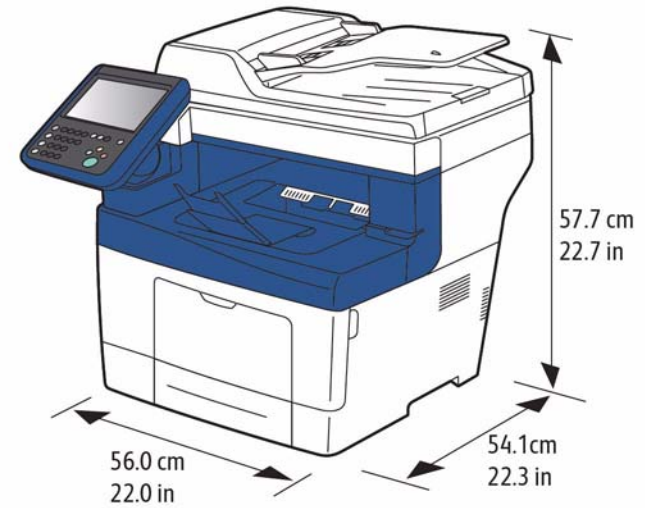

Figure 2 IOT Dimensions

s3655-083

s3655-082

GP 23 First Print Output Time

Purpose

First Print Output Time (FPOT) is the time from when the printer receives a PreStart command in Ready mode until the trailing edge of the first print is output, excluding a job with specific conditions, a job immediately after the recovery from Light Sleep Mode/Deep Sleep Mode, and a job immediately after Power On.

First Print Out Time for a single page on Letter/A4 size media from ready.

Table 1 First Print Output Time

Source	Simplex
Bypass Tray	8.0 seconds or less
Tray 1	8.0 seconds or less

GP 24 Restriction of Hazardous Substances (RoHS)

Purpose

To give information on the RoHS Directive.

The RoHS Directive restricts the use of certain hazardous substances in electrical and electronic equipment. It applies to equipment placed in the European Union (EU) market. The directive takes effect from 1st July 2006.

NOTE: *Currently these restrictions are only for the European Union (EU) market and some associated countries. For more information go to www.Xerox.com.*

The hazardous substances are:

- Lead (Pb)
- Mercury (Hg)
- Cadmium (Cd)
- Hexavalent Chromium (Cr 6+, Cr [VI])
- Polybrominated Diphenyl Ethers (PBDE's)
- Polybrominated Biphenyls (PBB's)

Identification of a RoHS Compliant Machine

Xerox maintains a central list of RoHS compliant printers. This general procedure is for information only. All current-model WorkCentre printers are RoHS compliant.

GP 25 Remote Control Panel

The Remote Control Panel feature enables users the ability to:

- Remotely view the local UI display graphics
- Operate both hard and soft buttons on the control panel

The Remote Control Panel on the remote user PC mimics the device control panel enabling the remote user to operate the device as though they were standing at the machine.

Operation

Feature enablement – The feature is defaulted off when delivered to the customer. The System Administrator is required to enable the feature to allow usage.

1. In the Centroware window, login as admin.
2. Select Support, then Remote Control Panel.
3. Under Configuration, select Edit.
4. Select Enable.

Feature access permissions – The SA is required to set the permissions of the feature for it to be usable. When Enable is selected, the permission levels are displayed.

- SA only – This setting will prevent any user including Service Engineer personal from using the feature.
- SA and Service Engineer – This setting allows only the SA or Service Engineer to use the feature by authenticating their respective user credentials.
- All users – This opens the feature to all users without the need to authenticate.

Remote Session – The Remote Control Panel session is initiated under Access. This feature allows only the Admin and Diagnostics User to interact with the machine's local Control Panel. Before starting the session, the remote user should determine if the session collaborative or blocked.

- **Collaborative** - This mode means that both the Remote Control Panel and the Local UI are active. This mode can be used by System administrator, help desk support, IT support, or training when the person at the machine and the remote user need to see how the other is operating the machine.
- **Local UI blocking** – Check the box by Block Local Control Panel (local user can only observe). This blocks the local panel when the remote session is initiated. This protects the machine during remote service procedures. When activated, the local user is notified by a message that the local panel hard and soft keys are not functional at this time.

Only one remote connection at a time is allowed. If a user attempts to initiate a session while another one is active, they will get a message indicating the system is busy and to try again later. This allows a service engineer to view the device remotely without concern that another non-Service Engineer session can also connect.

NOTE: If a general user has a remote session active and an SA initiates a session, the SA has a button that will disconnect the general user. This way the SA can take control when desired.

A secure connection is required to create a remote session. If SSL is not set on the machine, a message will appear stating that it must be set. The window for enabling SSL will be displayed and can be set so that the machine is configured to allow the remote session. After the machine reboots, the remote session can start.

Remote session indication – When the remote session is initiated, a temporary popup message is displayed on the Local UI alerting any local users that there is a remote user online. A status message is then indicated in the status region and soft login button. The soft login button region is meant to describe the user roles. Authenticated users, including CSEs, are displayed. These remain persistent until the session is closed. A local Service Engineer will know whether the device is being used.

Remote Session Operation - When the Remote Control Panel is opened, the remote user will see a mimic of the local UI.

- The soft and hard buttons from the machine control panel are displayed on the Remote Control Panel. The hard buttons are located in slightly different locations, but are labeled and function the same as on the local control panel.
- Operation of all the machine features is the same on the Remote Control Panel as at the local control panel and UI.

NOTE: If the browser magnification is set to 75%, then the viewing window will be smaller than the control panel and the touch screen will be truncated. Conversely, if the browser magnification is set to 125%, the viewing window is larger than the remote control panel. The entire control panel is visible but there will be large grey areas around the panel.

Service Access - The System Administrator has access to the machine within the customer firewall. The service engineer must be invited inside the firewall.

- The procedure for the customer to invite the service engineer to remotely access the machine is OPCO dependent. Contact your OPCO for instructions on how to engage the customer.
- After the customer has given the service engineer a portal through their firewall, the service engineer can connect to the machine.

Only the service engineer should have the diagnostic User ID and Password. Only the Service Engineer can launch a diagnostics session from the remote UI.

NOTE: If the device is in service mode when a remote session is initiated, the session will only connect if logged in as diag in CentreWare. This prevents non-service engineers from connecting into the device while it is being serviced.

1. Connect to the printer via CentreWare IS.
2. Login to Centerware
 - User ID - **diag**
 - Password - **3424**
3. Select Support, then select Remote Control Panel.
4. If required, check **Block Local Control Panel** (user can only observe).
5. Select **Open Remote Control Panel**.

NOTE: Only one Remote Control session at a time is allowed. If a remote session is in progress, a message (Remote Control Panel session is already active.) will appear. If approved by the SA, select Disconnect Current Session to enable access. If the message returns, the machine may need to be rebooted.

6. If the window "**The web site's certificate cannot be verified. Do you want to continue.**" appears, select **Yes**.

If the window "There is a problem with this website's security certificate." appears, select **Continue to this website (not recommended)**.

- To start Service Diagnostics, Select the Service Diagnostics button and login (6789).

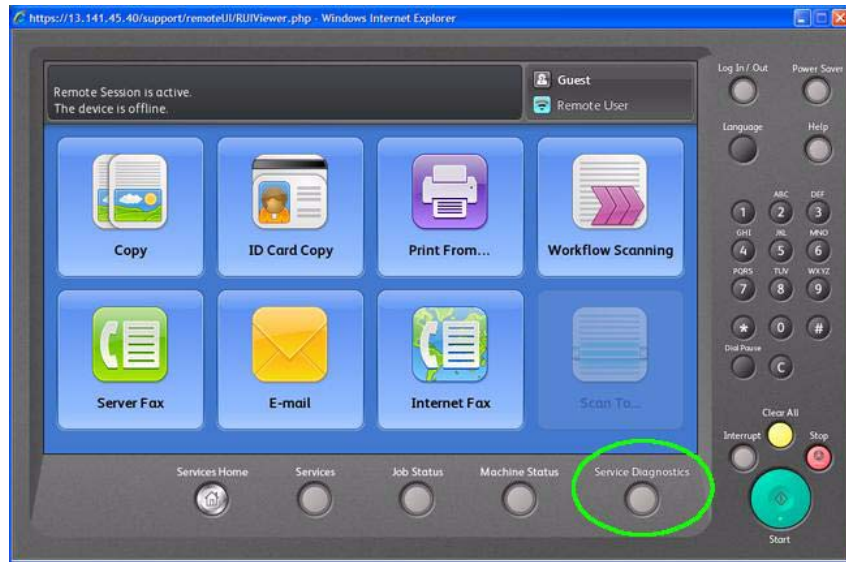

Figure 1 Diagnostic Access

Ending the session - A session can be terminated in several different ways. If in a diagnostic session, remember to perform Call Closeout before ending the session.

NOTE: If the session is terminated before performing Call Closeout, it may not be possible to reestablish the Remote Control Panel session. If, when you attempt to reconnect to the machine an error message comes up that indicates a problem with initiating the session for some reason, either Call Closeout will have to be done at the printer, or power will have to be cycled before the session can be reestablished and/or returned to Customer operating mode.

- Remote user closes the Remote Control Panel window.
- Machine reboots.
- Unplug the internet cable at the machine.
- Customer host that invited the service access closes their browser.
- System Timers - The session will be terminated if the system timers time out.

GP 26 Media Specifications

The media trays accommodate most sizes and types of paper or other specialty media. Print the Paper Tips page for a list of supported media.

Media that May Damage to the Printer

The printer can use a variety of media for print jobs. However, some media can cause poor output quality, increased jams, or damage. Unacceptable media includes:

- Envelope performance can be improved by installing an "envelope fuser"
- Rough, plastic, or porous media
- Transparency
- Paper that has been stapled, folded, photocopied, or wrinkled
- Envelopes with windows, metal clasps, padding, or adhesives with release strips (see PL 7.1)
- CD labels
- Media that is less than 60 g/m2 or more than 216 g/m2

Media Storage Guidelines

If media handling problems are common, review these storage guidelines with the customer.

- Store media in dark, cool, relatively dry locations. Most media is susceptible to damage from ultraviolet (UV) and visible light. UV radiation, emitted by the sun and fluorescent bulbs, is particularly damaging to media. The intensity and length of exposure to visible light should be reduced as much as possible.
- Maintain constant temperatures and relative humidity
- Inside walls are drier than outside walls where moisture can collect.
- Store flat. Media should be stored on pallets, cartons, shelves, or in cabinets.
- Do not open sealed packages until needed. Leave media in the original packaging. For most commercial grades, the wrapper's inner lining protects the media.

Supported Media

For information about supported paper and other media, print the Paper Tips page:

- On the Control Panel, press the **System** button.
- Select **Information**, and then press the **OK** button.
- Select **Information Pages**, and then press the **OK** button.
- Select **Paper Tips**, and then press the **OK** button to print.

See also: Recommended Media List at www.xerox.com/paper

Tray Capacity

Table 1 lists input tray capacities.

Table 1 Tray Capacity

Media and Weight	Bypass Tray	Tray 1	Optional Trays	DADF Input
Standard Paper	150 Sheets	550 Sheets	550 Sheets	60 Sheets
Envelope	10	0	0	0
Weight	60-216 g/m2	60-216 g/m2	60-216 g/m2	50-125 g/m2 60-125 g/m2 duplex

GP 27 Environmental Data Environmental Specifications

Table 1 Environmental Specifications

Characteristic	Specifications	
	Operating	Storage
Temperature	15° to 32° C (41° to 86° F)	-20° to 40° C (-4° to 104° F)
Humidity	15% to 85% RH Non-Condensing	5% to 85% RH, non-condensing
Acoustic Noise	Operation	
Sound Pressure (Decibels)	74.8 dB	53.0 dB

Procedure to convert to METERED (Page Pack) supplies

- Record the machine serial number and the number of **Total Impressions**
- Call Field Engineering or your NTS and provide the information collected in step 1.
- You will be given a 6-character passcode.
- Login as Admin, and then press **Machine Status** on the Control Panel.
- Select the **Tools** tab. The Tools menu will be displayed.
On the left side of the screen are several buttons for the categories of features.
Within each category are **Groups** of features. Each **Group** contains one or more **Features**.
- Select the Device Settings category, then the Supplies group, then select **Enter Plan Conversion Code**.

NOTE: Enter the passcode within 500 page counts of when it was issued, or it will not be valid.

- Enter the passcode string provided in Step 3. If the passcode contains a special character, the level of software installed on the machine may not allow entry of this character because it is grayed out. Use the following procedure to enter the special character.
 - Log into Tools
 - In the Features column, select [General...]
 - Select [Custom Keyboard Button...]
 - The 3rd button on the bottom row is the customizable button
 - Select [Clear Text]

GP 28 Toner CRUM Conversion

Purpose

This procedure explains how to set the geographic differentiation code and Toner Cartridge type to the correct values.

Introduction

The WorkCentre 3655 is shipped with “worldwide neutral” Toner Cartridges installed at the factory. When the cartridges shipped with the printer are installed, the printer is set to worldwide neutral configuration. When the Toner Cartridge is replaced, the geographic differentiation code and Toner Cartridge type in NVM automatically change to the same settings as the replacement cartridge. Once these NVM are set, the toner configuration can only be changed with a CRUM conversion.

There are three types of toner: Metered, which is a single part number world wide, Sold toner that is specific to the DMO/XING market, and Sold toner that is specific to NA/XE market. If a toner cartridge of the wrong type (i.e., a “sold” cartridge in a “metered” configured machine) is installed, it will generate a fault code and/or a message indicating toner incompatibility.

If the problem occurs after several toner replacements, the customer may have received the wrong toner in a consumables order; either because the wrong part number was ordered, or the shipment did not match the order. Resolution in this case is simple; the customer should exchange the toner for the correct part.

If the wrong toner was installed at the first toner replacement after install, or if the configuration NVM have changed due to software or NVM corruption, perform the following procedure:

Procedure to convert to SOLD (Non-Page Pack) supplies

- Record the machine serial number and the number of **Total Impressions**
- Call Field Engineering or your NTS and provide the information collected in step 1.
- You will be given a 6-character passcode.
- Login as Admin, and then press **Machine Status** on the Control Panel.
- Select the **Tools** tab. The Tools menu will be displayed.
On the left side of the screen are several buttons for the categories of features.
Within each category are **Groups** of features. Each **Group** contains one or more **Features**.
- Select the **Device Settings** category, then the **Supplies** group, then select **Enter Supplies Activation Code**.

NOTE: Enter the passcode within 500 page counts of when it was issued, or it will not be valid.

- Enter the passcode string provided in Step 3. If the passcode contains a special character, the level of software installed on the machine may not allow entry of this character because it is grayed out. Use the following procedure to enter the special character.
 - Log into Tools
 - In the Features column, select [General...]
 - Select [Custom Keyboard Button...]
 - The 3rd button on the bottom row is the customizable button
 - Select [Clear Text]

- f. Select [Shift]
 - g. Select the special character contained in the passcode
 - h. Select [Save]
 - i. Log out of Tools
8. The Geographic Differentiation Code and Toner Cartridge Type will be reset to the values of the customer's agreed-to supplies plan.

Procedure (Page Pack)

- 1. Before a 500 page count is reached, a PIN number must be entered, otherwise the machine will not operate after the 500 page limit.
- 2. If a bad PIN is entered 3 times consecutively, you must wait 24 hours before a good PIN can be entered.

dC104 Usage Counters

Purpose

To display the various usage counters.

Procedure

1. Enter Service Diagnostics, GP 1.
2. Select the Service Info tab.
3. Select dC104 Usage Counters.
4. Select the relevant counters from the pull down menu.
5. Select Close to exit the routine.
6. Select Call Closeout to exit Service Diagnostics.

dC108 Software Version

Purpose

To identify the version of the installed software on all major modules.

Procedure

1. Enter Service Diagnostics, GP 1.
2. Select the Service Info tab.
3. Select dC108 Software Versions.
The dC108 Software Versions screen will display the software and version numbers installed on the machine.
4. Select Close to exit the routine.
5. Select Call Closeout to exit Service Diagnostics.

dC120 Fault Counters

Purpose

To view the faults raised by the machine. Fault Counters records the number of occurrences of a fault, allows the counters to be sorted by occurrences and allows a specific fault to be found by chain.

Procedure

1. Enter Service Diagnostics, GP 1.
2. Select dC120 Fault Counters.

NOTE: *There will be a delay while the machine retrieves the fault counter data.*

3. A list of faults that have occurred is displayed.
 - The list can be sorted by number of occurrences and to include zero occurrences. Selecting these options will resort the list upon selection.

NOTE: *When selecting zero occurrences there may be a delay as the list is reconfigured.*

- The list can be sorted by chain.
 - a. Select the chain field.
 - b. Enter a 3-digit chain number on the numeric keypad.
 - c. Select Find.
4. Select Close to exit the routine.
 5. Select Call Closeout to exit Service Diagnostics.

dC122 Fault History

Purpose

To view faults in chronological order and more detail than is shown in dC120 Fault Counters.

Procedure

1. Enter Service Diagnostics, GP 1.
2. Select dC122 Fault History.
3. The dC122 Fault History screen is displayed with the last 40 faults shown in chronological order. The most recent fault is at the top of the list.
4. To observe the details of the fault, select the fault and select Details on the pop-up window. Select Close to return to the fault table.
5. Select Close to exit the routine.
6. Select Call Closeout to exit Service Diagnostics.

dC131 NVM Read/Write

Purpose

To review and modify values stored in NVM.

Description

NVM parameters are identified by an NVMMID in the form XXX-XXX. Refer to Table 1 for NVM parameters.

Procedure

1. Enter Service Diagnostics, GP 1.
2. Select the Adjustments tab.
3. Select dC131 NVM Read/Write.
4. Select the appropriate NVMMID.
5. View or edit the NVM value as necessary.
6. When the values have been changed, cycle system power to verify changes made to NVM.

Table 1 NVM Parameter Values

NVMMID	Name	Default	Minimum	Maximum
740-002	NVM Major	1	0	1
740-003	NVM Minor	5	0	5
740-004	NVM Patch	0	0	0
740-005	NVM Test	0	0	0
740-006	Factory Option Setting	0	0	255
740-007	IOT Config	0	0	255
740-014	Enable Duplex	1	0	1
740-015	hwerr_history_0_0	0	0	255
740-016	hwerr_history_0_1	0	0	255
740-017	hwerr_history_0_2	0	0	255
740-018	hwerr_history_0_3	0	0	255
740-019	hwerr_history_0_4	0	0	255
740-020	hwerr_history_0_5	0	0	255
740-021	hwerr_history_0_6	0	0	255
740-022	hwerr_history_0_7	0	0	255
740-023	hwerr_history_1_0	0	0	255
740-024	hwerr_history_1_1	0	0	255
740-025	hwerr_history_1_2	0	0	255
740-026	hwerr_history_1_3	0	0	255
740-027	hwerr_history_1_4	0	0	255
740-028	hwerr_history_1_5	0	0	255
740-029	hwerr_history_1_6	0	0	255
740-030	hwerr_history_1_7	0	0	255
740-031	hwerr_history_2_0	0	0	255

Table 1 NVM Parameter Values

NVMMID	Name	Default	Minimum	Maximum
740-032	hwerr_history_2_1	0	0	255
740-033	hwerr_history_2_2	0	0	255
740-034	hwerr_history_2_3	0	0	255
740-035	hwerr_history_2_4	0	0	255
740-036	hwerr_history_2_5	0	0	255
740-037	hwerr_history_2_6	0	0	255
740-038	hwerr_history_2_7	0	0	255
740-500	NV Limitation	0	0	255
742-008	side_reg_factory_0_0	-6	-32	32
742-009	side_reg_factory_0_1	-6	-32	32
742-010	side_reg_factory_0_2	-6	-32	32
742-011	side_reg_factory_0_3	-6	-32	32
742-012	side_reg_factory_0_4	-6	-32	32
742-013	side_reg_factory_1_0	-3	-32	32
742-014	side_reg_factory_1_1	-3	-32	32
742-015	side_reg_factory_1_2	-3	-32	32
742-016	side_reg_factory_1_3	-3	-32	32
742-017	side_reg_factory_1_4	-3	-32	32
742-516	Jam History	0	0	255
744-009	FusingInspectionMode	1	0	255
744-050	heat_temp_print_user_0_0	0	-9	9
744-051	heat_temp_print_user_0_1	0	-9	9
744-052	heat_temp_print_user_0_2	0	-9	9
744-053	heat_temp_print_user_0_3	0	-9	9
744-054	heat_temp_print_user_0_4	0	-9	9
744-055	heat_temp_print_user_0_5	0	-9	9
744-056	heat_temp_print_user_0_6	0	-9	9
744-057	heat_temp_print_user_0_7	0	-9	9
744-058	heat_temp_print_user_0_8	0	-9	9
744-059	heat_temp_print_user_0_9	0	-9	9
744-060	heat_temp_print_user_0_10	0	-9	9
744-061	heat_temp_print_user_0_11	0	-9	9
744-062	heat_temp_print_user_1_0	0	-9	9
744-063	heat_temp_print_user_1_1	0	-9	9
744-064	heat_temp_print_user_1_2	0	-9	9
744-065	heat_temp_print_user_1_3	0	-9	9
744-066	heat_temp_print_user_1_4	0	-9	9
744-067	heat_temp_print_user_1_5	0	-9	9
744-068	heat_temp_print_user_1_6	0	-9	9
744-069	heat_temp_print_user_1_7	0	-9	9
744-070	heat_temp_print_user_1_8	0	-9	9

Table 1 NVM Parameter Values

NVMID	Name	Default	Minimum	Maximum
744-071	heat_temp_print_user_1_9	0	-9	9
744-072	heat_temp_print_user_1_10	0	-9	9
744-073	heat_temp_print_user_1_11	0	-9	9
744-074	heat_temp_print_user_2_0	0	-9	9
744-075	heat_temp_print_user_2_1	0	-9	9
744-076	heat_temp_print_user_2_2	0	-9	9
744-077	heat_temp_print_user_2_3	0	-9	9
744-078	heat_temp_print_user_2_4	0	-9	9
744-079	heat_temp_print_user_2_5	0	-9	9
744-080	heat_temp_print_user_2_6	0	-9	9
744-081	heat_temp_print_user_2_7	0	-9	9
744-082	heat_temp_print_user_2_8	0	-9	9
744-083	heat_temp_print_user_2_9	0	-9	9
744-084	heat_temp_print_user_2_10	0	-9	9
744-106	Fuser Print Volume Near	180,000	0	4294967295
744-110	Fuser Print Volume End	200,000	0	4294967295
744-118	Lamp On Time Near	750,000	0	4294967295
744-122	Lamp On Time End	780,000	0	4294967295
746-020	cmd_tnr_refresh	0	0	255
746-021	cmd_btr_ppm_dn	0	0	1
746-023	Initial Install CRU	0	0	1
746-108	cmd_deve_refresh	0	0	1
746-201	Belt Print Volume Near	180,000	0	4294967295
746-205	Belt Print Volume End	200,000	0	4294967295
746-500	UserCorrectBTRPlainL	6	1	16
746-501	UserCorrectBTRPlainH	6	1	16
746-502	UserCorrectBTRThicker	6	1	16
746-503	UserCorrectBTRRecycled	6	1	16
746-504	UserCorrectBTRHeavierL	6	1	16
746-505	UserCorrectBTRHeavierH	6	1	16
746-506	UserCorrectBTRLabelL	6	1	16
746-507	UserCorrectBTRLabelH	6	1	16
746-508	UserCorrectBTRReserved	6	1	16
746-509	UserCorrectBTREnvelope	6	1	16
746-510	UserCorrectBTRPostcard	6	1	16
746-526	HighlandMode	0	0	7
746-531	Deve CRU Pixel counter	0	0	4294967295
746-535	Deve CRU Drum Motor round time	0	0	4294967295
752-006	ATC Barcode	85	0	255
752-026	cnt_empty_chk_sw	1	0	255
752-570	Toner Cartridge PV counter	0	0	4294967295

Table 1 NVM Parameter Values

NVMID	Name	Default	Minimum	Maximum
766-003	Enable CRUM ID Check	0	0	255
766-046	Toner OEM Code	130	0	255
766-050	XERO OEM Code	130	0	255

dC132 Serial Number Restore

Purpose

Serial number data is stored at three locations:

- MCU Board
- ESS Board
- IIT Control Board

This procedure is used to restore serial number data integrity in the event serial number data becomes corrupt.

It is not necessary to run this procedure if a single board is replaced; if these boards are replaced one-at-a-time, the printer automatically synchronizes the data on the new board. It is only necessary to perform this procedure if multiple board replacement has resulted in the loss or corruption of serial number data.

At power On:

1. The Controller reads the device serial number from IOT
2. The Controller reads the device serial number from IIT
3. The Controller compares IOT & IIT Serial numbers to it's own saved serial number

If the IOT & IIT Serial numbers match, but the controller doesn't match, the Controller serial number is synched with the other boards. If any two of the three match, the third is updated to match (if necessary). If none of the three match, a serial sync fault is raised.

Initial Action

Check fault history for communications faults. Intra-board communications faults can prevent serial number synchronization and must be addressed before proceeding.

Procedure

Part 1 - Request serial number passcode.

NOTE: It may take up to 24 hours to receive a password from ACAST.

1. Enter Service Diagnostics, GP 1.
2. Select the Maintenance tab.
3. Select dC132.

CAUTION

After the Unique Machine Identifier is generated, **DO NOT** touch the Generate New Identifier Code button again, as this invalidates the provided passcode.

4. Select Generate New Identifier Code. Record the Unique Machine Identifier

NOTE: Follow all instructions included in the form. You must complete the form, print it, obtain required signatures and data, then scan it.

5. Use the attached ACAST Serial Number Reinitialization Request Form.
6. Read instructions and warning in the form very carefully.
7. Note that there is a cost for this service.
8. Fill all the information. Print the completed form. Have your budget center manager sign the form. If any information is missing, we cannot perform the service.



9. Have National Technical Specialist (NTS, RSE or FE) forward a copy of service log and proof of the location of the machine to acst01@xerox.com. This information must indicate machine location, customer name, and address.

Proof may be screen capture of NTS customer support database (account management database), FWSS, ICSS, DFM BT, VQMS, VALE, STPR, etc. The information on the proof must match information on the form.

10. Scan the completed form and email to acst01@xerox.com.

Part 2 - Restore serial number

CAUTION

DO NOT touch the **Generate Id** button, as this will invalidate the Password that will be provided.

1. Enter Service Diagnostics, GP 1.
2. Select the Maintenance tab.
3. Select Enter Passcode.
4. Enter the passcode received from ACAST and touch Enter.
5. Exit Service Diagnostics.
6. Cycle system power.

Serial numbers are now synchronized.

dC135 CRU/HFSI Status

Purpose

To view and reset counters for customer replacement units.

NOTE: dC135 is also available from the Maintenance tab.

Procedure

1. Enter service mode, GP 1.
2. Select dC135 CRU / HFSI. Current counts for the Fuser and Transfer Roller are listed.
3. To reset the CRU counter:
 - a. Select the item.
 - b. Select Reset Counter.
 - c. Select Reset to confirm.
4. Select Close to exit the routine.
5. Select Call Closeout to exit service mode.

dC140 Analog Monitor

Purpose

Monitor or adjust specific analog components. The nominal range and, when monitoring is active, the current value is displayed. Values are updated at least every second to allow the component state to be monitored. Refer to Table 1 and Table 2.

Procedure

1. Enter service mode, GP 1.
2. Select the Diagnostics tab.
3. Select dC140 Analog Monitor.
4. Scroll to display the available analog components.
5. Select the required item from the table.
6. A popup menu will be displayed, select start to confirm.
 - The table will display a status against the selected component.
 - In service mode the components are not active so the value will not change.
 - To check the component either manipulate the component manually or make a note of the value, exit Analog Monitor go to dC330 Component Control, to run the component and return to dC140 Analog Monitor.
 - Multiple components may be selected.
 - To stop monitoring select the required component and select stop.
 - Selecting Close will stop monitoring all components.
7. Select Close to return to the Diagnostic Routine window.
8. Select Call Closeout to exit service mode.

Table 1 Analog Component Input Values

ID	Component Name	Range	Comments
010.200	Fusing Main STS Sensor	0 - 1023	Monitor only
010.201	Fusing Sub STS Sensor	0 - 1023	Monitor only
046.200	BTR Current Monitor	0 - 1023	Monitor only
091.200	Environment Sensor Temperature	0 - 1023	Monitor only
091.201	Environment Sensor Humidity	0 - 255	Monitor only
092.200	ATC Sensor	0 - 1023	Monitor only

Table 2 Analog Component Output Values

ID	Component Name	Range	Comments
46 - 001	DA_VREF	0 - 255	Writable
46 - 002	DA_TR+	0 - 255	Writable
46 - 003	DA_TR-	0 - 255	Writable
46 - 004	DA_DBAC	0 - 255	Writable
46 - 005	DA_DBDC	0 - 255	Writable
46 - 006	DA_CR	0 - 255	Writable
93 - 001	DA_DISP_MOT	0 - 255	Writable

dC188 Service Mode Exit

Purpose

To exit Service Diagnostics.

Procedure

1. Enter service mode, GP 1.
2. Select Call Closeout to exit service mode.

dC301 NVM Initialization

General

The purpose of the NVM initialization routine is to reset the values of all applicable NVM parameters to default. There are three domains and three types of initialization.

The three machine domains are:

- Copier
- Network Controller
- Fax

***NOTE:** The network controller does not contain any NVM values accessible. Therefore, no NVM initialization procedures are for the network controller are provided here.*

The three types of initialization are:

- **User data** That data which defines the way the customer prefers that the equipment operates (i.e. customer preference, SA/KO settings, configuration).
- **System data** That data which defines the way the equipment operates in relation to its environment (i.e. machine variables).
- **All data:** That additional data (on top of System and User data) which may be initialized without significantly impacting the machines operation. (i.e. machine variables, SA/KO settings, Fault log).

Copier NVM Initialization

Purpose

To reset specific or all variable NVM (with the exception of protected NVM for which a password is required) to default values.

***NOTE:** Initialization does not affect the billing counter and accounting.*

Procedure

1. Save the NVM to disk, refer to NVM Save and Restore, dC361.
2. Enter service mode, GP 1.
3. Select the Adjustments tab.
4. Select dC301 NVM Initialization.
5. Select Copier.
6. Select the sub-domain. Refer to Table 1 for the functions in each sub domain.
 - Copy Controller
 - Scanner
 - Print Engine
 - Finisher
7. Select the NVM data to reset. Refer to Table 1 for the functions that are reset to default.
 - User
 - System
 - All
8. Select Initialize, when the pop-up window appears confirm the request. A message will be displayed to indicate successful completion.
9. Exit dC301 NVM initialization.

10. Select Call Closeout to exit service mode.
11. Reboot the machine for the changes to take effect.

Fax NVM initialization

Purpose

To return to default the Fax NVM settings that are stored on the Fax Board.

Procedure

1. Save the NVM to disk, refer to NVM Save and Restore, dC361.
2. Enter service mode, GP 1.
3. Select the Adjustments tab.
4. Select dC301 NVM Initialization.
5. Select Fax.
6. Select the NVM data to reset. Refer to Table 2 for the functions that are reset to default.
 - User
 - System
 - All

NOTE: Deletion of all data.

7. Select Initialize when the pop-up window appears confirm the request.
8. A message is displayed to indicate successful completion.
9. Exit dC301 NVM Initialization.
10. Select Call Closeout to exit diagnostics.
11. Cycle system power for the changes to take effect.

Table 1 Copier NVM

Sub-Domain	NVM Initialization Type	User Data NVM	System Data NVM	All Data NVM
Copy Controller	All	N	N	N
	Billing Counter	N	N	N
	System Usage Counter			Y
	Fault Counter (1)			Y
	Diagnostic Counter (1)			Y
	SA / KO Setting	Y		Y
	Fault Log			Y
	Configuration			Y
	Diagnostics			Y
	Debug			Y
	Machine Variable		Y	Y
	Machine Variable Xero		Y	Y
	Machine Variable Registration		Y	Y
	Machine Variable Paper Path		Y	Y
	Machine Variable DADH		Y	Y
	Machine Variable Platen		Y	Y
	Auditron	Y		Y
	ESS	N	N	N
	Crash Recovery Type			Y
	Completed Job Log			Y
	Controlled Access	N	N	N
	Machine Speed, Market Region			
	JBA Database	Y		Y
	JBA Configuration	Y		Y
	Auditron Configuration	Y		Y
	Xerox Standard Accounting	N	N	N
HFSI Counter	N	N	N	
Scanner	NVM Machine Variable		Y	Y
	SA / KO Setting	Y		Y
	Configuration			Y
Printer	NVM Machine Variable		Y	Y
	SA / KO Setting	Y		Y
	Configuration			Y

(1) These counters are reset using the Reset Counters option provided in the Call Closeout feature.

Table 2 Fax NVM

NVM Initialization Type	User Data NVM	System Data NVM	All Data NVM
Controlled Access (2)			Y
Completed Job Log	Y		(Y)
Auditron	Y		(Y)
Configuration	Y	Y	(Y)
SA / KO Setting	Y		(Y)

(2) The Fax functionality for the NVM All Data Initialization will result in all of the NVM data being deleted, which is why the other categories are shown in brackets.

UI Panel Diagnostics

Purpose

To exercise the Control Panel and Touch Screen to verify functionality

Procedure

1. On the Control Panel (*not from Diagnostics*)
2. Press and hold the * # C keys on the Control Panel in sequence.
3. Release the three keys.

The UI will display Panel Diagnostics with a menu to test the Control Panel UI.

Panel Diagnostics

1. **LCD Pixel Test**
 1. Red Pixel Test
 2. Green Pixel Test
 3. Blue Pixel Test
 4. All White Pixel Test
 5. All Black Pixel Test
 0. Back
2. **Touch Panel Calibration**
3. **Touch Panel Test**
 1. Start Touch Panel Test
 2. Start Touch Panel Key Test
 0. Back
4. **Button Test**
5. **Display Vertical Test**
 1. Red Gray Scale
 2. Green Gray Scale
 3. Blue Gray Scale
 4. Display 3 Vertical
 5. Display 33 Vertical
 6. Display 50 Vertical
 7. Display 100 Vertical
 8. Display 200 Vertical
 0. Back
6. **LED Test**
0. **Exit**

dC312 Network Echo Test

Purpose

To check network connectivity.

Procedure

1. Enter Service Mode, GP 1.
2. Select the Diagnostics tab.
3. Select dC312 Network Echo Test.
4. Select the required protocol from TCP / IP, AppleTalk or Novel or IPX.
5. Select Start Test.

The status region at the top of the user interface will indicate that the test is in progress.

The status region will indicate the result of the test before returning to the previous display.

6. Select Close to exit the routine.
7. Select Call Closeout to exit Service Mode.

dC330 Component Control

Purpose

To display status of input components e.g. sensors, and energize output components e.g. motors, solenoids.

Description

Input and output component control codes are entered into the Component Control Table on the Control Panel, and then energized individually or in permitted groups.

NOTE: Test display names do not necessarily match part names used in this manual. Where possible, test descriptions identify the part as named in the manual.

Component codes are listed in these tables:

- Input Components
 - Table 1 Chain 5 Component Input Codes
 - Table 2 Chain 10 Component Input Codes
 - Table 3 Chain 40 Component Input Codes
 - Table 4 Chain 60 Component Input Codes
 - Table 5 Chain 70 Component Input Codes
- Output Components
 - Table 6 Chain 5 Component Output Codes
 - Table 7 Chain 10 Component Output Codes
 - Table 8 Chain 20 Fax Line 1 Component Output Codes
 - Table 9 Chain 20 Fax Line 2 Component Output Codes
 - Table 10 Chain 40 Component Output Codes
 - Table 11 Chain 60 Component Output Codes
 - Table 12 Chain 70 Component Output Codes
 - Table 13 Chain 90 Component Output Codes

Input Components

When the appropriate code is entered, component status appears on the Control Panel.

NOTE: The actual signal as measured with a service meter will not necessarily be the same as the logic state shown on the Control Panel, especially where the output is inverted. When testing components using these control codes, look for a change in state, not for a high or low.

The displayed status of the input component can be changed by causing the component status to change, e.g. operating a sensor with a sheet of paper.

Table 1 Chain 5 Component Input Codes

Chain-Link	Component Name	State	Comments
005.230	Feed Sensor	On / Off	
005.231	DADF Input Tray Sensor	On / Off	Media in DADF Input Tray
005.232	DADF Top Cover Sensor	On / Off	DADF Top Cover open
005.233	Stage Sensor	On / Off	
005.234	Legal Paper Sensor	On / Off	Legal media in DADF Tray

Table 2 Chain 10 Component Input Codes

Chain-Link	Component Name	State	Comments
010.200	Fusing Relay Enable	On / Off	

Table 3 Chain 40 Component Input Codes

Chain-Link	Component Name	State	Comments
041.300	Front Cover Interlock Switch	On / Off	
041.301	Rear Cover Interlock Switch	On / Off	
042.200	Rear Fan Fail	On / Off	Alarm signal
042.201	LVPS Fan Fail	On / Off	Alarm signal

Table 4 Chain 60 Component Input Codes

Chain-Link	Component Name	State	Comments
062.212	Home Position Sensor	On / Off	
062.300	Platen Cover Sensor	On / Off	

Table 5 Chain 70 Component Input Codes

Chain-Link	Component Name	State	Comments
071.100	Bypass Tray No Paper Sensor	On / Off	
071.101	Tray1 No Paper Sensor	On / Off	
071.102	Registration Sensor	On / Off	
071.103	Exit Sensor	On / Off	
071.104	Paper Size Sensor1 Switch	On / Off	
071.105	Paper Size Sensor2 Switch	On / Off	
071.106	Paper Size Sensor3 Switch	On / Off	
071.107	Option Feeder1 Size Sensor0 Switch	On / Off	
071.108	Option Feeder1 Size Sensor1 Switch	On / Off	
071.109	Option Feeder1 Size Sensor2 Switch	On / Off	
071.110	Option Feeder2 Size Sensor0 Switch	On / Off	
071.111	Option Feeder2 Size Sensor1 Switch	On / Off	
071.112	Option Feeder2 Size Sensor2 Switch	On / Off	
071.113	Option Feeder3 Size Sensor0 Switch	On / Off	
071.114	Option Feeder3 Size Sensor1 Switch	On / Off	
071.115	Option Feeder3 Size Sensor2 Switch	On / Off	
071.116	Option Feeder1 No Paper Sensor	On / Off	
071.117	Option Feeder2 No Paper Sensor	On / Off	
071.118	Option Feeder3 No Paper Sensor	On / Off	
071.119	Option Feeder1 Path Sensor	On / Off	
071.120	Option Feeder2 Path Sensor	On / Off	
071.121	Option Feeder3 Path Sensor	On / Off	
071.122	Full Stack Sensor	On / Off	
071.200	Option Feeder1 Motor Fail	On / Off	Alarm signal

Table 5 Chain 70 Component Input Codes

Chain-Link	Component Name	State	Comments
071.201	Option Feeder2 Motor Fail	On / Off	Alarm signal
071.202	Option Feeder3 Motor Fail	On / Off	Alarm signal

Output Components

When the appropriate code is entered, the component is activated and its status appears on the Control Panel. **Note:**

Before running motors or clutches, +24vdc must be enabled using 041-001

Table 6 Chain 5 Component Output Codes

Chain-Link	Component Name	State	Comments
005.091	Pick Motor	On / Off	Forward
005.092	Pick Motor	On / Off	Reverse
005.093	Feed Motor	On / Off	Forward
005.094	Feed Motor	On / Off	Reverse

Table 7 Chain 10 Component Output Codes

Chain-Link	Component Name	State	Comments
010.001	Fusing Relay	On / Off	

Table 8 Chain 20 Fax Line 1 Component Output Codes

Chain-Link	Component Name	State	Comments
020.010	Single Tone 0hz Line 1	On / Off	
020.011	Single Tone 400hz Line 1	On / Off	
020.012	Single Tone 1100hz Line 1	On / Off	
020.013	Single Tone 1300hz Line 1	On / Off	
020.014	Single Tone 1650hz Line 1	On / Off	
020.015	Single Tone 1850hz Line 1	On / Off	
020.016	Single Tone 2100hz Line 1	On / Off	
020.017	ANSAM Line 1	On / Off	
020.018	CI Line 1	On / Off	
020.020	DTMF # Line 1	On / Off	
020.021	DTMF * Line 1	On / Off	
020.022	DTMF 0 Line 1	On / Off	
020.023	DTMF 1 Line 1	On / Off	
020.024	DTMF 2 Line 1	On / Off	
020.025	DTMF 3 Line 1	On / Off	
020.026	DTMF 4 Line 1	On / Off	
020.027	DTMF 5 Line 1	On / Off	
020.028	DTMF 6 Line 1	On / Off	
020.029	DTMF 7 Line 1	On / Off	
020.030	DTMF 8 Line 1	On / Off	

Table 8 Chain 20 Fax Line 1 Component Output Codes

Chain-Link	Component Name	State	Comments
020.031	DTMF 9 Line 1	On / Off	
020.032	DTMF A Line 1	On / Off	
020.033	DTMF B Line 1	On / Off	
020.034	DTMF C Line 1	On / Off	
020.035	DTMF D Line 1	On / Off	
020.040	V.21 300bps Line 1	On / Off	
020.041	V.27ter 2400bps Line 1	On / Off	
020.042	V.27ter 4800bps Line 1	On / Off	
020.043	V.29 7200bps Line 1	On / Off	
020.044	V.29 9600bps Line 1	On / Off	
020.045	V.17 7200bps Line 1	On / Off	
020.046	V.17 9600bps Line 1	On / Off	
020.047	V.17 12000bps Line 1	On / Off	
020.048	V.17 14400bps Line 1	On / Off	
020.049	V.34 2400bps Line 1	On / Off	
020.050	V.34 4800bps Line 1	On / Off	
020.051	V.34 7200bps Line 1	On / Off	
020.052	V.34 9600bps Line 1	On / Off	
020.053	V.34 12000bps Line 1	On / Off	
020.054	V.34 14400bps Line 1	On / Off	
020.055	V.34 16800bps Line 1	On / Off	
020.056	V.34 19200bps Line 1	On / Off	
020.057	V.34 21600bps Line 1	On / Off	
020.058	V.34 24000bps Line 1	On / Off	
020.059	V.34 26400bps Line 1	On / Off	
020.060	V.34 28800bps Line 1	On / Off	
020.061	V.34 31200bps Line 1	On / Off	
020.062	V.34 33600bps Line 1	On / Off	

Table 9 Chain 20 Fax Line 2 Component Output Codes

Chain-Link	Component Name	State	Comments
020.090	DTMF # Line 2	On / Off	
020.091	DTMF * Line 2	On / Off	
020.092	DTMF 0 Line 2	On / Off	
020.093	DTMF 1 Line 2	On / Off	
020.094	DTMF 2 Line 2	On / Off	
020.095	DTMF 3 Line 2	On / Off	
020.096	DTMF 4 Line 2	On / Off	
020.097	DTMF 5 Line 2	On / Off	
020.098	DTMF 6 Line 2	On / Off	
020.099	DTMF 7 Line 2	On / Off	
020.100	DTMF 8 Line 2	On / Off	
020.101	DTMF 9 Line 2	On / Off	
020.102	DTMF A Line 2	On / Off	
020.103	DTMF B Line 2	On / Off	
020.104	DTMF C Line 2	On / Off	
020.105	DTMF D Line 2	On / Off	
020.110	V.21 300bps Line 2	On / Off	
020.111	V.27ter 2400bps Line 2	On / Off	
020.112	V.27ter 4800bps Line 2	On / Off	
020.113	V.29 7200bps Line 2	On / Off	
020.114	V.29 9600bps Line 2	On / Off	
020.115	V.17 7200bps Line 2	On / Off	
020.116	V.17 9600bps Line 2	On / Off	
020.117	V.17 12000bps Line 2	On / Off	
020.118	V.17 14400bps Line 2	On / Off	
020.119	V.34 2400bps Line 2	On / Off	
020.120	V.34 4800bps Line 1	On / Off	
020.121	V.34 7200bps Line 1	On / Off	
020.122	V.34 9600bps Line 1	On / Off	
020.123	V.34 12000bps Line 1	On / Off	
020.124	V.34 14400bps Line 1	On / Off	
020.125	V.34 16800bps Line 1	On / Off	
020.126	V.34 19200bps Line 1	On / Off	
020.127	V.34 21600bps Line 1	On / Off	
020.128	V.34 24000bps Line 1	On / Off	
020.129	V.34 26400bps Line 1	On / Off	
020.130	V.34 28800bps Line 1	On / Off	
020.131	V.34 31200bps Line 1	On / Off	
020.132	V.34 33600bps Line 1	On / Off	

Table 9 Chain 20 Fax Line 2 Component Output Codes

Chain-Link	Component Name	State	Comments
020.080	Single Tone 0hz Line 2	On / Off	
020.081	Single Tone 400hz Line 2	On / Off	
020.082	Single Tone 1100hz Line 2	On / Off	
020.083	Single Tone 1300hz Line 2	On / Off	
020.084	Single Tone 1650hz Line 2	On / Off	
020.085	Single Tone 1850hz Line 2	On / Off	
020.086	Single Tone 2100hz Line 2	On / Off	
020.087	ANSAM Line 2	On / Off	
020.088	CI Line 2	On / Off	

Table 10 Chain 40 Component Output Codes

Chain-Link	Component Name	State	Comments
041.001	Low Voltage Power Supply 24V	On / Off	
042.001	Rear Fan	On / Off	Normal speed
042.002	Rear Fan	On / Off	Half speed
042.003	LVPS Fan	On / Off	

Table 11 Chain 60 Component Output Codes

Chain-Link	Component Name	State	Comments
061.001	Laser Unit Motor	On / Off	
062.002	IIT Exposure Lamp	On / Off	
062.005	FB Motor	On / Off	Forward
062.006	FB motor	On / Off	Reverse

Table 12 Chain 70 Component Output Codes

Chain-Link	Component Name	State	Comments
071.001	Main Drive Assembly	On / Off	Normal speed
071.002	Main Drive Assembly	On / Off	Half speed
071.003	Main Drive Assembly	On / Off	Low speed
071.004	MSI Feed Solenoid	On / Off	Auto Off (300ms)
071.005	Tray1 Feed Clutch	On / Off	
071.006	Registration Clutch	On / Off	
071.007	Exit Clutch	On / Off	
071.008	Exit Invert Clutch	On / Off	
071.009	Option Feeder1 Motor	On / Off	Normal speed
071.010	Option Feeder1 Motor	On / Off	Half speed
071.011	Option Feeder1 Motor	On / Off	Low speed
071.012	Option Feeder2 Motor	On / Off	Normal speed
071.013	Option Feeder2 Motor	On / Off	Half speed
071.014	Option Feeder2 Motor	On / Off	Low speed
071.015	Option Feeder3 Motor	On / Off	Normal speed
071.016	Option Feeder3 Motor	On / Off	Half speed
071.017	Option Feeder3 Motor	On / Off	Low speed
071.018	Option Feeder1 Feed Clutch	On / Off	Auto Off (300ms)
071.019	Option Feeder2 Feed Clutch	On / Off	Auto Off (300ms)
071.020	Option Feeder3 Feed Clutch	On / Off	Auto Off (300ms)
071.021	Option Feeder1 Registration Clutch	On / Off	
071.022	Option Feeder2 Registration Clutch	On / Off	
071.023	Option Feeder3 Registration Clutch	On / Off	

Table 13 Chain 90 Component Output Codes

Chain-Link	Component Name	State	Comments
93.001	Toner Dispense Motor	On / Off	Normal speed
93.002	Toner Dispense Motor	On / Off	Half speed

Note:
Before running motors or clutches, +24vdc must be enabled using 041-001.

dC361 NVM Save and Restore

Purpose

To restore the NVM parameters of the machine to their previous values following a service action; i.e. NVM expansion, ESS or MCU Board replacement, or any others that would necessitate a full NVM initialization. It can also be used to recover a machine's NVM values to a recent service call, in the event that a complete NVM failure occurred. As an additional tool, the ability to copy files between the hard drive and a USB drive is provided.

The NVM save to hard disk must be performed at the first service call and whenever the system software is changed.

This procedure will save and restore only the ESS, IIT and MCU NVM.

NOTE: After a USB flash drive is first connected to the machine a UI screen message offering scan to and print from USB options will display. This screen message can be closed or left open before entering diagnostics without effecting the NVM save / restore processes. If you choose to close the scan to and print from USB screen message it will not reappear on exit from diagnostics. Therefore, leave this message screen open if the scan to and print from USB options are to be required after a NVM save / restore.

Procedure

NVM Save

1. If necessary, connect the USB flash drive to the USB port on the left side of the machine.
2. Enter Service Diagnostics, GP 1.
3. Select the Adjustments tab.
4. Select dC361 NVM Save and Restore.

The screen displays the NVM data.

NOTE:

- The top entry displays the live NVM data for the machine.
- If the data has previously been saved to the hard disk these will be displayed in a list below the live data.
- If a USB device containing NVM data is connected these will be displayed below the hard disk data. To be recognized by the machine the USB device must be connected at the time dC361 is started.

5. Save the NVM data.
 - To save the live data to the hard disk select the live data entry and select save to hard disk.
 - To save the hard disk data to a USB device select the hard disk entry and select save to USB device.
 - To save the USB data to the hard disk select the USB entry and select save to HDD.

NOTE: Data cannot be saved or restored directly to or from the USB device to the machine.

6. Select Close to return to the service mode window.
7. Select Call Closeout to exit service mode

NVM Restore

1. If necessary, connect the USB drive to the USB port on the left side of the machine.
2. Enter service mode, GP 1.
3. Select the Adjustments tab.
4. Select dC361 NVM Save and Restore.
The screen displays the NVM data.
5. Restore the NVM data.

- a. Select the entry from the available NVM data on the hard drive.

NOTE: NVM data on a USB device should be copied to the hard drive before it can be restored.

- b. Select Restore Machine NVM.

The status region at the top of the screen will report that the NVM was restored successfully.

6. Select Close to return to the service mode window.
7. Select Call Closeout to exit service mode.

dC612 Print Test Pattern

Purpose

To print embedded test prints useful for troubleshooting print quality problems.

1. Enter diagnostics, refer to GP 1.
2. Select the Diagnostics tab, then dC612 Print Test pattern.
3. Select the test pattern from those listed on the display.
 - Gradation ESS
 - Ghost Chart ESS
 - Test pattern 1 (letter/A4)
 - 100% Solid (Black)
 - 20% halftone (Grey Scale)
 - Total PQ Chart (letter/A4)
 - Alignment Chart (letter/A4)
 - Halftone Representation Chart (letter/A4)

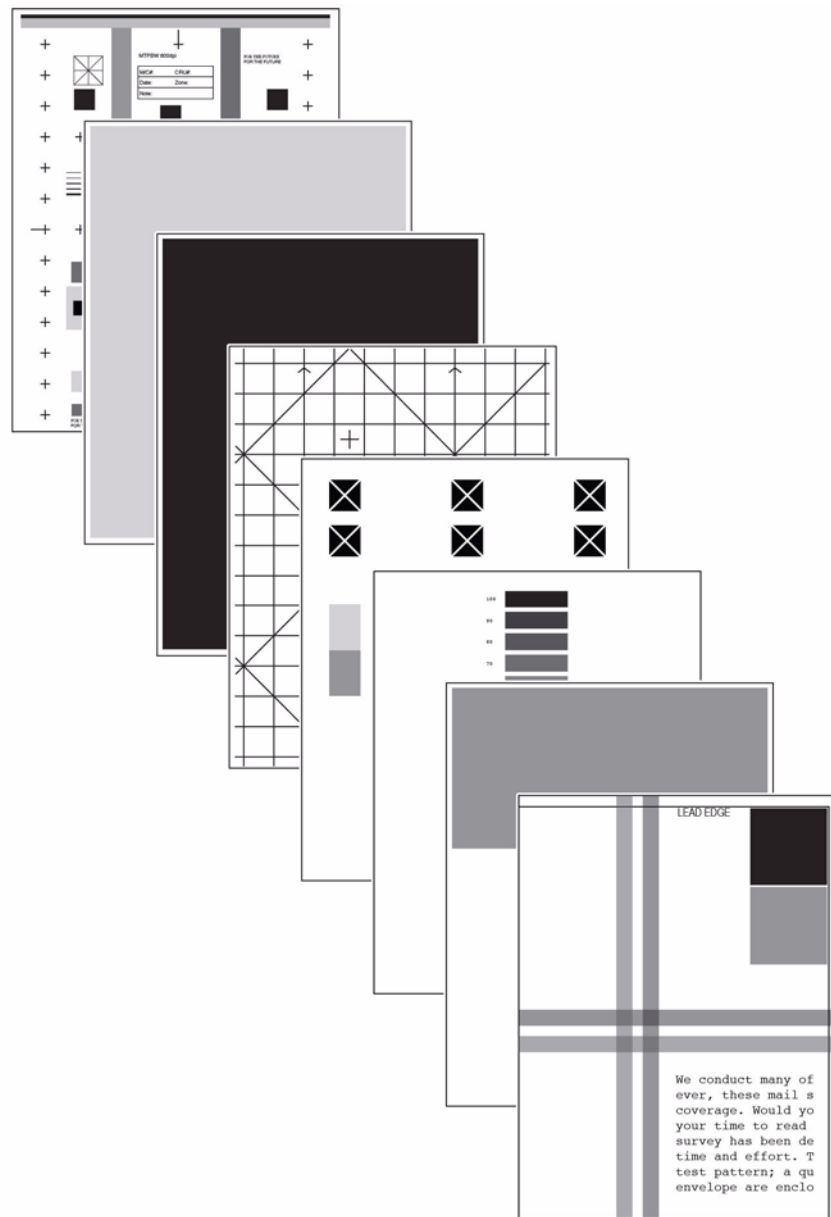

s3655-141

Figure 1 Available test prints

dC945 IIT Calibration

Purpose

To adjust the White reference settings (RGB and Mono) for the Scanner.

1. Enter diagnostics, refer to GP 1.
2. Select the Adjustments tab, then dC945 IIT Calibration.
3. Follow the instructions on the screen to calibrate the CCD sensor.

Change Tags

Change Tag Introduction

This section describes tags associated with the printer, as well as multinational applicability, classification codes, and permanent or temporary modification information. Important modifications to the copier are identified by a tag number which is recorded on a tag matrix.

The tag matrix for the IOT is affixed to the chassis inside the Front Door.

Classification Codes

A tag number may be required to identify differences between parts that cannot be interchanged, or differences in diagnostic, repair, installation, or adjustment procedures.

A tag number may also be required to identify the presence of optional hardware, special non-volatile memory programming, or whether mandatory modifications have been installed. Each tag number is given a classification code to identify the type of change that the tag has made. The classification codes and their descriptions are listed in Table 1.

Table 1 Classification Codes

Classification Code	Description
M	Mandatory tag.
N	Tag not installed in the field.
O	Optional tag.
R	Repair tag.

Change Tags

There are no Change Tags currently in effect for this product.

Plug and Jack Locations

How to Use the Plug/ Jack Location List..... 7-3

Harness Routing

Chassis Wire Routing..... 7-9

Optional Feeder Wire Routing..... 7-16

Wiring Diagrams

Wiring Diagrams..... 7-19

Table 1 Plug / Jack locations

How to Use the Plug/ Jack Location List

The P/J Locator diagrams show the location of primary connections within the printer. Use these illustrations to locate connections called out in the procedures presented in Sections 2, 4, and 6. Connectors designated "CN" are listed at the end of the P/J connectors.

Harness routing is diagrammed in Chassis Wire Routing. Harness connections appear in Wiring Diagrams.

How to find a P/J location:

1. Locate the P/J connector designator in the first column of the table.
2. With this information, go to the second column (Map - Figure Number).
3. Use the coordinates to locate the connection on the map with its P/J designation number.

Table 1 Plug / Jack locations

PJ	Map	Coordinates	Connection
P/J10	Figure 2	A-110	MCU Board and harness MAIN MOT
P/J11	Figure 2	F-112	MCU Board and harness DISP MOT
P/J12	Figure 2	D-112	MCU Board and REGI Clutch
P/J13	Figure 2	A-111	Not Connected
P/J14	Figure 2	B-112	MCU Board and CST FEED Clutch
P/J15	Figure 2	A-111	MCU Board and Solenoid Feed MSI
P/J16	Figure 2	C-112	MCU Board And Clutch Assy Exit
P/J17	Figure 2	C-112	MCU Board and Clutch Assy Invert
P/J18	Figure 2	G-110	MCU Board and Laser Unit
P/J19	Figure 2	G-109	MCU Board and harness ROS-MCU
P/J20	Figure 2	F-109	MCU Board and harness ESS
P/J21	Figure 2	G-111	MCU Board and harness MCU24V
P/J22	Figure 2	B-109	MCU Board and harness LV
P/J23	Figure 2	A-109	MCU Board and harness FSR
P/J24	Figure 2	C-109	MCU Board and harness OP FDR
P/J25	Figure 2	D-109	Board and harness XERO CRUM
P/J26	Figure 2	E-112	MCU Board and harness HV
P/J27	Figure 2	B-110	MCU Board and harness SENS EXIT
P/J30	Figure 2	G-109	Not used
P/J101	Figure 4	F-107	Main Drive Assembly and harness MAIN MOT
P/J111	Figure 5	E-108	Toner Dispense Motor and harness DISP MOT
P/J200	Figure 1	H-188	LVPS and KIT AC INLET
P/J201	Figure 1	H-187	LVPS and harness FSR
P/J202	Figure 1	H-188	LVPS and harness Stapler LVPS
P/J210	Figure 1	H-185	LVPS and harness MCU24V
P/J211	Figure 1	H-185	LVPS and harness ESS PWR
P/J212	Figure 1	I-185	LVPS and harness MAIN MOT
P/J213	Figure 1	H-185	LVPS and harness OP FD
P/J220	Figure 1	H-186	LVPS and harness LV

PJ	Map	Coordinates	Connection
P/J230	Figure 1	H-185	LVPS and harness INTLK
P/J231	Figure 4	J-185	LVPS and Front Interlock Switch
P/J233	Figure 4	F-108	Fuser and harness MCU-FUSING
P/J240	Figure 1	I-185	LVPS and harness Rear Fan
P/J241	Figure 1	J-185	LVPS and LVPS Fan
P/J243	Figure 6	K-182	Harness FDR DRAWER 1 and harness OP FDR
P/J253	Figure 5	E-107	Connector CRUM TONER and harness XERO CRUM
P/J254	Figure 5	D-107	Connector Assy XERO and harness XERO CRUM
P/J261	Figure 2	F-106	HVPS and harness HV
P/J271	Figure 4	E-107	Exit Sensor and harness SENS EXIT
P/J272	Figure 4	E-154	Stack Sensor and harness SENS EXIT
P/J300	Figure 1	D-185	ESS Board and harness IIT Control Board
P/J302	Figure 1	D-186	ESS Board and HDD
P/J310	Figure 1	D-186	ESS Board and HDD
P/J320	Figure 1	D-188	ESS Board and harness MCU-ESS
P/J328	Figure 1	D-188	ESS Board and harness video
P/J330	Figure 1	B-188	ESS Board and RAM
P/J336	Figure 1	D-185	ESS Board and flat cable
P/J340	Figure 1	B-187	ESS Board Ethernet Port
P/J343	Figure 1	D-185	ESS Board and Side USB Assembly
P/J344	Figure 1	B-186	ESS Board and USB port
P/J345	Figure 1	B-185	ESS Board and Fax Board
P/J346	Figure 1	B-186	ESS Board and USB port
P/J352	Figure 1	C-185	ESS Board and Control Panel
P/J390	Figure 1	C-185	ESS Board and harness IIT Control Board
P/J401	Figure 1	C-181	IIT Control Board and harness IITMCU-LVPS
P/J402	Figure 1	C-181	IIT Control Board and harness IITMCU-ESS2
P/J403	Figure 1	B-182	IIT Control Board and harness SUBLV-IITMCU
P/J419	Figure 6	H-182	Feeder Board and harness FDR DRAWER 1
P/J420	Figure 6	G-183	Feeder Board and harness C2 TURN
P/J421	Figure 6	G-183	Feeder Board and harness C2 SIZE
P/J422	Figure 6	G-183	Feeder Board and harness TRAY MOT
P/J423	Figure 6	H-183	Feeder Board and harness FDR DRAWER 2
P/J431	Figure 1	B-182	IIT Control Board and flat cable
P/J432	Figure 1	A-182	IIT Control Board and harness IITMCU-ESS
P/J451	Figure 1	A-181	IIT Control Board and IIT Assy
P/J452	Figure 1	C-181	IIT Control Board and IIT Assy
P/J453	Figure 1	B-181	IIT Control Board and DADF Assy
P/J454	Figure 1	A-181	IIT Control Board and IIT Assy
P/J501	Figure 3	D-102	Laser Unit and harness ROS-MCU
P/J502	Figure 3	E-102	Laser Unit and harness VIDEO
P/J800	Figure 5	I-106	Stapler LVPS and harness SUBLV-LVPS

Table 1 Plug / Jack locations

PJ	Map	Coordinates	Connection
P/J801	Figure 5	H-105	Stapler LVPS and harness SUBLV-STAPLER ASSY
P/J802	Figure 5	H-106	Stapler LVPS and harness SUBLV-STAPLER ASSY
P/J1332	Figure 1	B-186	ESS Board and SD Card
P/J2401	Figure 4	D-110	Rear Fan and harness Rear Fan
P/J4201	Figure 6	F-184	Option Feed Clutch and harness C2 TURN
P/J4203	Figure 6	D-182	No Paper Sensor and harness C2 TURN
P/J4211	Figure 6	J-183	Size Switch and harness C2 SIZE
P/J4212	Figure 6	C-182	Path Sensor and harness OPT LEG
P/J4213	Figure 6	F-184	Take Away Clutch [Clutch REGI] and harness C2 SIZE
P/J4214	Figure 6	F-184	Harness C2 SIZE and harness OPT LEG
P/J4221	Figure 6	E-183	MOTOR Assy OPTION and harness Assy TRAY MOT
P/J4231	Figure 6	J-184	Harness FDR DRAWER 2 and FDR DRAWER 1
P/J8011	Figure 5	H-105	Stapler and harness SUBLV-STAPLER ASSY

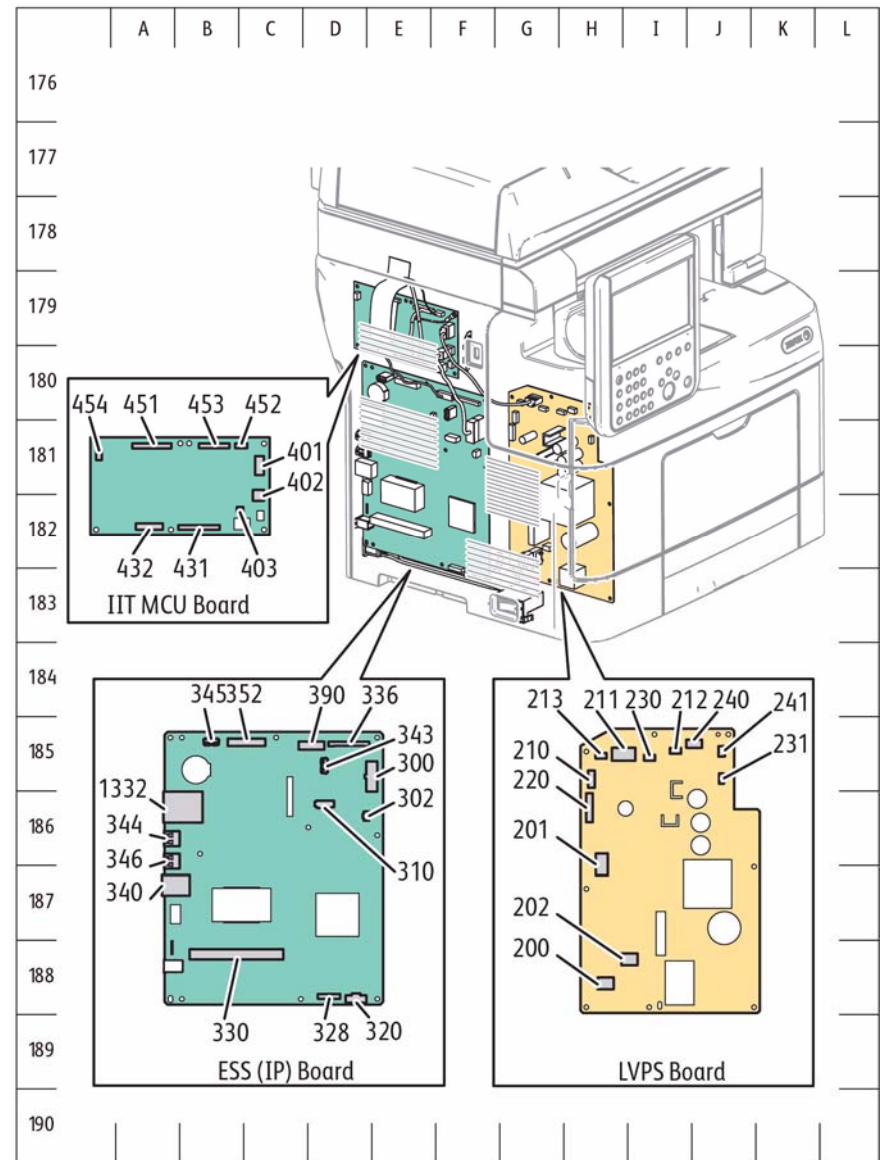

s3655-175

Figure 1 P/J locator map 1

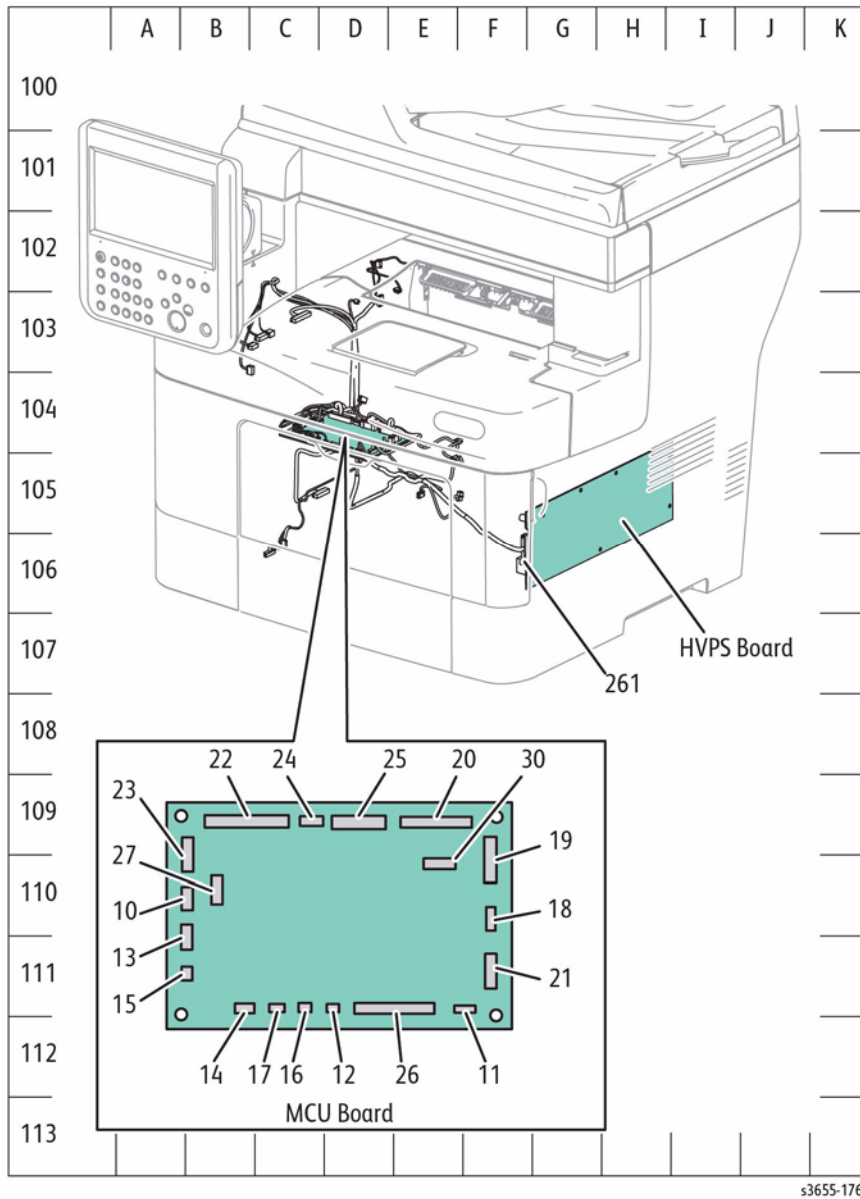

Figure 2 P/J locator map 2

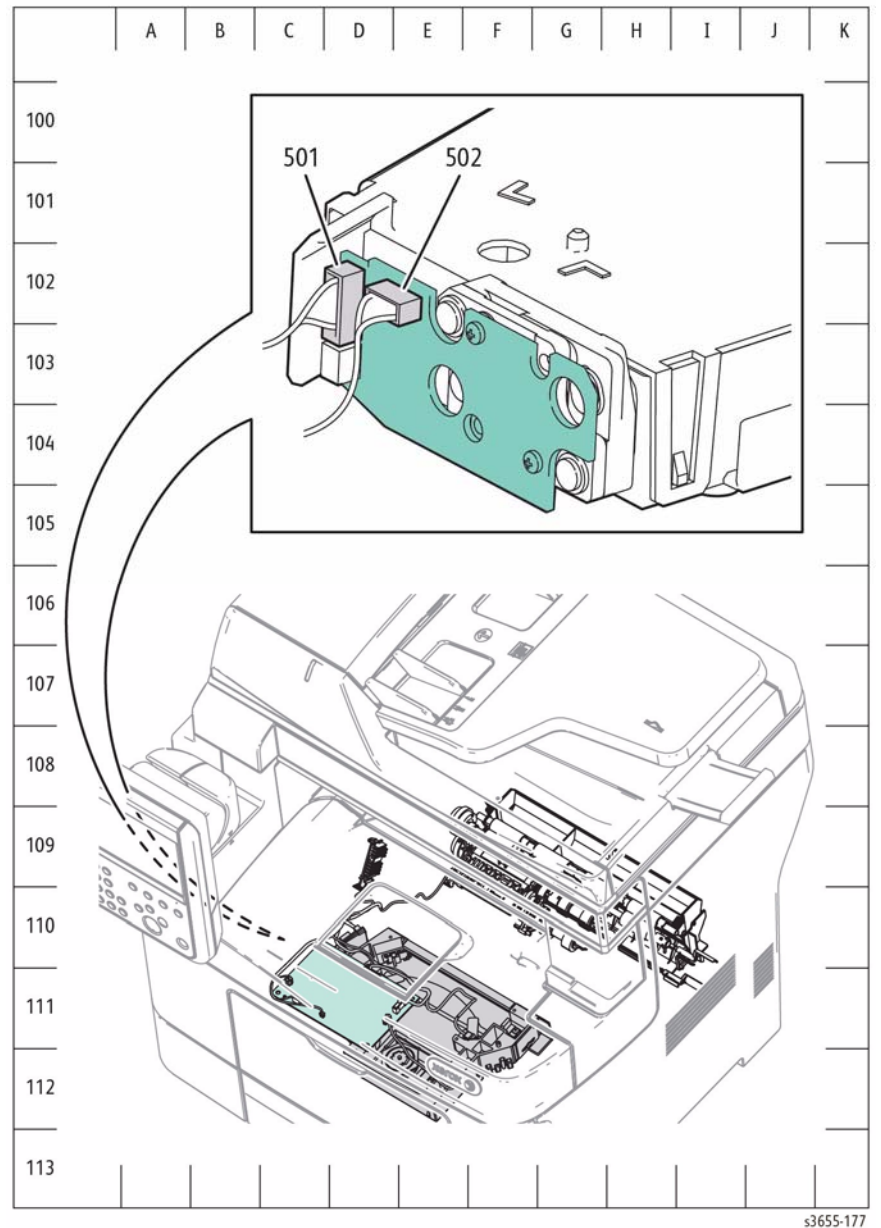
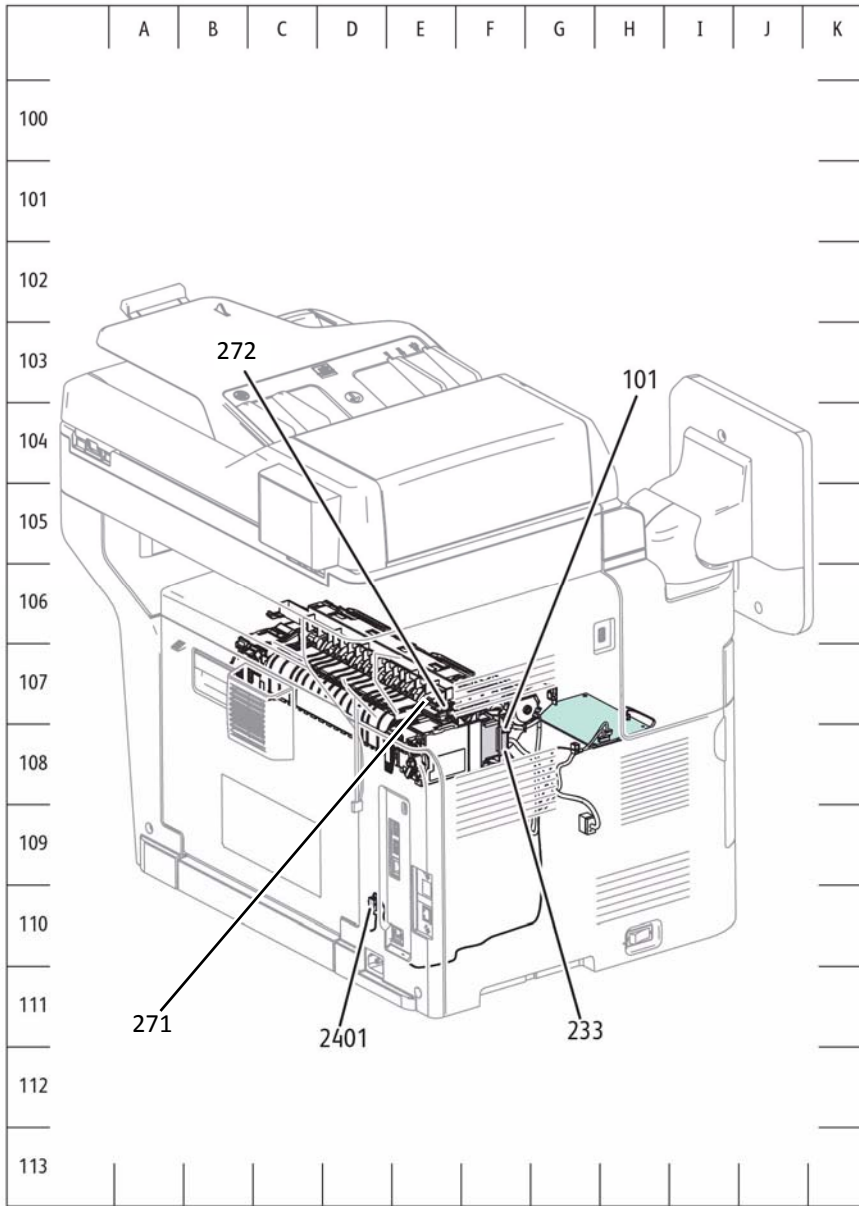
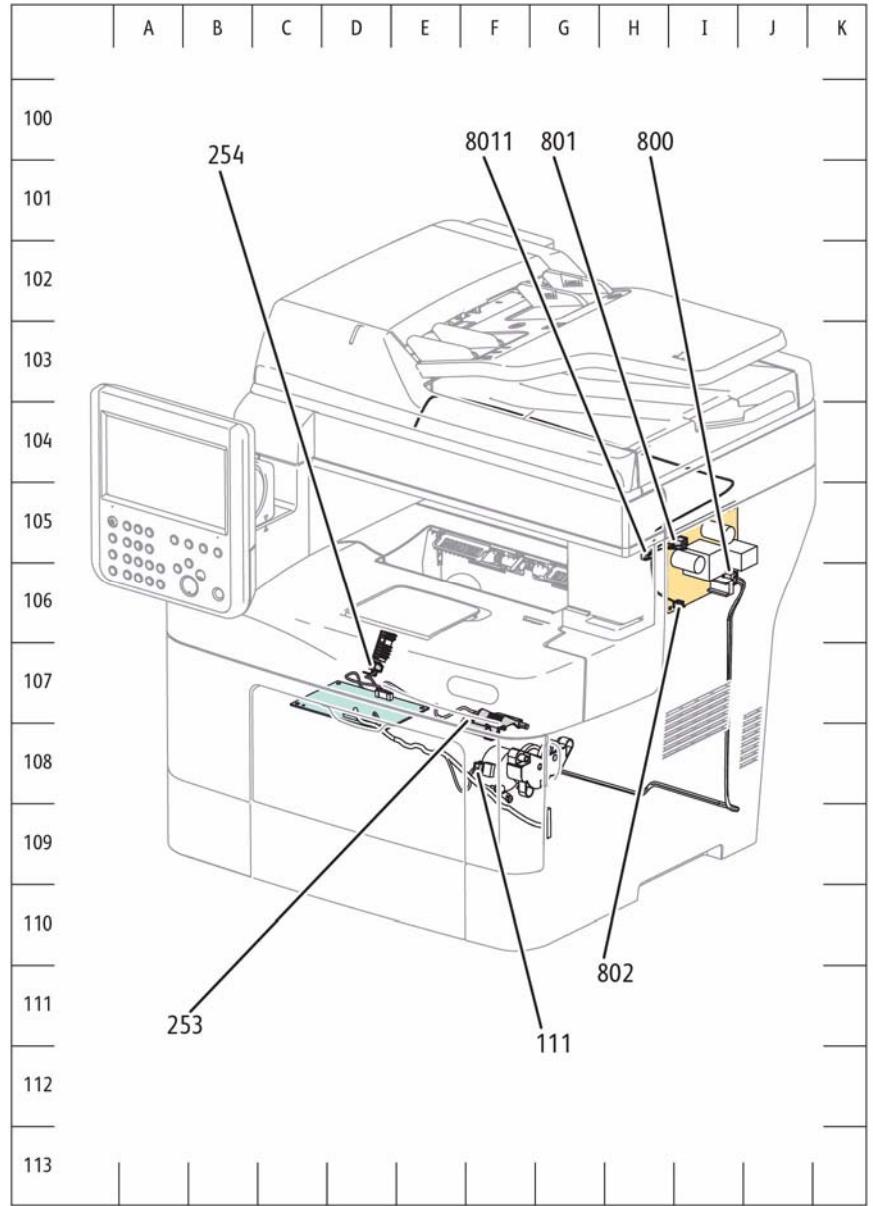

Figure 3 P/J locator map 3



s3655-178

Figure 4 P/J locator map 4



s3655-179

Figure 5 P/J locator map 5

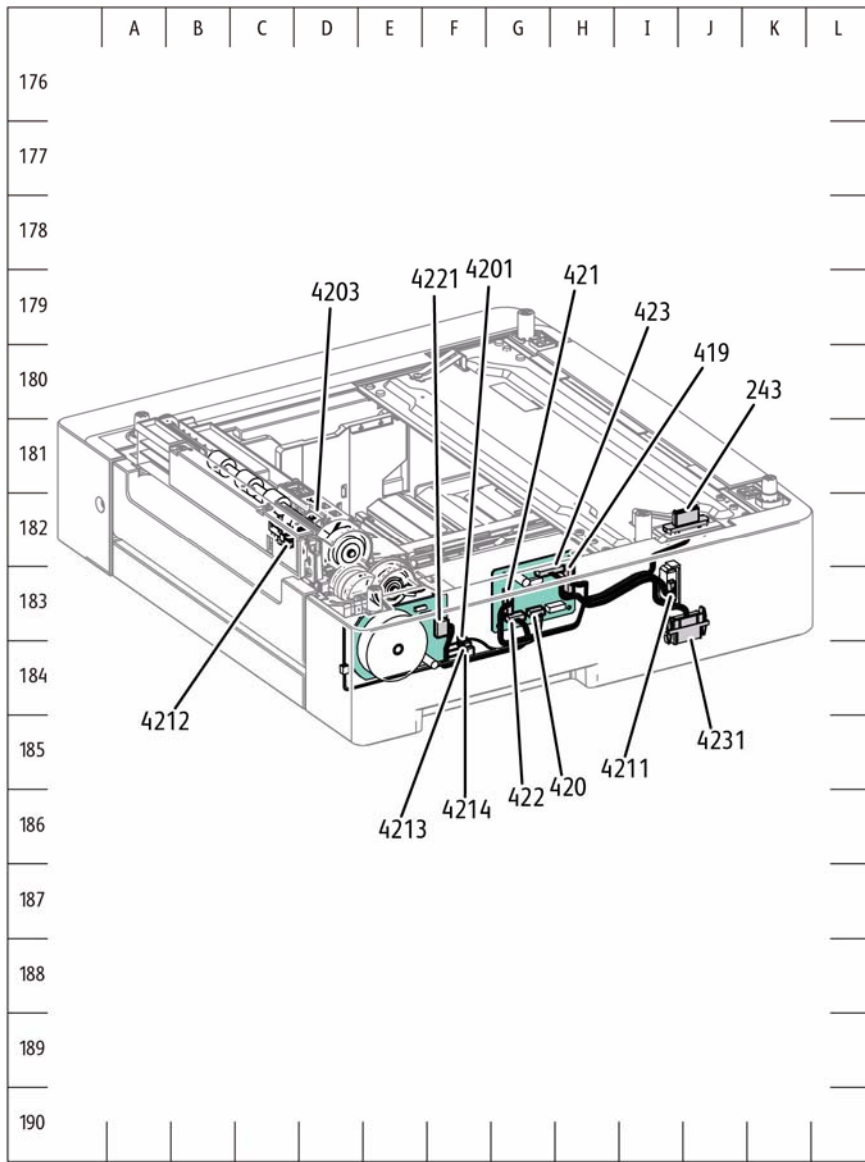

s3655-084

Figure 6 P/J locator map 6

Chassis Wire Routing

The following illustrations show factory harness routing paths through the chassis. Refer to Table 1 for a list of available routing diagrams.

Table 1 Wire Routing Diagrams

Diagram	Description
Figure 1	MCU Board to HVPS / Dispense Motor Assembly
Figure 2	MCU Board to Xerographic Connector
Figure 3	MCU Board to Main Motor Assembly / LVPS
Figure 4	MCU Board to Optional Feeder Connector
Figure 5	MCU Board to Laser Unit (ROS)
Figure 6	Laser Unit to ESS Board
Figure 7	MCU Board to Full Stack Sensor / Exit Sensor
Figure 8	MCU Board to LVPS (1 of 2)
Figure 9	MCU Board to LVPS (2 of 2)
Figure 10	MCU Board to ESS Board
Figure 11	MCU Board to Laser Unit (ROS)
Figure 12	Laser Unit to ESS Board
Figure 13	IIT, ESS Board to LVPS / Control Panel

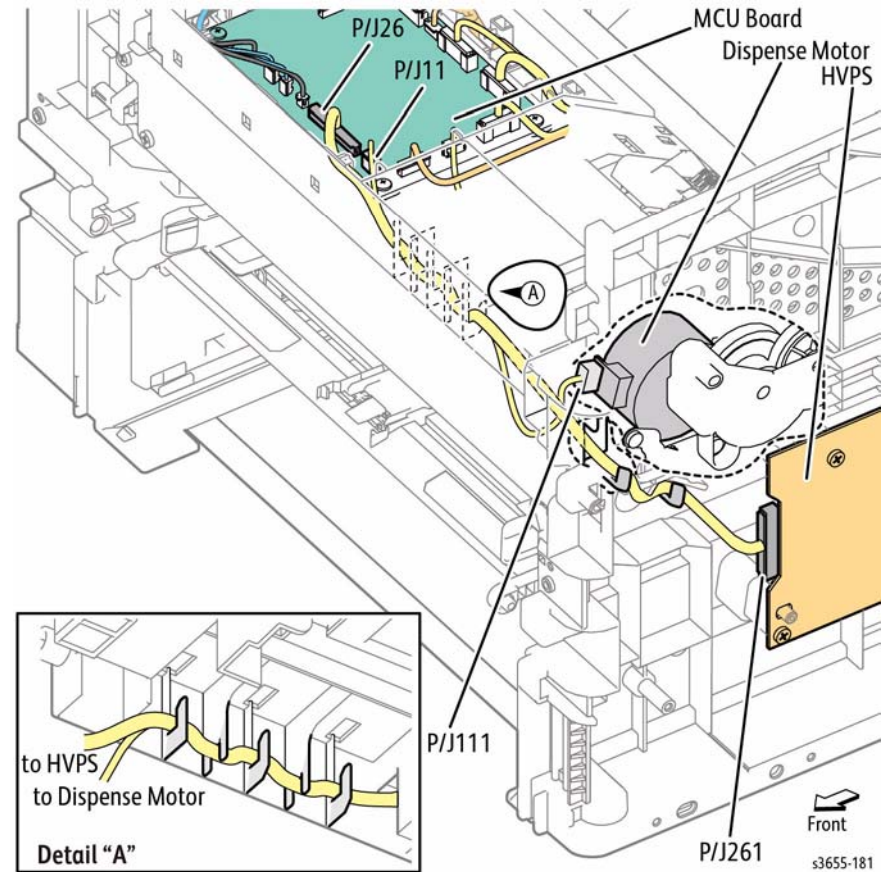

Figure 1 MCU Board to HVPS / Dispense Motor Assembly

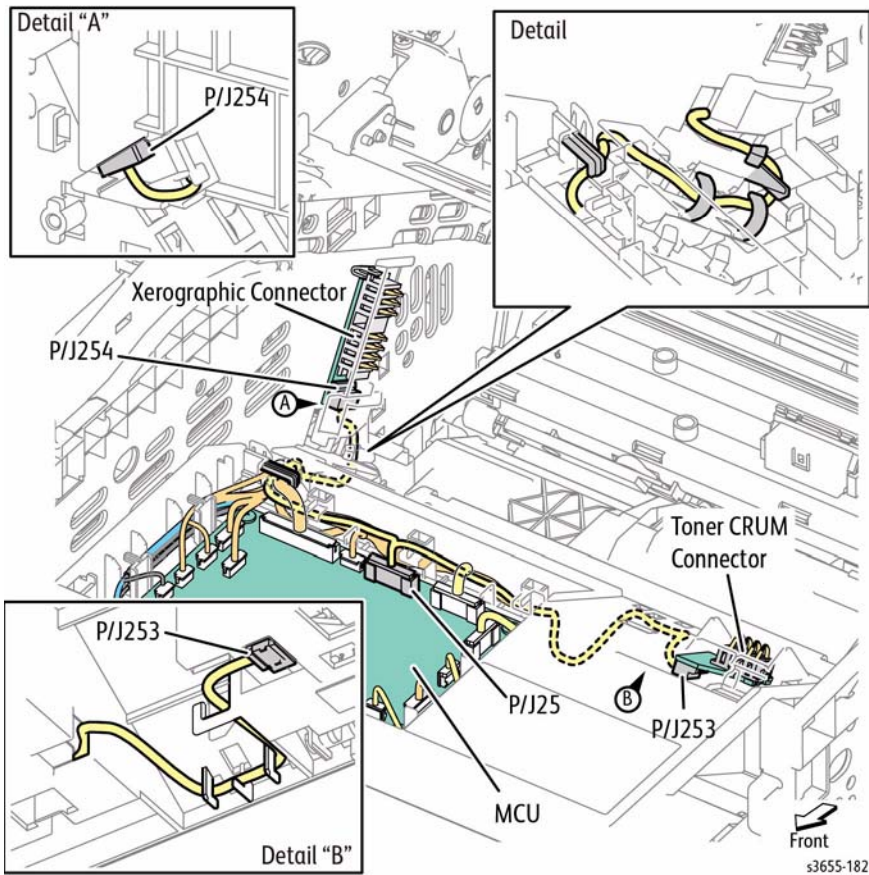

Figure 2 MCU Board to Xerographic Connector

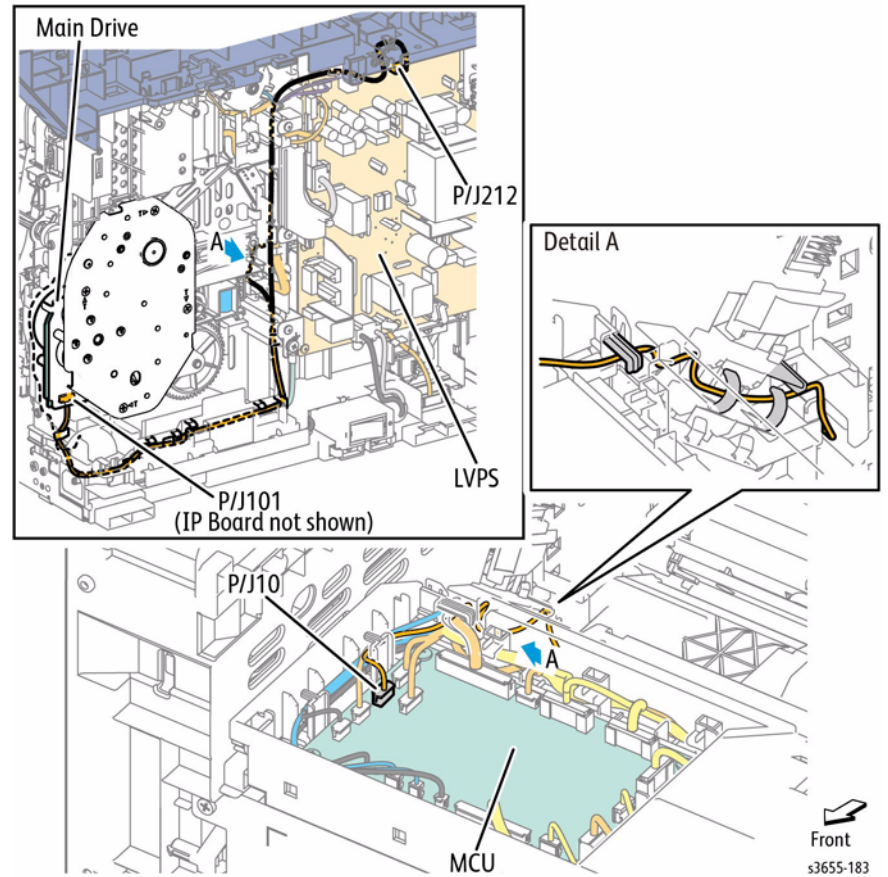

Figure 3 MCU Board to Main Motor Assembly / LVPS

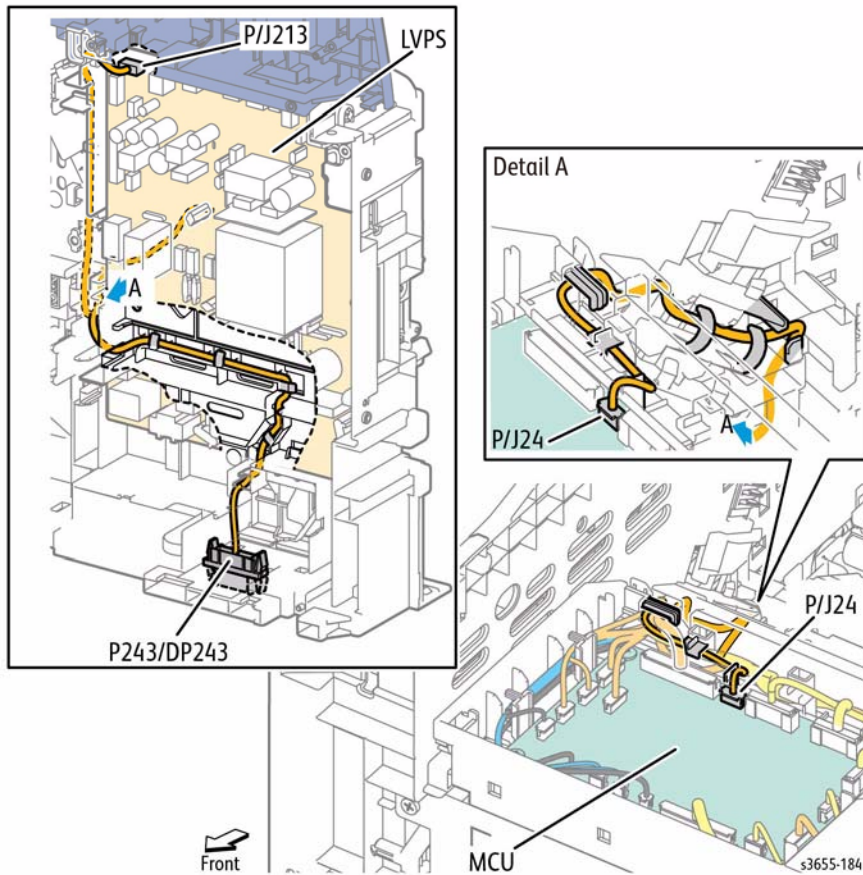

Figure 4 MCU Board to Optional Feeder Connector

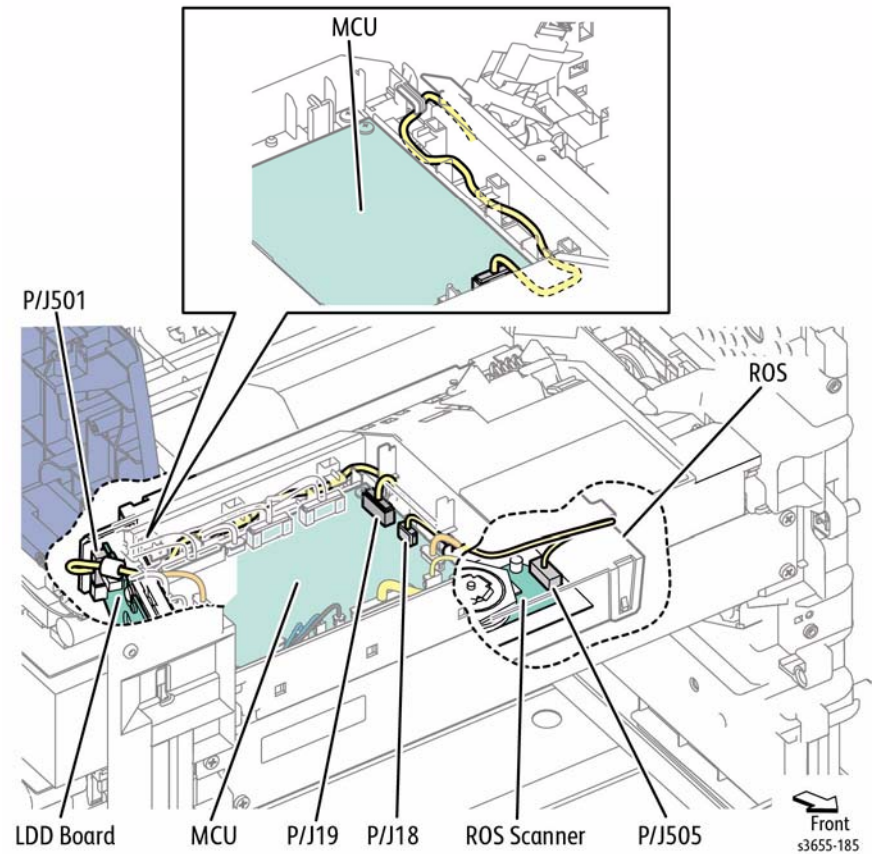

Figure 5 MCU Board to Laser Unit (ROS)

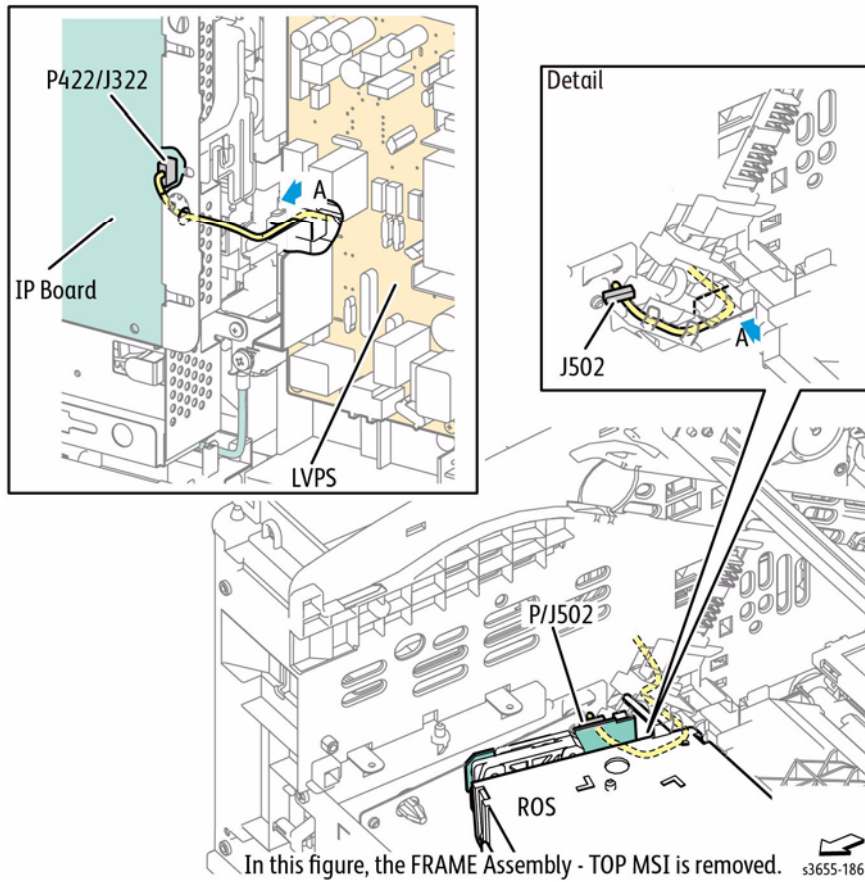

Figure 6 Laser Unit to ESS Board

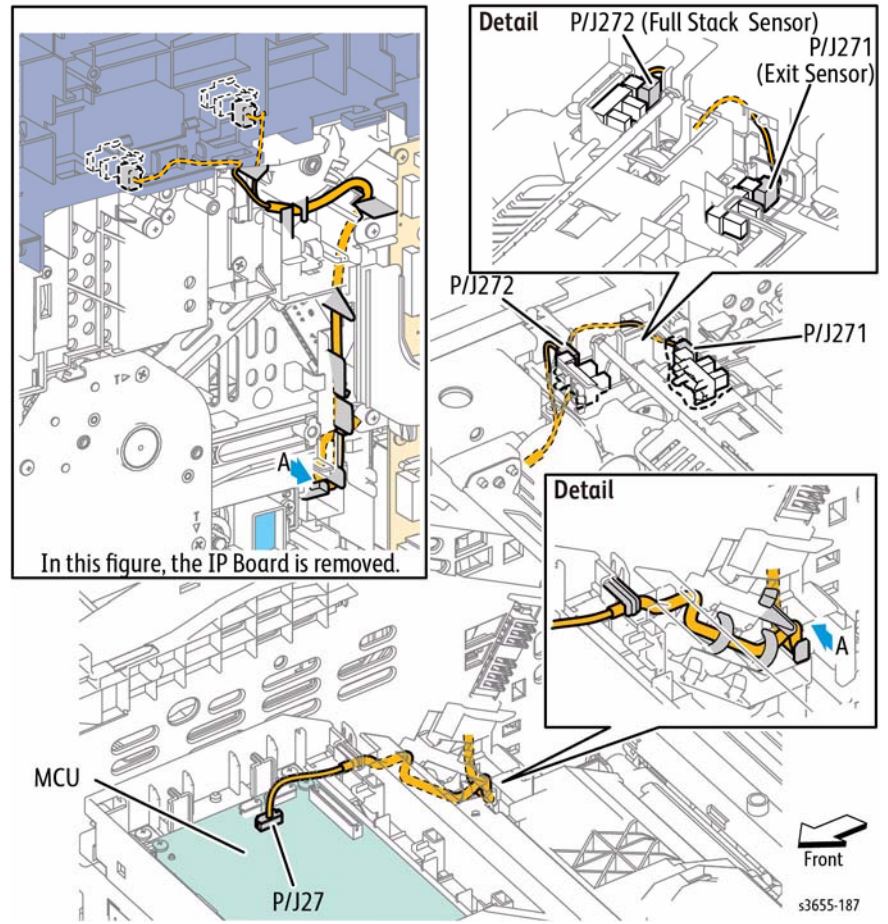

Figure 7 MCU Board to Full Stack Sensor / Exit Sensor

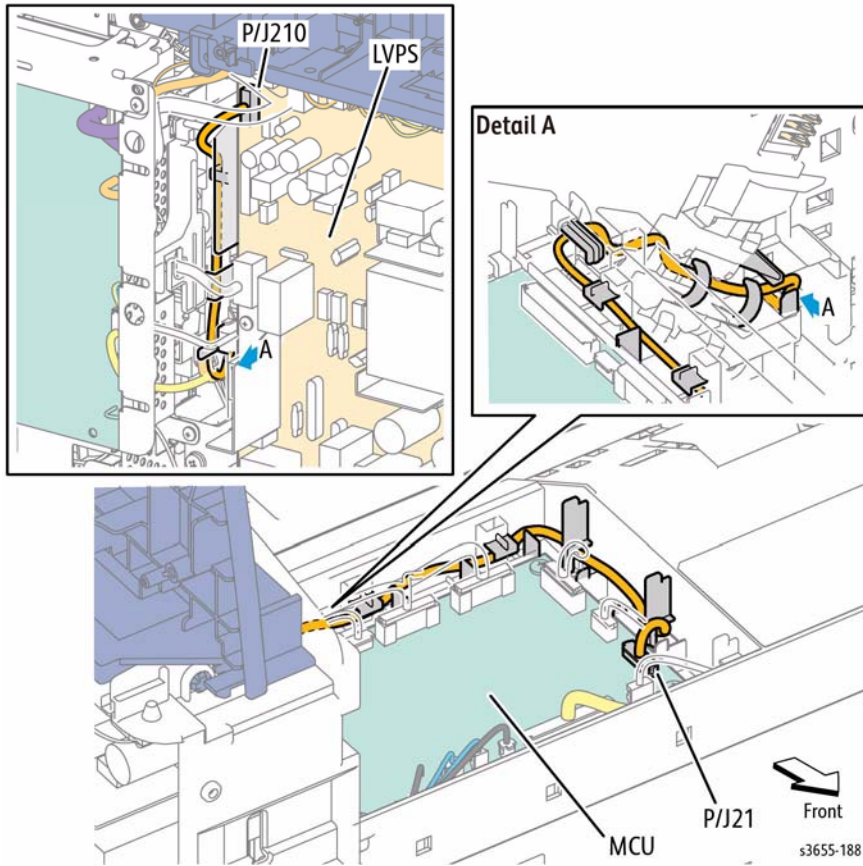

Figure 8 MCU Board to LVPS (1 of 2)

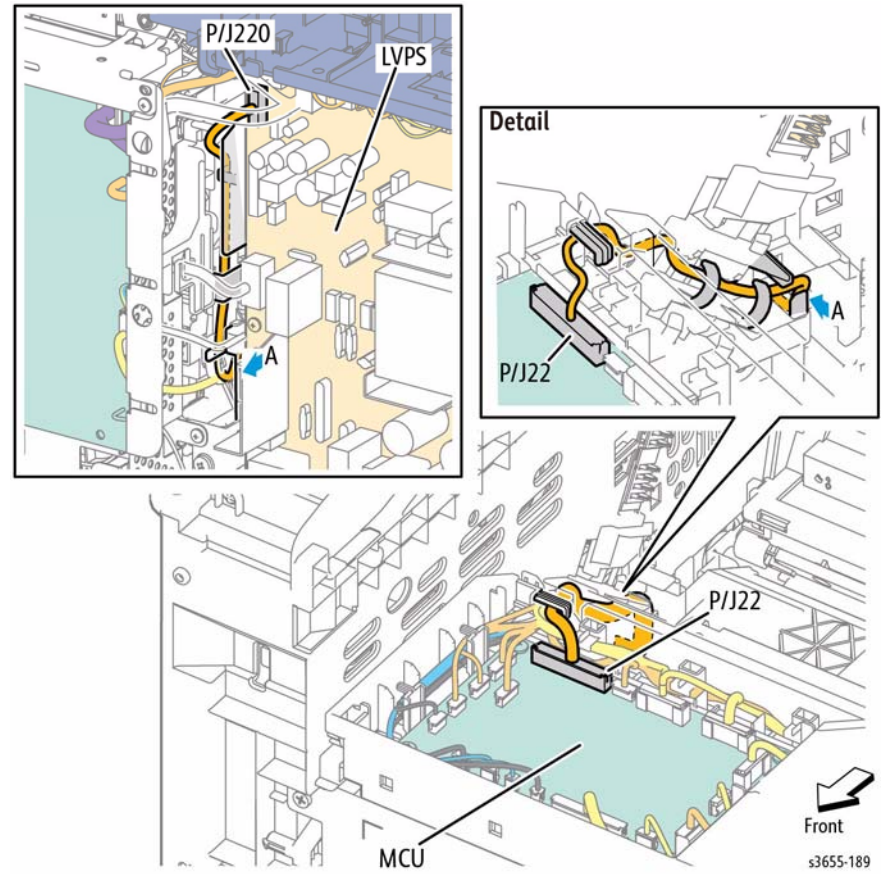

Figure 9 MCU Board to LVPS (2 of 2)

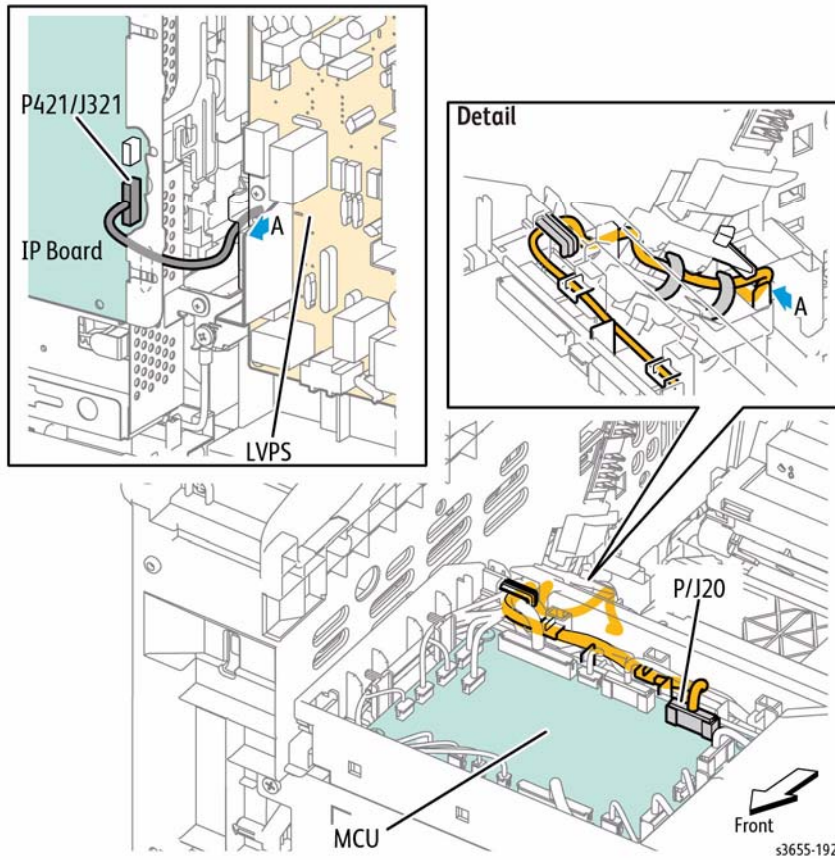

Figure 10 MCU Board to ESS Board

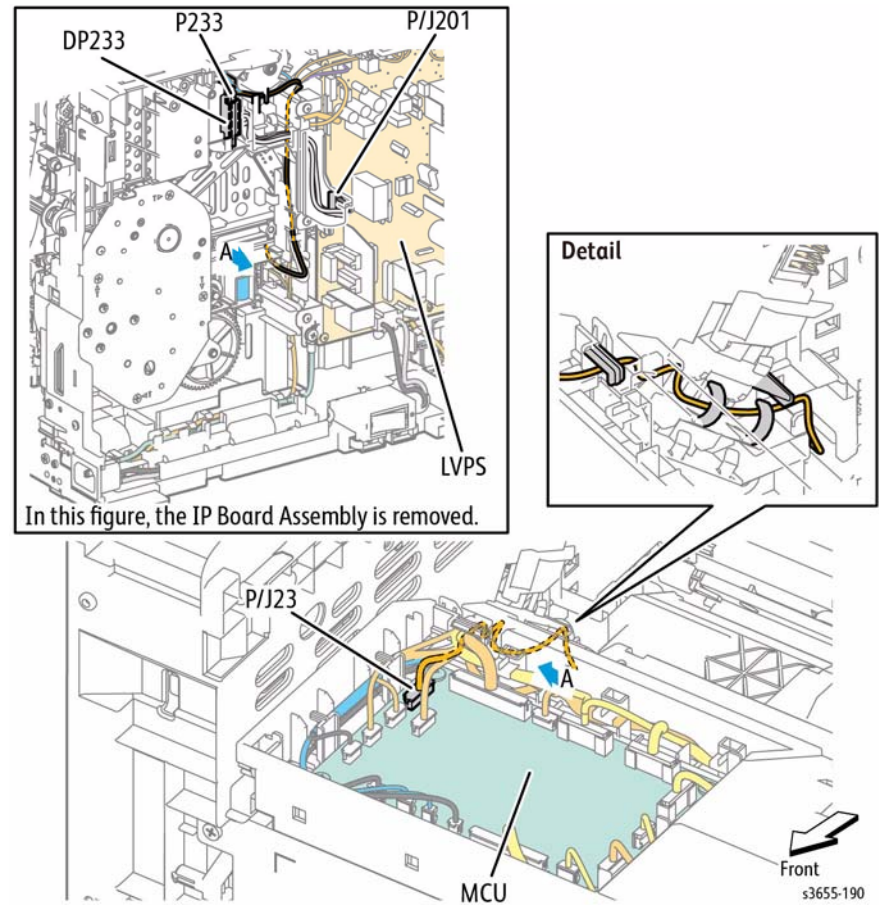
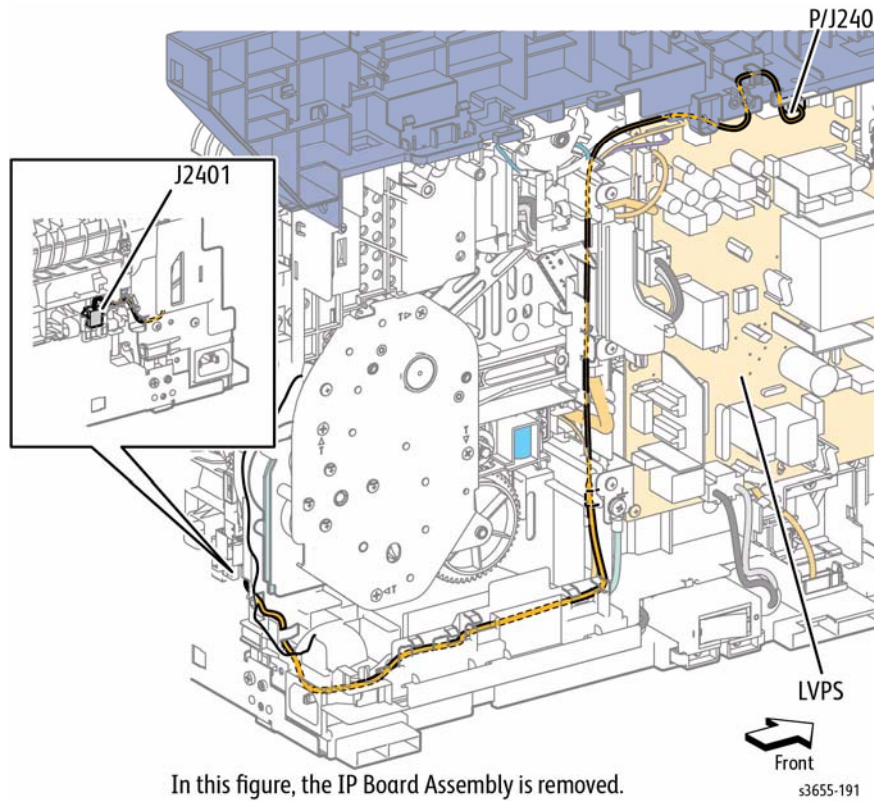

Figure 11 MCU Board to Fuser



In this figure, the IP Board Assembly is removed.

Figure 12 MCU Board to Rear Fan connector

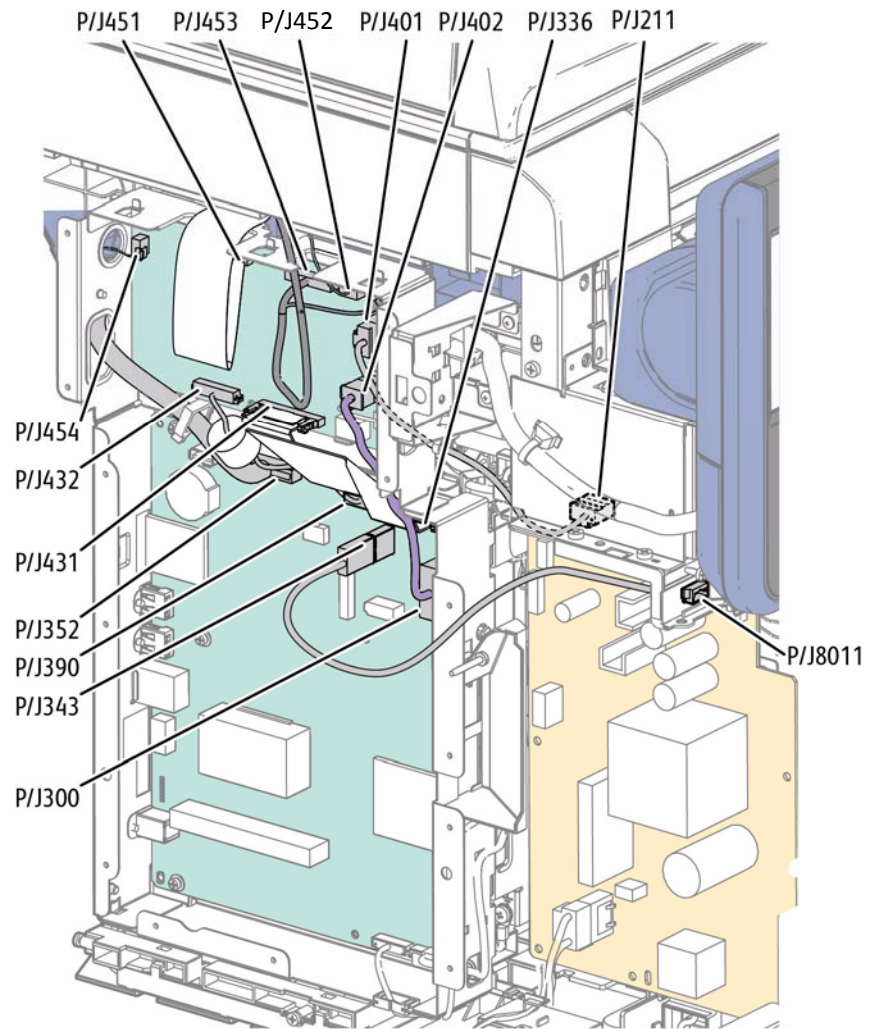

Figure 13 ESS Board to LVPS / Control Panel

Optional Feeder Wire Routing

The following illustrations show wire routing for the 550-Sheet optional tray.

Table 1 Wire Routing Diagrams

Diagram	Description
Figure 1	No Paper Sensor
Figure 2	Pre-Registration Sensor
Figure 3	Optional Tray PWB (1 of 2)
Figure 4	Optional Tray PWB (2 of 2)

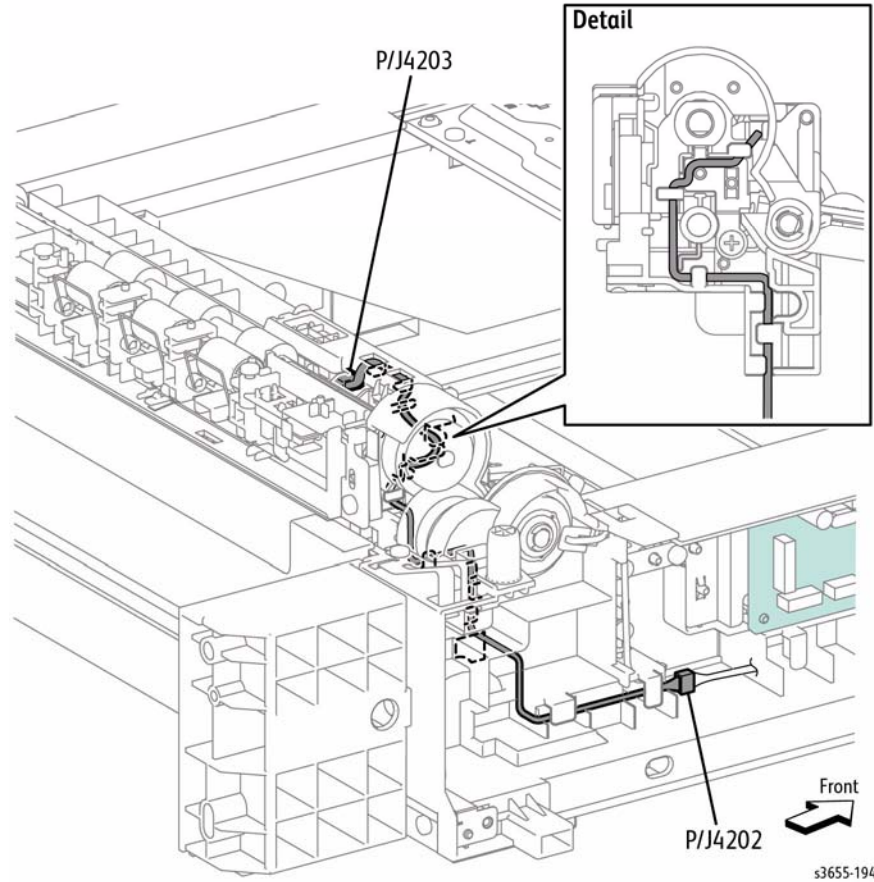

Figure 1 No Paper Sensor

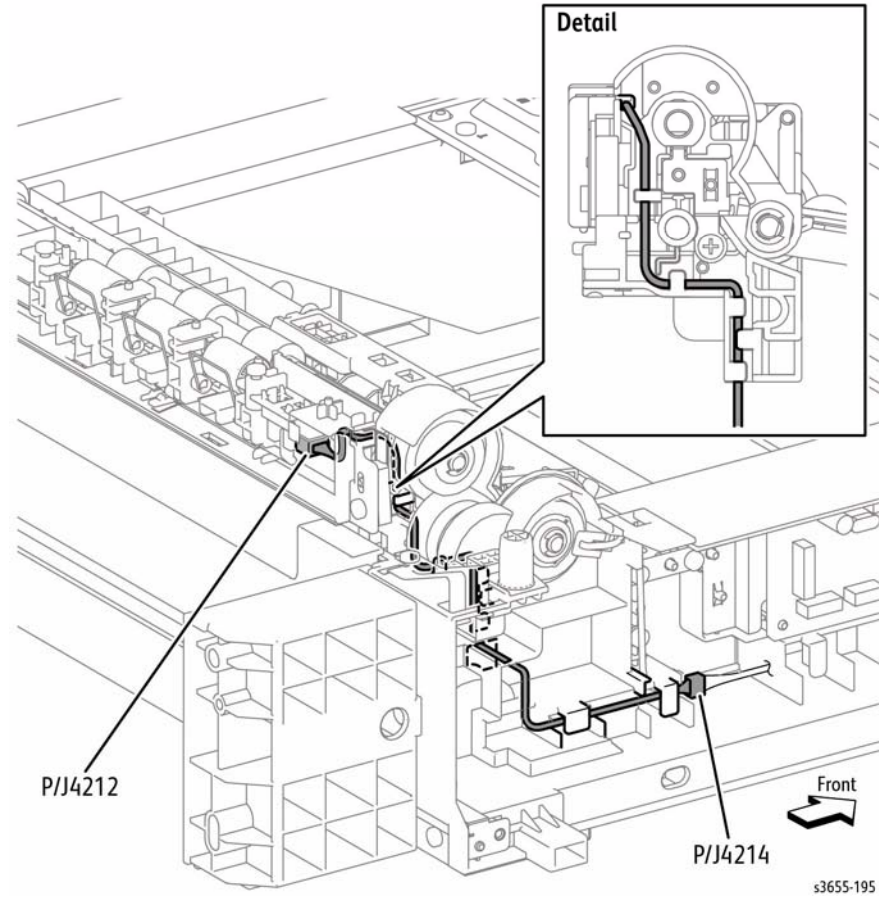

Figure 2 Pre-Registration Sensor

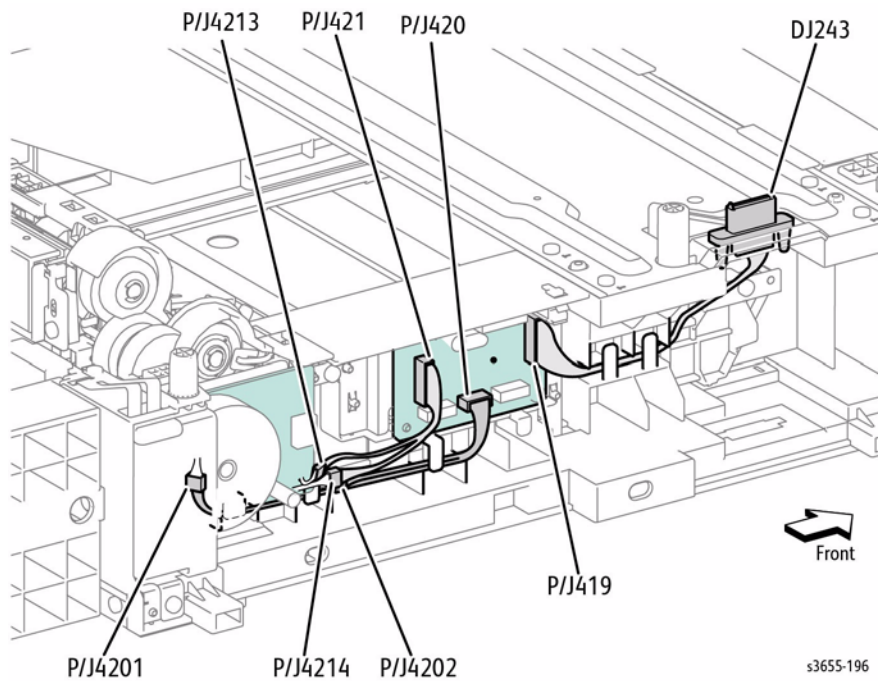

Figure 3 Optional Tray PWB (1 of 2)

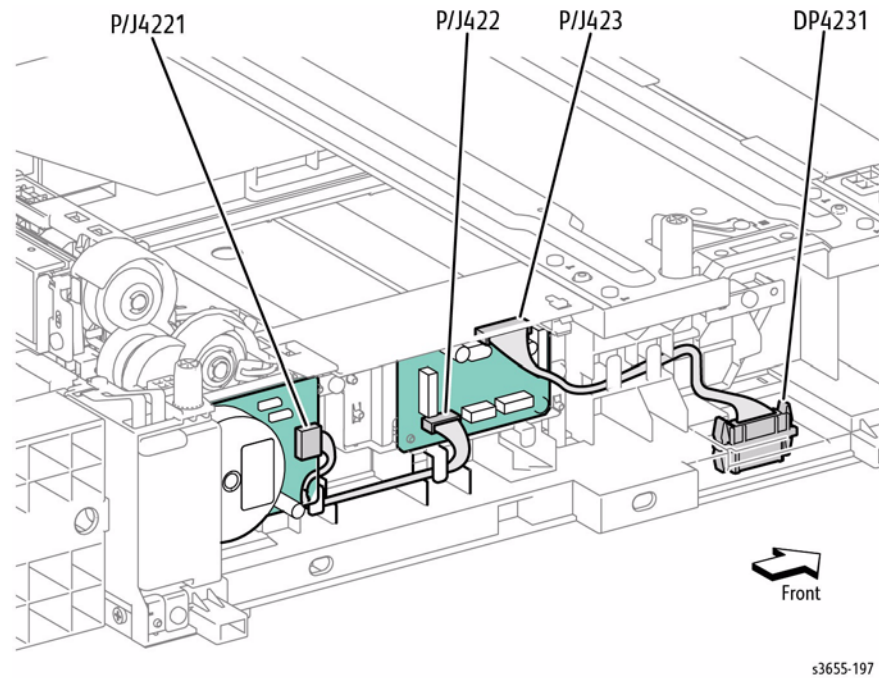

Figure 4 Optional Tray PWB (2 of 2)

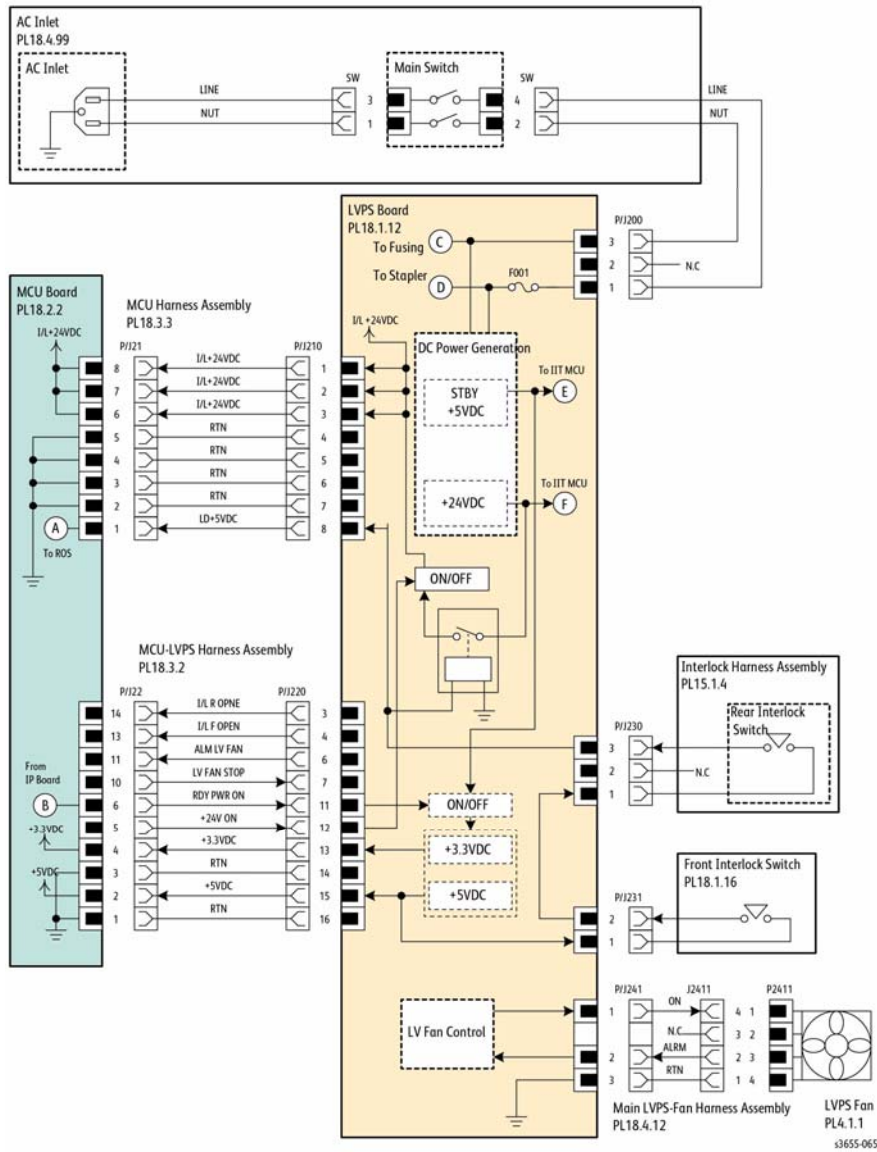

Figure 2 Power regulation and distribution

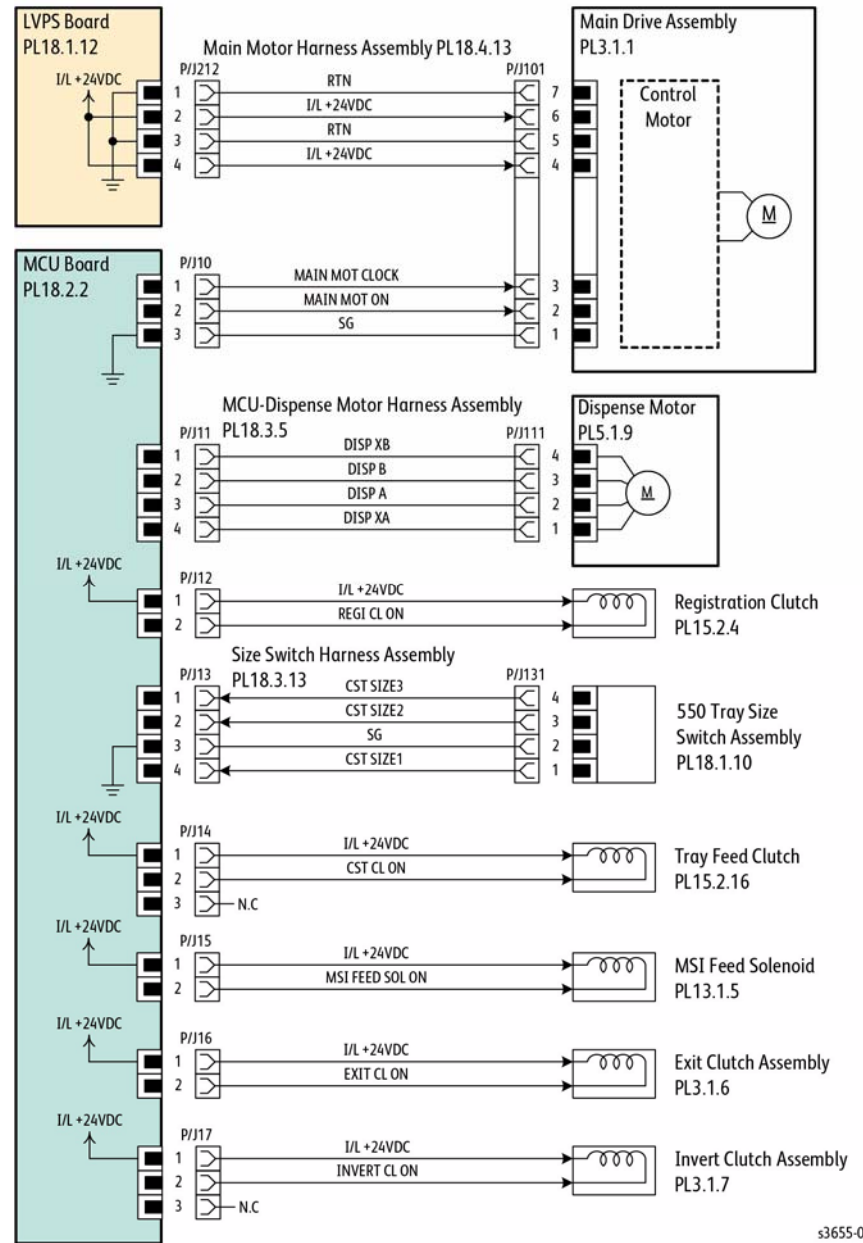
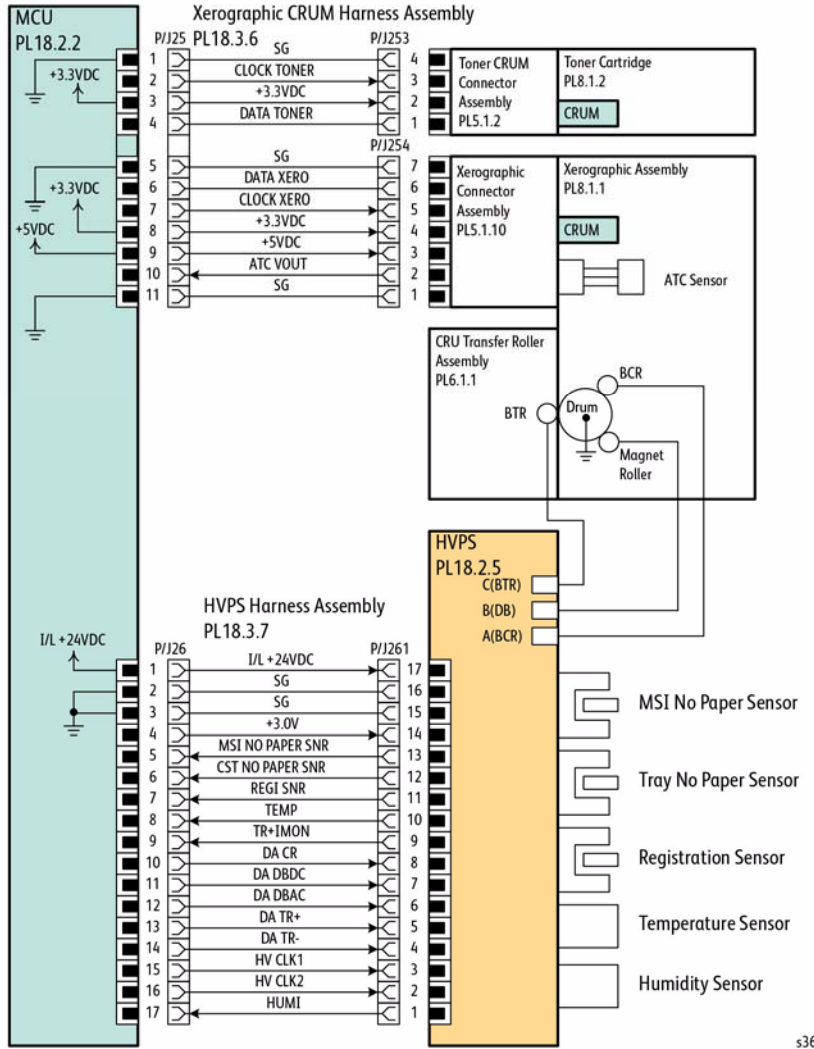
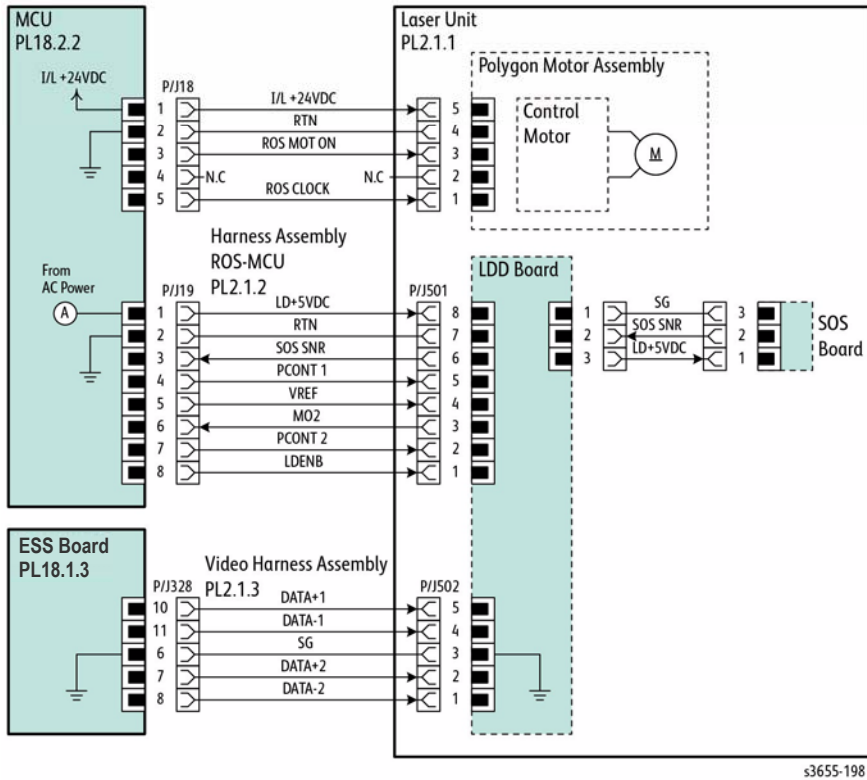

Figure 3 Drive

s3655-066



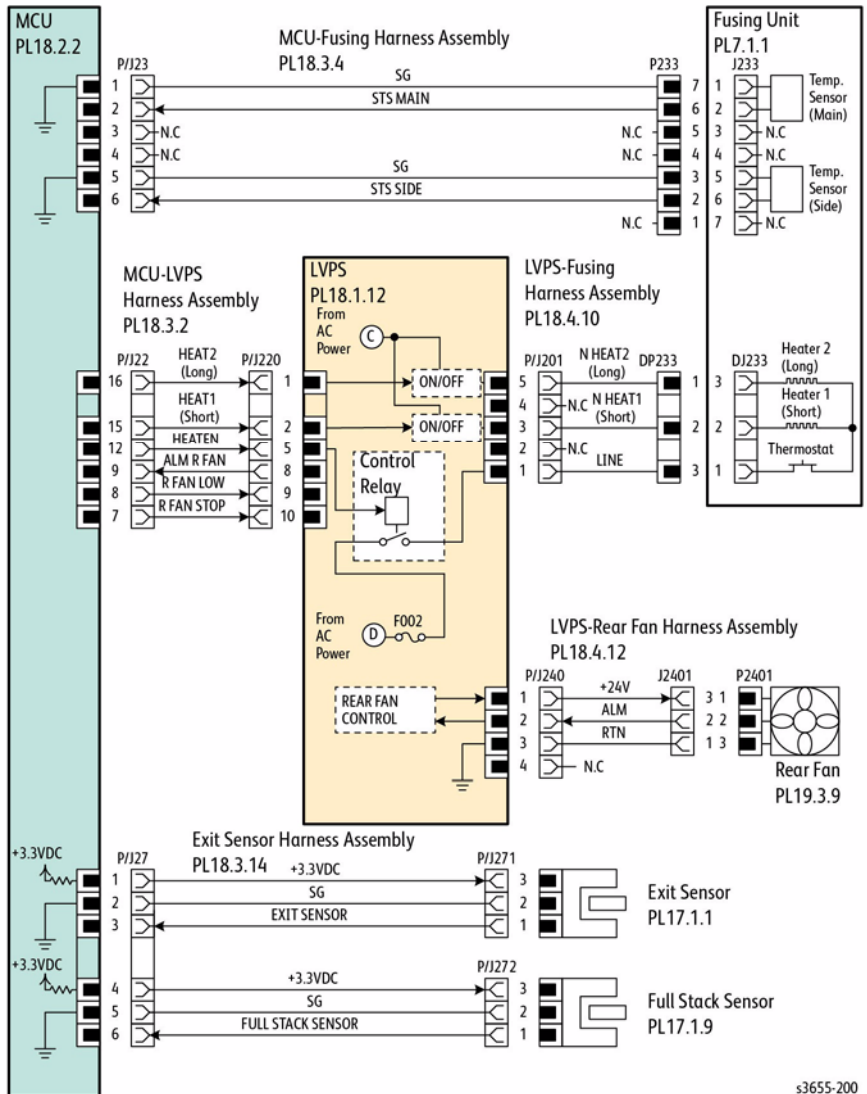

Figure 6 LVPS / Fuser

s3655-200

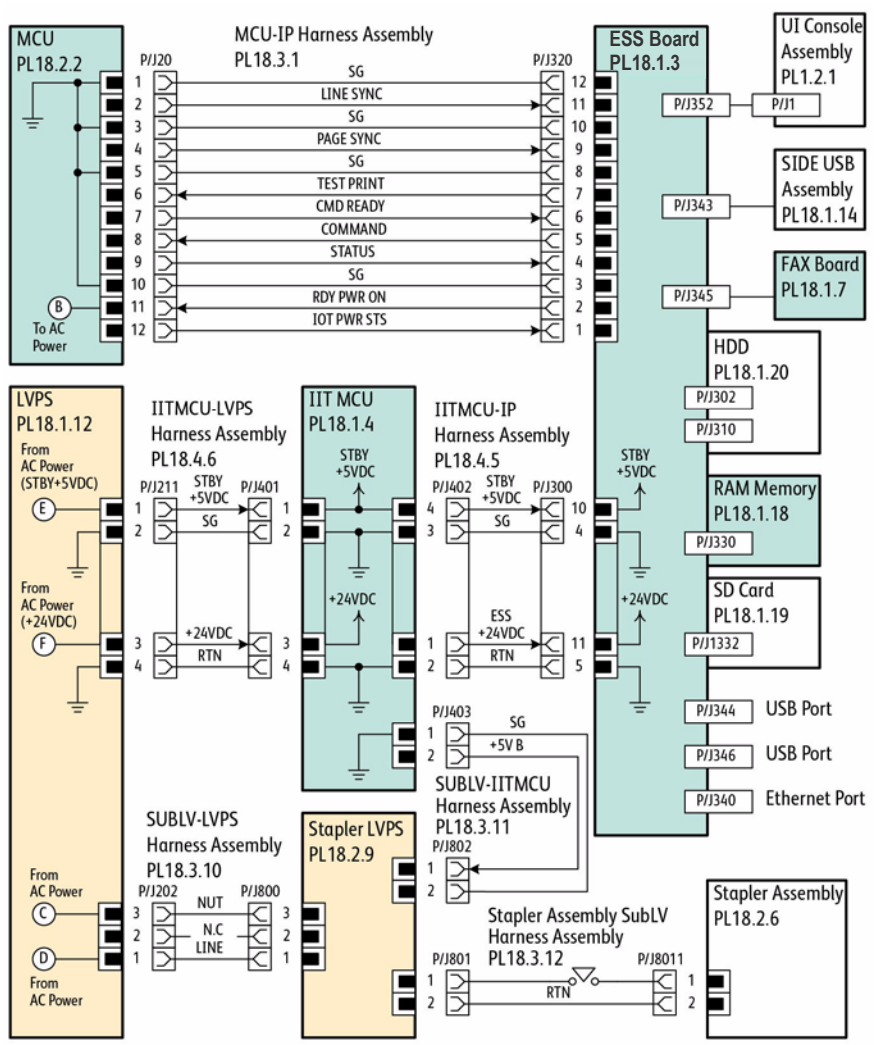

Figure 7 ESS Board

s3655-201

8 Principals of Operation

WorkCentre 3655 Operational Overview	8-3
Media Handling	8-3
Sensors	8-5
Xerographics	8-6
Major IOT Assemblies	8-9
Major IIT Assemblies	8-16
WorkCentre 3655 Options	8-17

WorkCentre 3655 Operational Overview

This section describes the printer's operational characteristics providing detailed descriptions of the media path, sensors, xerographics and major assemblies.

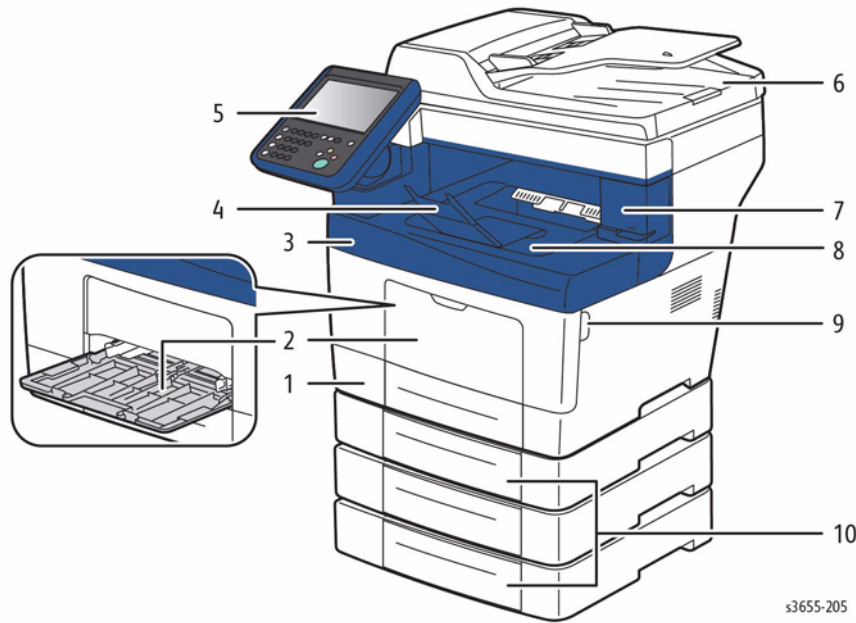

Figure 1 WorkCentre 3655

Front View

- | | |
|--------------------------|-------------------------------------|
| 1. Tray 1 | 6. Automatic Document Feeder (DADF) |
| 2. Bypass Tray | 7. Stapler |
| 3. Top Cover | 8. Output Tray |
| 4. Output Tray Extension | 9. Front Cover Release |
| 5. Control Panel | 10. Optional 550-sheet Feeder |

Media Handling

Media is driven along the media path by various drive motors, belts, gear assemblies and rollers. Synchronization of these components is managed by the MCU Board. The operating system monitors sensors located along the media path throughout the print engine, DADF, and attached options. As a sheet travels along the media path, sensors change state temporarily to indicate the sheet's presence. If the pattern of sensor state changes differs from the expected timing for a particular paper size and path, an error is reported.

Input Media Path

Figure 1 illustrates how media is transported through the printer.

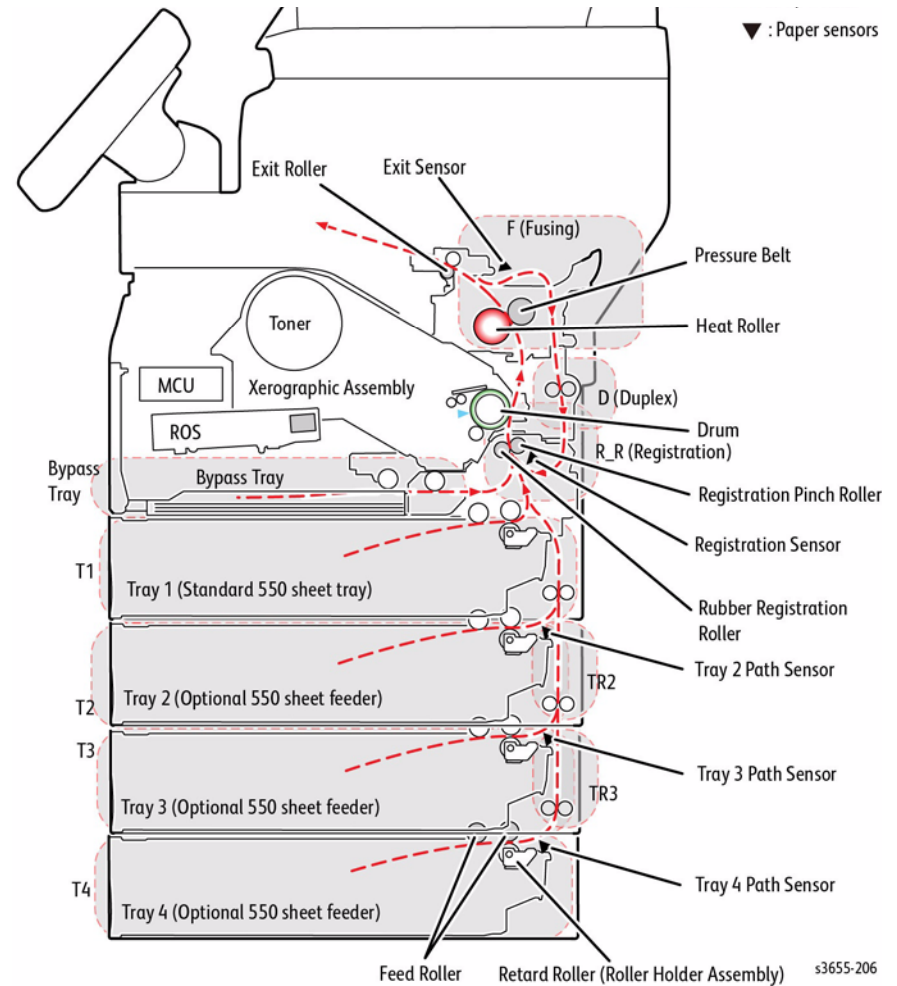

Figure 1 IOT media path

Figure 2 shows how media moves through the DADF.

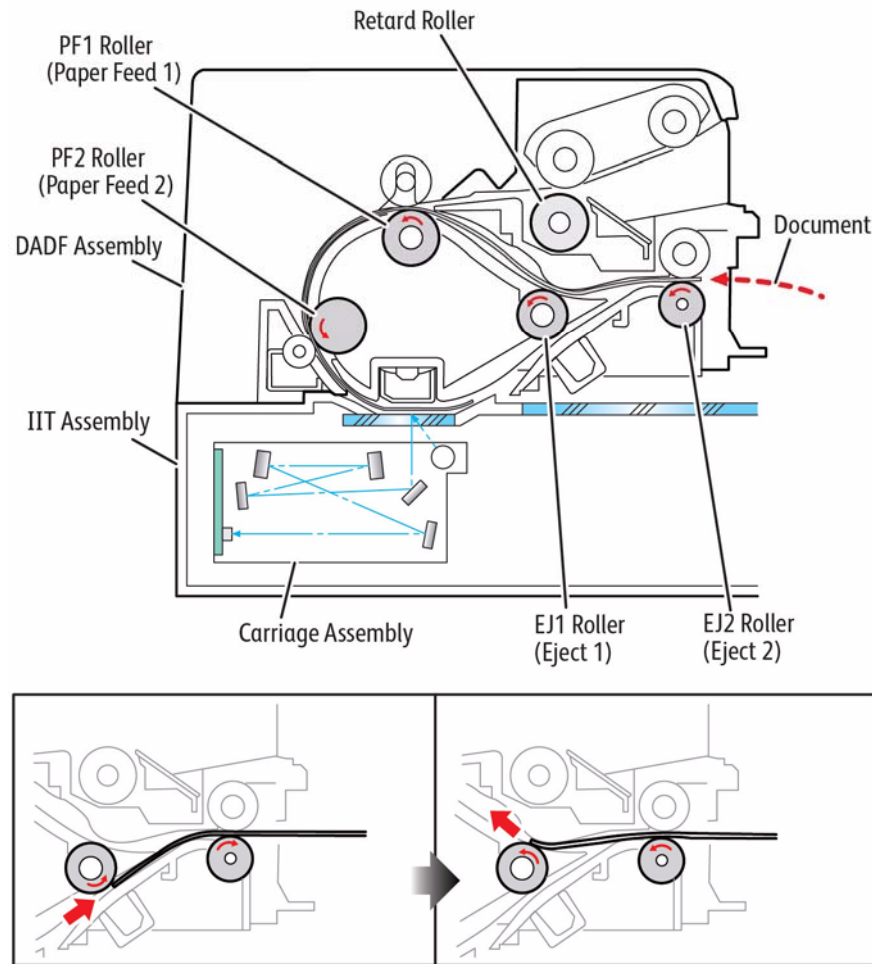

Figure 2 DAF media path

Bypass Tray

When feeding media from Tray 1, the control logic instructs the mechanical drive to activate the Feed Roller. When the control logic calls for media feed, it sends a feed signal to momentarily energize the Tray 1 Pick Clutch causing the Feed Roller to rotate. When the Feed Roller contacts the paper, a sheet is fed into the gap between the Feed Roller and the Pinch Rollers.

Tray 1

When the control logic calls for media feed, the Nudger Roller moves the sheet to the Feed Roller. The Feed Roller moves a single sheet out of the tray and toward the tray's Take Away Roller. The Retard Roller ensures only one sheet is fed. The media then moves past the Path Sensor and up the vertical path driven by the Take Away Roller. The media continues along the path until the sheet reaches the Registration Roller.

Trays 2 through 4

Feeder operation of the optional 550-sheet feeders is much the same as Tray 1. Optional feeders employ similar feeder components.

Output Media Path

The path for media exiting the Fuser is through the Exit Assembly to the Output Tray on the Front Cover Assembly.

Output Tray

The Output Tray is a face-down, 250-sheet tray located on the Front Cover Assembly. The tray receives media from the Exit Assembly.

Sensors

The printer contains sensors of various types that perform a variety of functions. One group of sensors track media as it moves along the paper path to detect jams. Other sensors detect the presence of the Drum Cartridge, stop printer activity if a door is open (interlock), and monitor the fusing temperature.

Sensor Types

The types of sensors used vary with function. In general, there are three types in use.

Photo Sensors

Two types of photo sensors are used, photo-reflective and photo-receptive. Photo-reflective sensors use light reflected back from an object to detect its presence. Photo-receptive sensors use an actuator or the object itself to block the light path to detect an object or condition.

Photo-reflective sensors have the light emitter and light receiver aligned on a single surface. Output of the photo-receptor is High ($> +4.5$ V) when light is being reflected back and Low ($< +3$ V) when it is not. Photo-receptive sensors consist of a LED in one arm of a U-shaped holder, and a photo-transistor in the other arm. When the sensing area is vacant, nothing is between the arms of the sensor, light falls on the photo-receptor sending the signal High. If the light is interrupted, the photo-transistor goes Low. .

Thermistors

Thermistors have a known value of resistance whose value varies with temperature. Used primarily in the Fuser for temperature sensing.

Microswitches

Microswitches are used primarily as cover interlocks in the printer. They are in a normally open state, and close when actuated. A bank of microswitches is used to detect paper size in the universal trays. Microswitches also employ hooks or catches for retention in the bracket or frame. Figure 1 shows Interlock Switch locations.

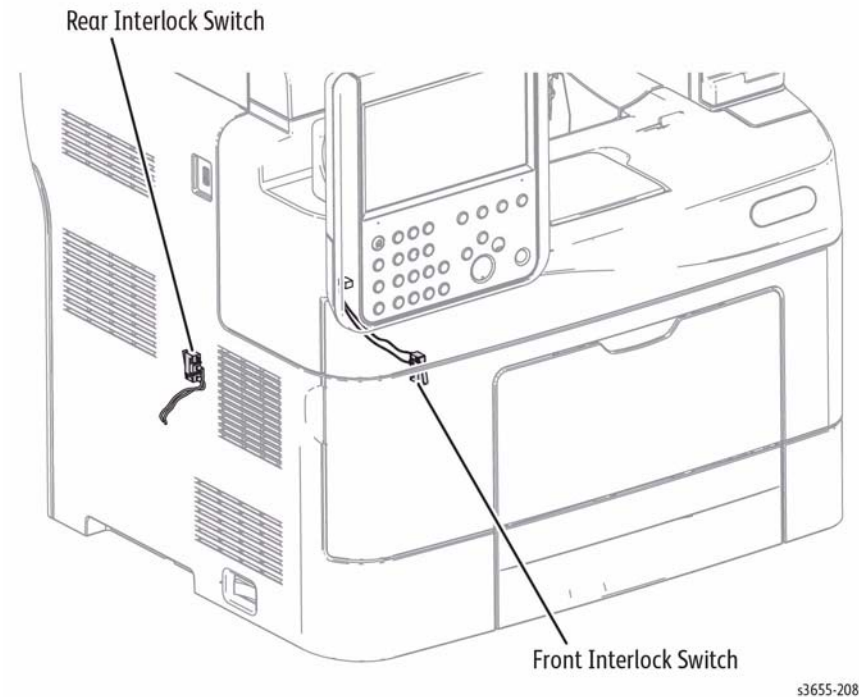

Figure 1 Interlock switch locations

Sensors in the Media Path

Table 1 lists the location and designation of sensors located in the media path. Error detection is based on media transport timing through the sensing area. Figure 2 shows the location of some of these sensors.

Table 1 List of Sensor and Interlock Functions

Name	Type	Function
MSI No paper	Photo-receptive	Signals no media in Bypass Tray
Registration	Photo-receptive	Signals leading edge at registration
Path	Photo-receptive	Signals media exit from feeder
Exit	Photo-receptive	Signals media exit from Fuser
Stack Full	Photo-receptive	Signals output tray full
Tray 1 No paper	Photo-receptive	Signals no media in Tray 1
ADC	Photo-reflective	Monitors Toner density
Rear Interlock	Microswitch	Signals Rear Cover open
Front interlock	Microswitch	Signals Front Cover open
Size Switch	Microswitch	Signals media size in tray

Table 1 List of Sensor and Interlock Functions

Name	Type	Function
Legal	Photo-receptive	Signals Legal media in DADF Input
Environmental	pcb	Monitors temperature and humidity
Internal temp	Thermistor	Monitors internal temperature

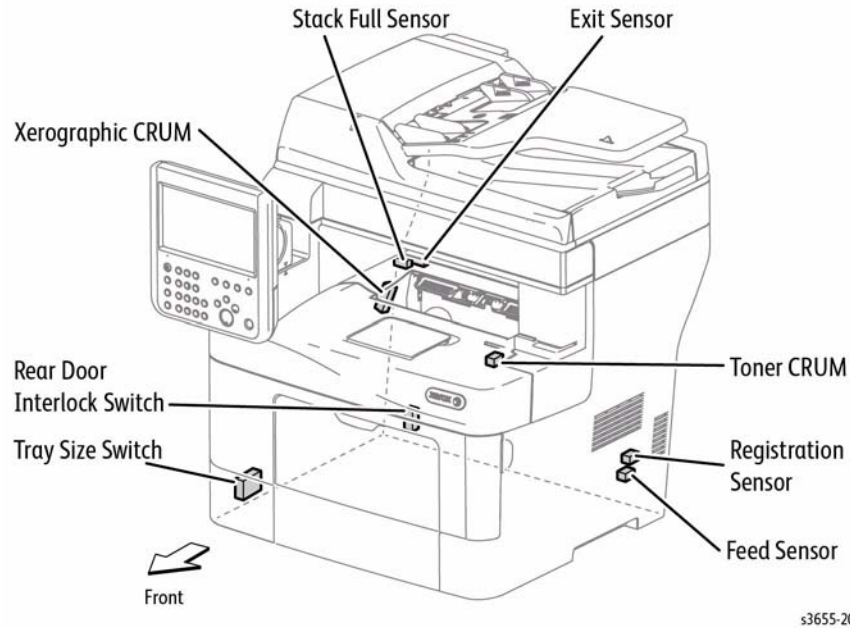

Figure 2 IOT Sensor Locations

Media Size Sensing

Tray 1 and optional feeders detect media size using an array of microswitches (Size Switch) mounted in the tray cavity. When the tray end guide is adjusted, the guide changes the Size Switch actuator positions. Actuating different combinations of the Size Switch produces different combinations of high and low signals. These signals identify what size media is loaded and what to display on the Control Panel. Also, actuation of the Size Switch signals the tray is present and closed to the MCU Board.

Media Present Sensing

When the last sheet is fed from any tray, the No Paper Sensor actuator drops to block the No Paper Sensor. Feeding is inhibited until media is loaded into the tray.

Xerographics

Drum Cartridge

The Drum Cartridge, Figure 1, holds the Toner Cartridge and is reached through the Front Cover. The Drum Cartridge is a customer-replaceable item. The Drum Cartridge consists of OPC drum and development unit. The OPC drum has a scorotron which charges the OPC, a light-guide and cleaning blade. The development unit has a magnetic roller, mixing augers, developer, a Dr-blade and an ADC sensor.

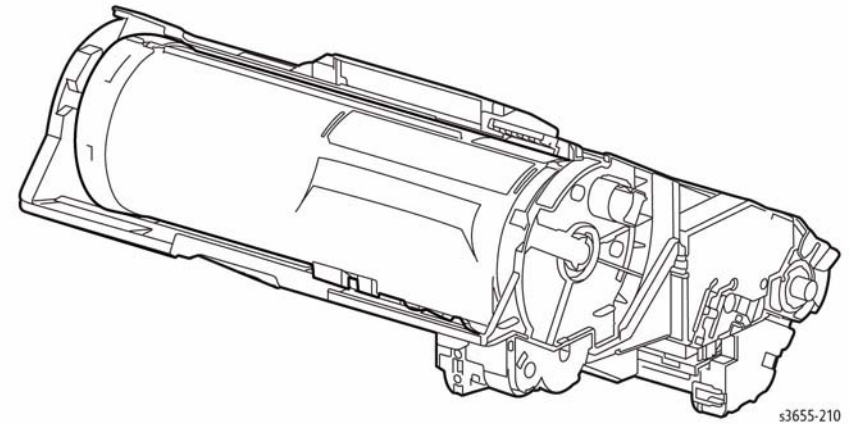

Figure 1 Drum Cartridge with Toner

Table 1 Drum Cartridge Components

Component	Function
Drum	The Drum is an aluminum cylinder coated with a layer of photo-conductive material that retains electrical charges on its surface until exposed to light, when electrical conduction occurs.
Magnetic Roller	A thin layer of developer and toner adheres to the surface of this roller, which transports the toner to the Drum surface.
Charging and Metering (Dr) Blade	The CM Blade controls the thickness of developer and toner over the Magnet Roller, and applies negative charges to the toner.
Cleaning Blade	The Cleaning Blade removes toner remaining on the Drum.

Transfer Roller

The Transfer Roller, Figure 2, located on the Rear Cover Assembly is driven by direct contact with the OPC drum. When media moves between the Transfer Roller and drum, the Transfer Roller applies a positive charge to the rear surface of the media. The negatively charged, developed image on the drum is attracted by the media's positive charge and is transferred from the drum to the media.

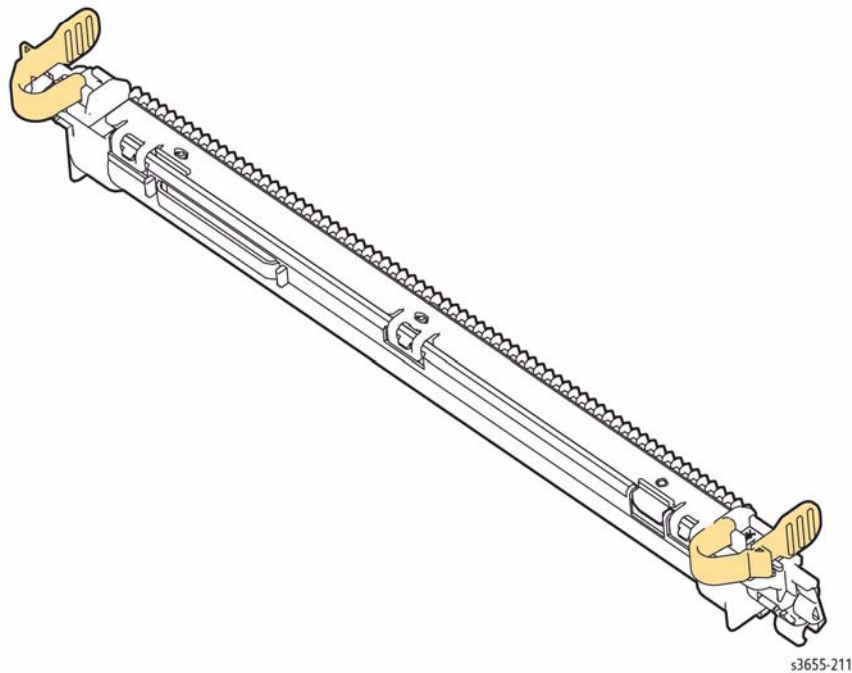
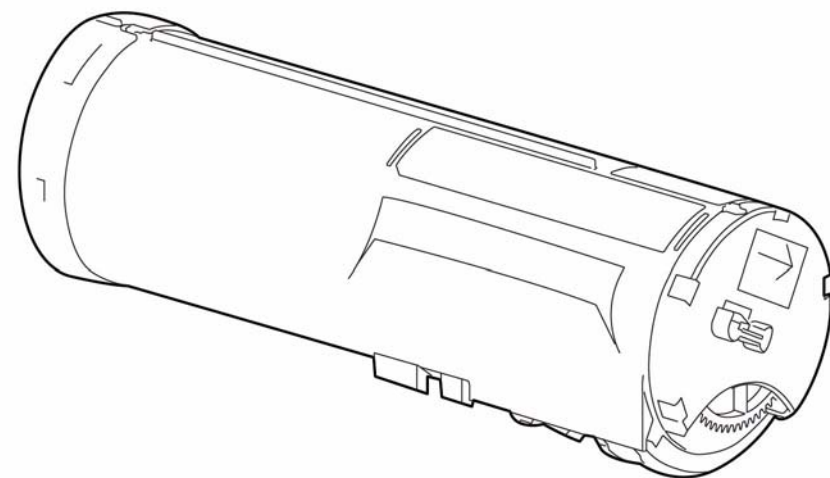

Figure 2 Transfer Roller

Toner Cartridge

The Toner Cartridge, Figure 3, is installed in the Drum Cartridge and locked into position.



s3655-212

Figure 3 Toner Cartridge

Waste Toner Recovery

Excess toner is collected through a series of augers and deposited into the Drum Cartridge.

Laser Unit

The Laser Unit, Figure 4 interprets signals from the ESS Board and scans the surface of the drum with a laser to create a latent image. The dual-beam laser scans from one end of the drum surface to the other while being turned off and on forming a single line of a latent image. The resolution of the dual-beam laser is either 600 dpi or 1200 dpi and is determined by the customer setting. Both beams are always on. For 600 dpi, both beams receive the same data. For 1200 dpi, the beams receive different data resulting in a smaller pixel size. The scanner motor turns On when it receives a signal, and turns Off after printing ends. The motor remains Off in the standby and power-saving states.

Table 3 Scanner Motor Operational Modes

Operational Mode	Laser Power On/Off
Print Mode	Turns On upon receiving the signal from the controller, and turns Off after a preset time has passed from the end of printing. Also turns Off if a print command is not received within 30 seconds from the reception of the signal.
Sleep Mode	Always Off

Fuser

The Fuser, Figure 5, using a combination of heat and pressure, bonds the toner to the media. As a CRU, the Fuser is replaced as a unit.

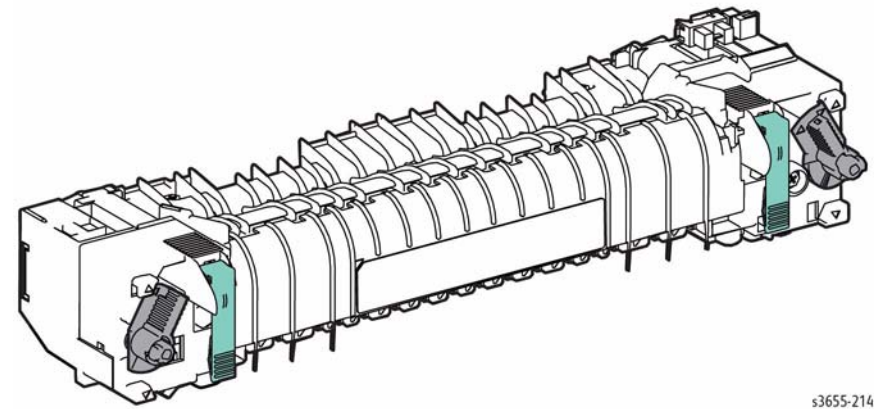

Figure 5 Fuser

The Fuser receives its drive from the Main Drive Assembly. After the toner image is transferred to the media, the media passes through the Fuser. The pressure roller is pressed against the heat roller to melt the toner and bond the image to the media.

To better understand Fuser errors, Fuser components are described below.

Table 4 Fuser Components

Component	Function
Heat Roller	The Heat Roller is a metal tube with a coated surface and a Heat Lamp inside. As media passes between the Heat Roller and Pressure Roller, the heat fuses the toner to the media.
Pressure Roller	The Pressure Roller maintains pressure on the media passing between it and the Heat Roller. This pressure bonds the melted toner to the paper.
Heat Lamp	The Heat Lamp is a quartz glass tube containing heater coils. The Heat Lamp heats the entire length of the Heat Roller.

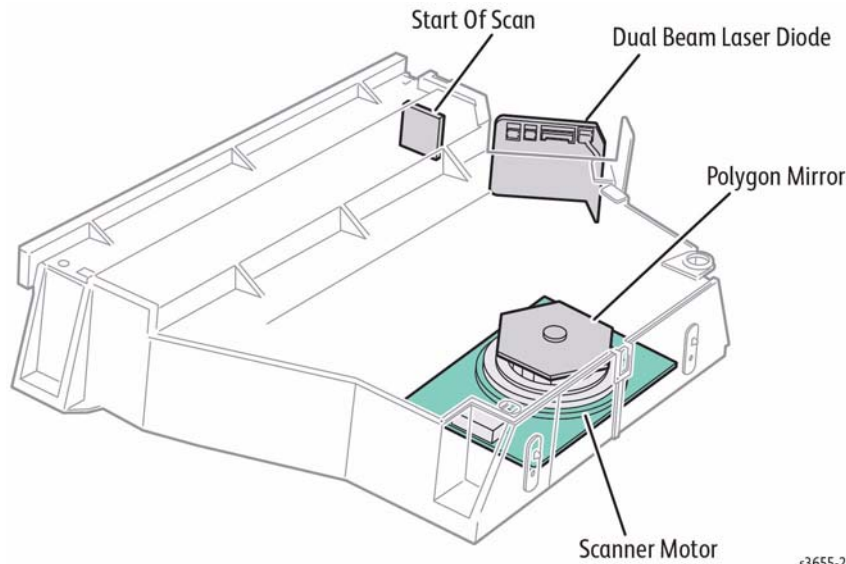

Figure 4 Laser Unit components

CAUTION

Never remove the cover from a Laser Assembly for any reason - contamination may result.

The Laser Unit consists of four components: the laser diode (LD) Assembly, the scanner assembly, lenses and mirrors, and the start of scan (SOS) board.

Table 2 Laser Assembly Components

Component	Function
Laser Diode Assembly	Produces two laser beams that are turned on and off according to the print data signal.
Scanner Assembly	Consists of a faceted polygonal mirror mounted on the shaft of the scanner motor that reflects the beams to the drum surface through lenses and mirrors, to scan the beams across the drum.
Start of Scan Board	When the laser beams strike the sensor on the SOS board, the signal generated indicates the initial position of the scan. The initial position where a scan is started on each line is detected.

Scanner motor control is performed according to the mode of operation as shown below.

Table 3 Scanner Motor Operational Modes

Operational Mode	Laser Power On/Off
Standby Mode	Always Off

Table 4 Fuser Components

Component	Function
Temperature Sensors	These are Thermistors having a known value of resistance that varies with temperature. There are three Temperature Sensors in the Fuser. One is located at the center of Heat Roller, the other is located where the edge of a letter size sheet of paper comes through. The third is located at the center of the Pressure Roller. The sensors monitor the surface temperature of the Heat and Pressure Rollers.
Thermostat	The Thermostat provides a second-level of protection. If the Heat Roll temperature exceeds the preset temperature, the Thermostat cuts off the AC power to the Heater Rods.

Fuser Life Expectancy

The life expectancy of the Fuser is 200,000 Letter/A4 size pages. Several factors can reduce Fuser life:

- Greater than 5% coverage
- Printing on heavy media
- Printing on transparencies or specialty media

Power Shutoff to the Fuser

The printer shuts off power to the Fuser for the following reasons:

- Fuser error
- Jam error
- Cover open
- Laser Unit error
- CPU or NVRAM error
- Rear Fan error

Major IOT Assemblies

Components of the WorkCentre 3655 multifunction printer described in this section include:

- Trays
- Duplex
- Exit Assembly
- Drive and Electrical

Trays

Standard trays include the 100-sheet, multi-purpose Bypass Tray and 1 550-sheet universal tray, Tray 1. The trays adjust to accept various media sizes.

Bypass Tray

A sheet is fed from the MSI (Multi Sheet Inserter) when the MSI Feed Solenoid is turned On, the stopper is released, and the Nudger Roll contacts the top sheet of the stack loaded in the Bypass Tray. The Feed and Nudger Rollers rotate driven by the Main Drive Assembly to feed the sheet to the position where it is nipped between the Feed and Retard Rollers. Figure 1 shows Bypass Tray feed component location.

If multiple sheets are fed together, the friction with the stopper sheet and Retard Roller prevents the bottom sheets from going any further, allowing only the top sheet to pass. Bypass Tray components include:

- Feed Roller
- MSI Feed Solenoid that engages the Main Drive Assembly to the Feed Roller.
- No Paper Sensor, located on the HVPS, detects whether paper is available.

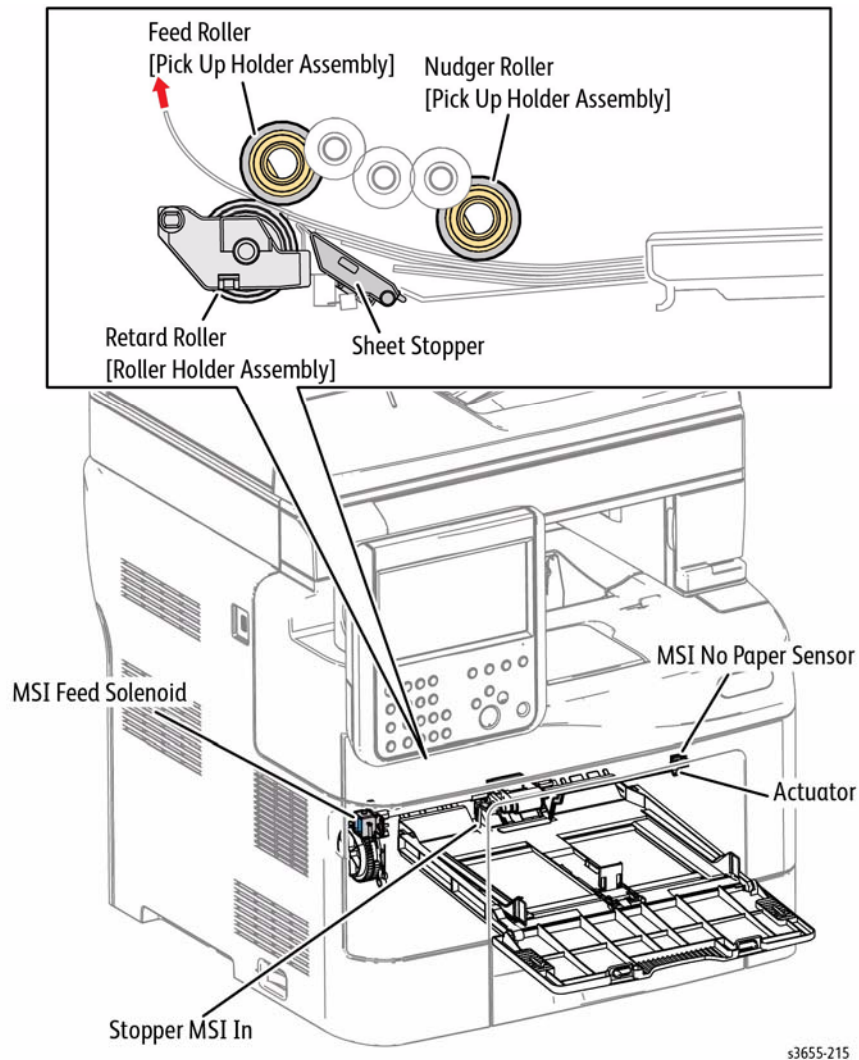

Figure 1 Bypass Tray components

The Bypass Tray incorporates a single set of guides. When media is inserted, the leading edge strikes the actuator of the No Paper Sensor indicating the presence of paper. As the last sheet of paper is fed from the tray the actuator blocks the sensor opening indicating no paper remains in the tray.

Tray 1

The sheet loaded in the Tray are fed by the Nudger Roll to the position where it is nipped between the Feed Roll and the Retard Roll.

The Retard Roll separates the sheets by the rotational friction obtained by being pressurized to the Feed Roll by the spring from below. If multiple sheets are fed together, the Retard Roll is braked to stop by the built-in torque limiter, and prevents, by friction, the bottom sheets from going any further, allowing only the top sheet to pass.

The bottom plate rises by the spring pressure as the stack becomes thinner.

Tray components include, Figure 2:

- **Separator Roller**
The Separator Roller prevents multi-sheet picks from the tray by applying drag to the bottom of each passing sheet.
- **End and Side Guides**
The End and Side Guides adjust to different media sizes by moving them to contact the media edges and hold it in position. Size Switch actuators, located on the tray, are set by the position of the end guide to indicate loaded media size.
- **Bottom Plate**
The bottom plate rises by spring pressure to put the media in contact with the Nudger Roller moving the No Paper Sensor actuator.

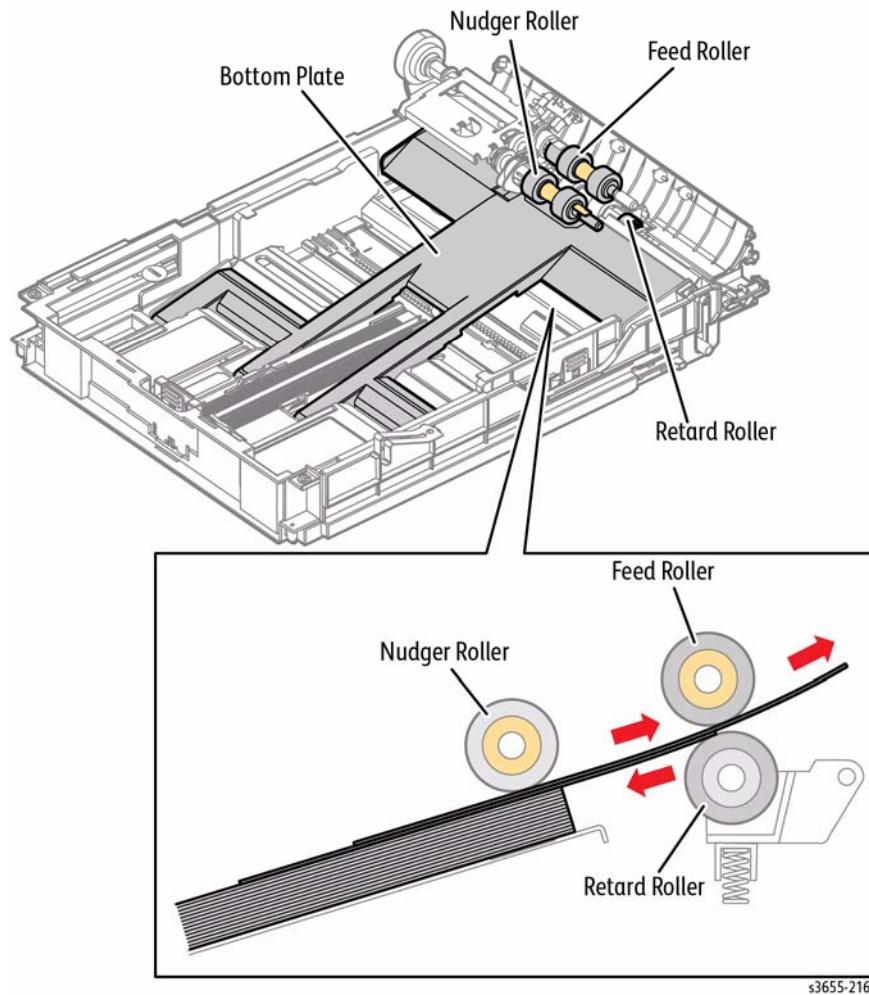

Figure 2 Tray components

Tray 1 and the optional trays are functionally equivalent in terms of the feeder mechanism that moves media from the tray into the media path.

The media supply and path are monitored by these sensors.

- **Path Sensor**
The Path Sensor detects a paper jam in the tray by the paper position and sensor transition time.
- **No Paper Sensor**

The No Paper Sensor, located on the HVPS, uses an actuator to determine whether the tray is empty. When the actuator lowers, the No Paper Sensor signal goes High indicating an empty tray.

Exit Assembly

The Exit Assembly discharges media to the Output Tray or back through the duplex path. Refer to Figure 3 for the locations of Exit Assembly components.

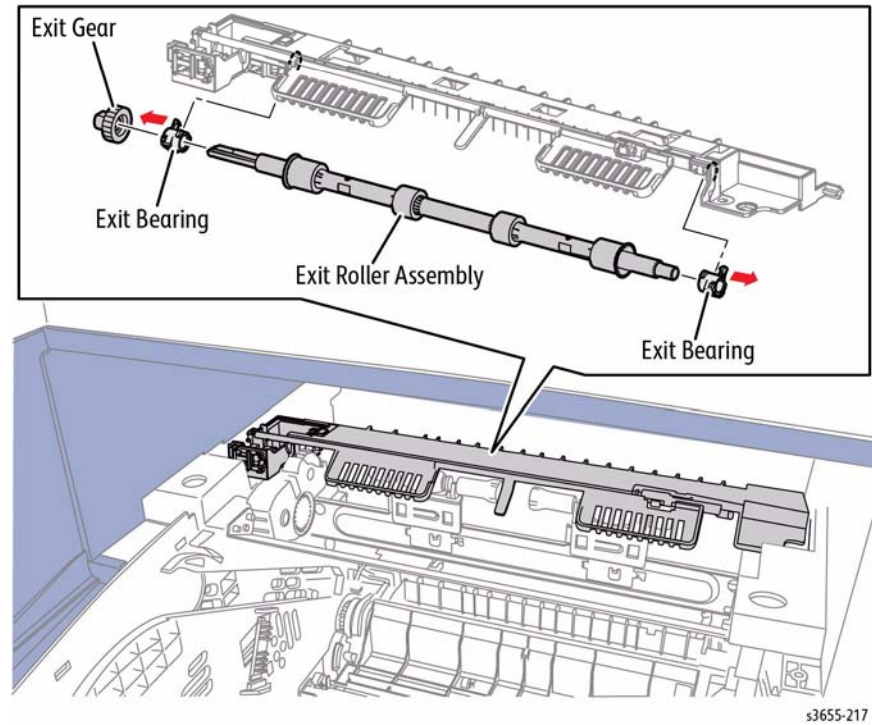

Figure 3 Exit Assembly components

Exit Assembly components include:

- **Exit Roller**
This roller ejects paper to the Output Tray or duplex path.
- **Full Stack Sensor**
This sensor detects that the Output Tray is full, using an actuator.
- **Exit Sensor**
This sensor detects media exiting the Fuser.

Printer Drive

Media is driven through the printer primarily by the Main Drive Assembly. Motion of the Main Drive Assembly is converted by a series of gears, clutches, and solenoids to move media through the print process.

Main Drive Assembly

The Main Drive Assembly gets +24 V power from the LVPS. Motor control signals come from the MCU Board. Figure 4 and Figure 5 show interaction between the Main Drive Assembly and other printer components.

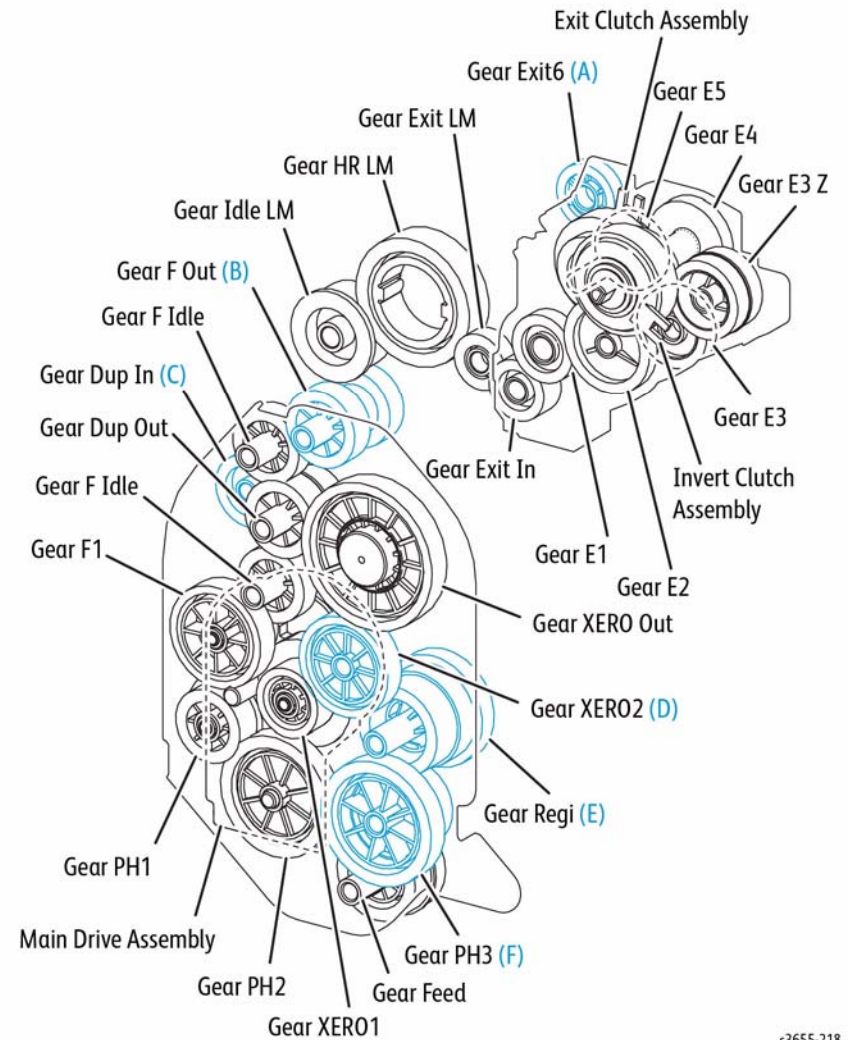

s3655-218

Figure 4 Main Drive Assembly components

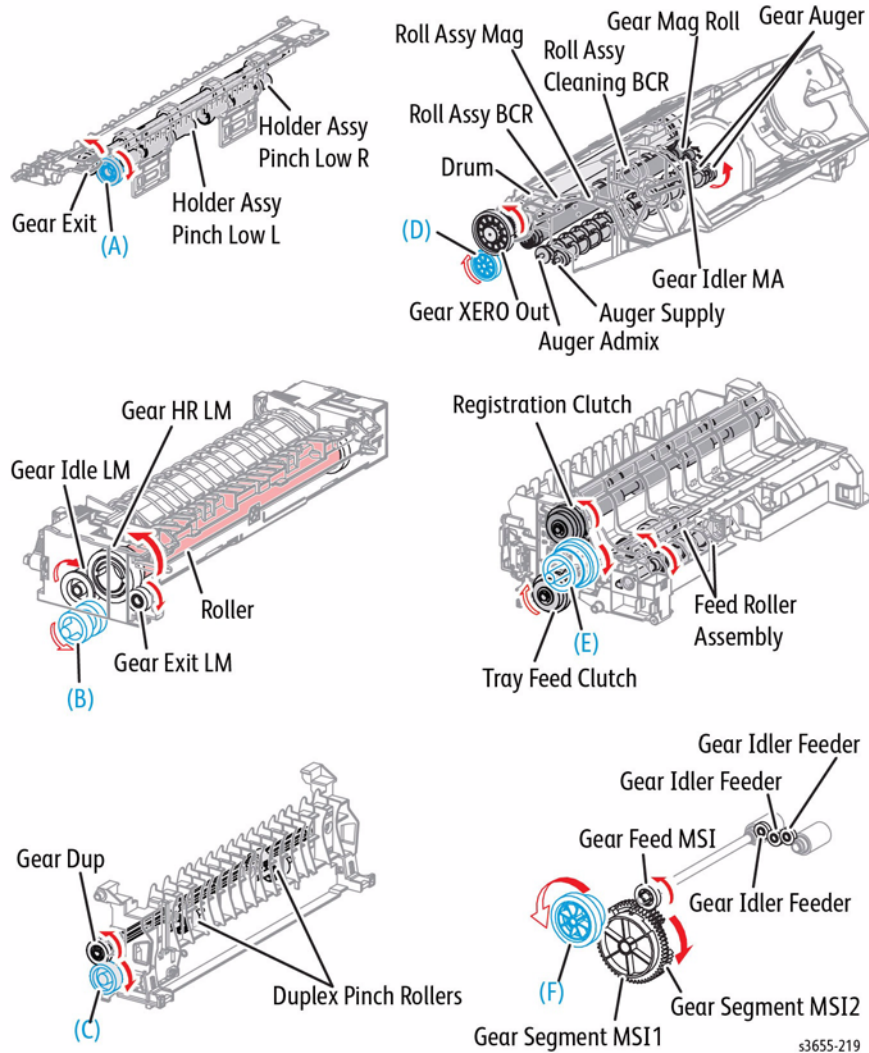

Figure 5 Assembly drive components

Duplex Chute Assembly

Figure 6 illustrates involved componets and media travel through the Duplex Chute and Exit Assembly during duplex operation. After the printing side 1, as the media leading edge passes the duplex gate, the invert clutch is turned On and the exit roller rotates toward the duplex path. The duplex gate lowers under its own weight, and the sheet is fed toward the duplex path. The Duplex Roller rotates driven by a combination of the Duplex Gear and Main Drive Assembly feeds the sheet to the registration position to print side 2.

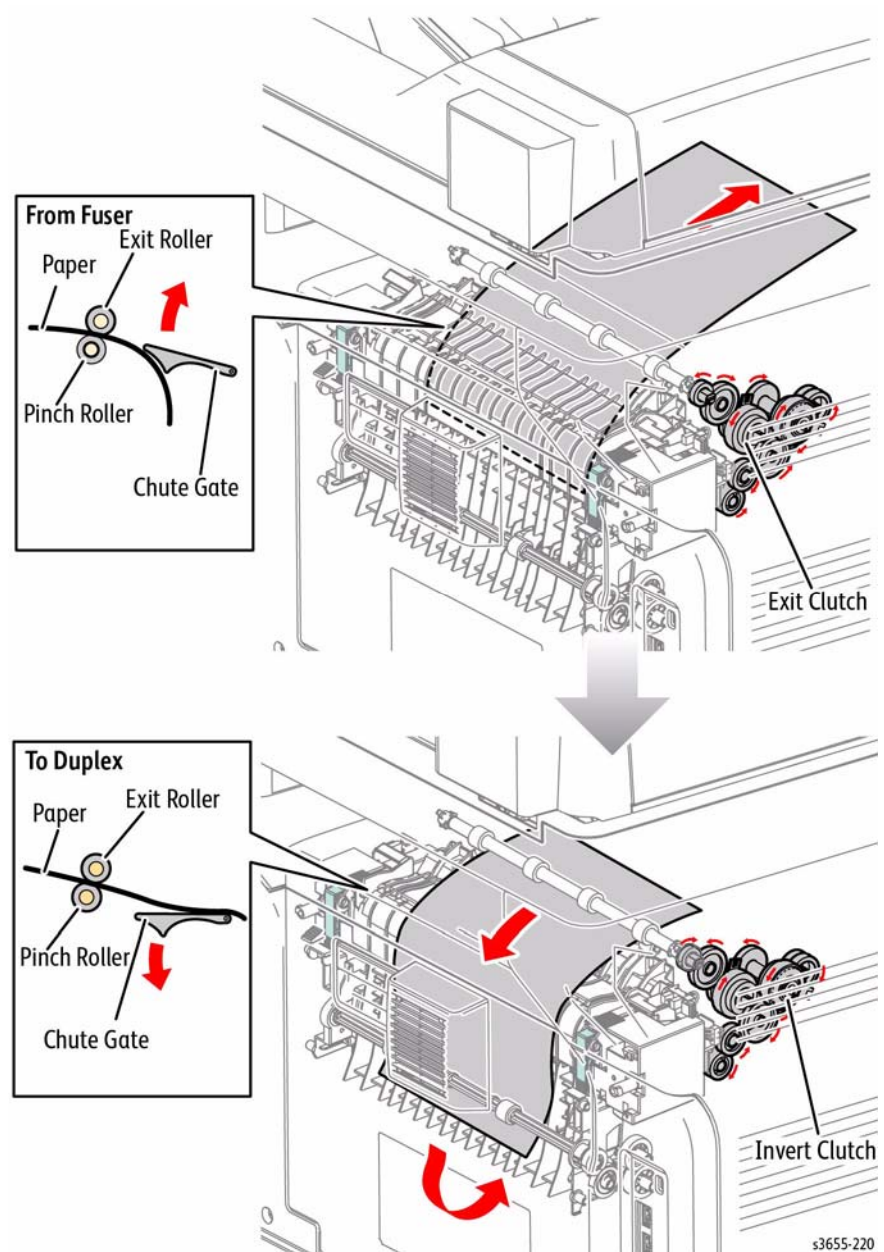

Figure 6 Duplex components

Toner Dispense Motor

Figure 7 shows how the Toner Dispense Motor drives the Toner Cartridge and toner waste augers to dispense and collect toner.

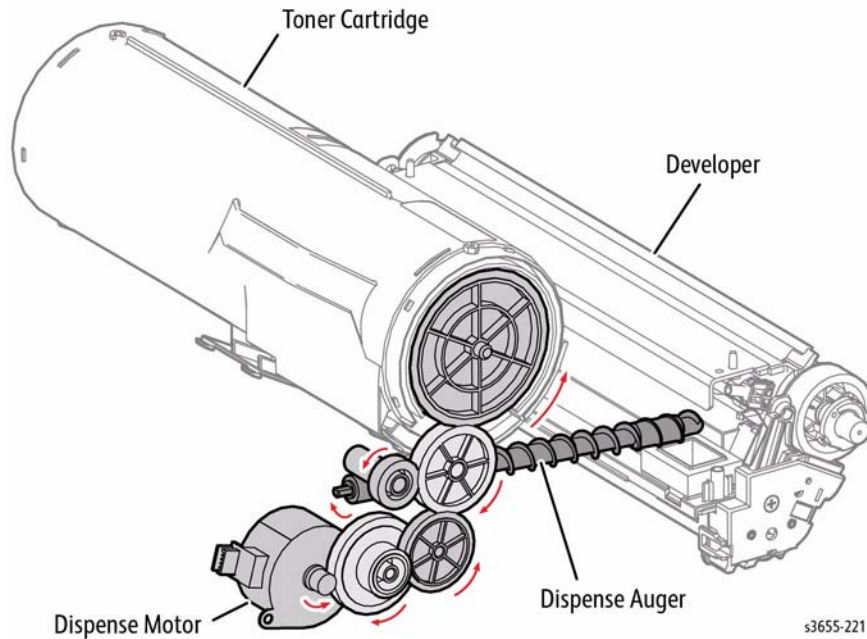

Figure 7 Toner dispense and recovery

Exit Drive Assembly

Figure 8 illustrates the Exit Drive Assembly. The Exit Drive Assembly transfers drive from the Main Drive Assembly to the Exit Chute Assembly to move media to the Output Tray.

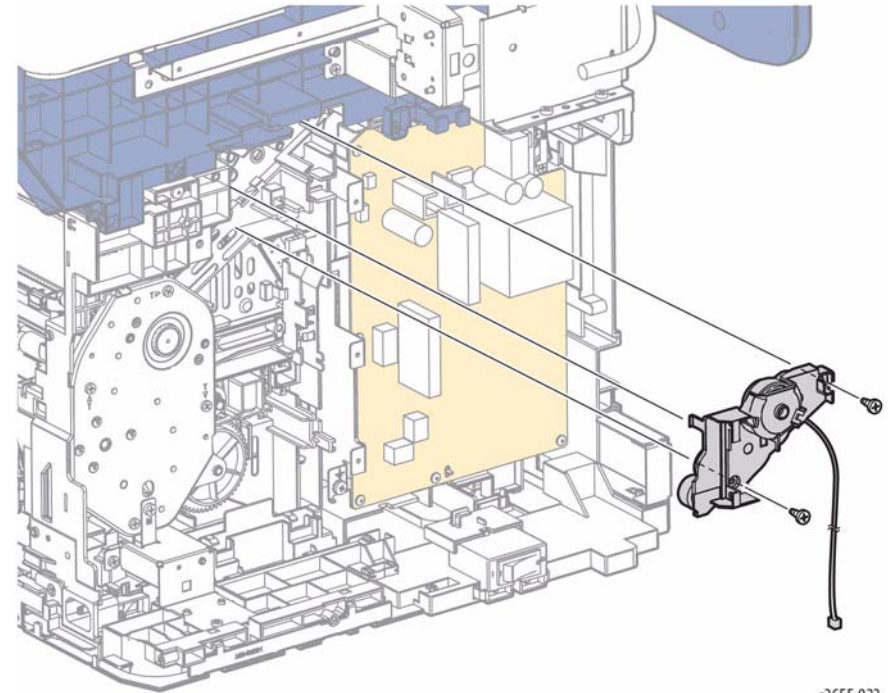
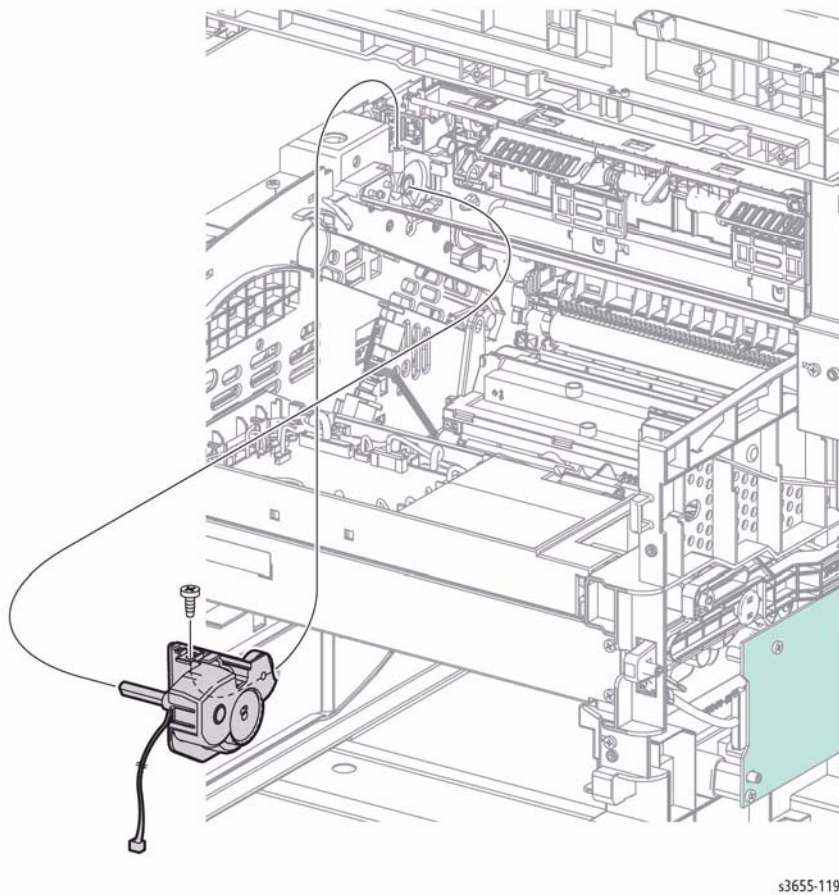

Figure 8 Exit Drive Assembly

Exit Invert Drive Assembly

Figure 9 illustrates the Exit Invert Drive Assembly that includes the exit invert clutch. This clutch in combination with the Duplex Gear drives the Duplex and Exit rollers to move media through the duplex path.



s3655-119

Figure 9 Exit invert Drive Assembly

Printer Electrical

Image Processor Board

The function of the ESS Board is to receive host data, buffer, store, and sent to the print engine in a rasterized format. The secondary function of the ESS Board is to provide print control, Control Panel control, configuration setup, error reporting, and job recovery. The ESS Board connects to the MCU Board directly. The Control Panel is connected to the ESS Board and signals pass through the MCU Board via the I/P Board.

IIT Control Board

The IIT Control Board manages operation of the DADF and Scanner.

MCU Board

The MCU Board manages the printing operation according to information obtained through communications with the ESS Board and from sensors and switches located throughout the printer.

The MCU Board performs these functions:

- Communicates with the Image Processor.
- Controls the print sequence.
- Distributes low DC voltages to various printer components.
- Monitors printer status.
- Maintains a running print count.
- Writes the NVRAM settings.
- Controls printer options.

HVPS

Located behind the Right Side Cover, the High Voltage Power Supply (HVPS) provides high voltage to the OPC drum, magnetic roller, and Transfer Roller.

LVPS

The Low Voltage Power Supply provides regulated power to the ESS, MCU, and IIT Control Boards.

Stapler LVPS

The Stapler LVPS powers the Stapler Assembly.

Stapler

The Stapler provides a convenient way to fasten multiple sheets. Table 1 lists Staple characteristics.

Table 1 Convenience Stapler Characteristics

Feature	Description
Capacity	20 sheets of 80gsm (15 sheets of 90gsm) Capable of Side, Front, Corner and Saddle stapling.
Staple Cartridge	1500 staples
Cycle time	Less than 500 ms
Power/Voltage	24 VDC +/- 2.4V
Current	Less than 2 A
Audible noise	LpAFmax 67 dB och LpApeak 86 dB by rapid noise test regulation
Jam protection	Stapler comes back to home position after operation.
Durability	50,000 cycles

Major IIT Assemblies

IIT assemblies described in this section include:

- Scanner
- DADF

Scanner Assembly

Scanner Assembly components described below and appear in Figure 1:

- Carriage Motor
The stepping motor that drives the Carriage Assy.
- Scanner Home Position Sensor
The Carriage Assy frame functions as an actuator and blocks the scanner home position sensor, thus detecting the registration position.
- CCD PWB
The circuit board mounted with the CCD image sensor that inputs the image data.

Document scanning is performed by the carriage assembly in the Scanner Assembly. The carriage assembly, driven by the carriage motor, consists of the LED array for illuminating a document, the CCD image sensor for photo electronic converting image data, the mirrors, and the lens. The Carriage Assy in the IIT moves at the shifting speed corresponding to the set magnification and irradiates the document by the LED array. The optical image of the document irradiated by the LED array is reflected by the multiple mirrors, passed through the lens, and then scanned by the CCD image sensor. The Scanner Assembly is replaced as a single FRU. No component spare parts are available.

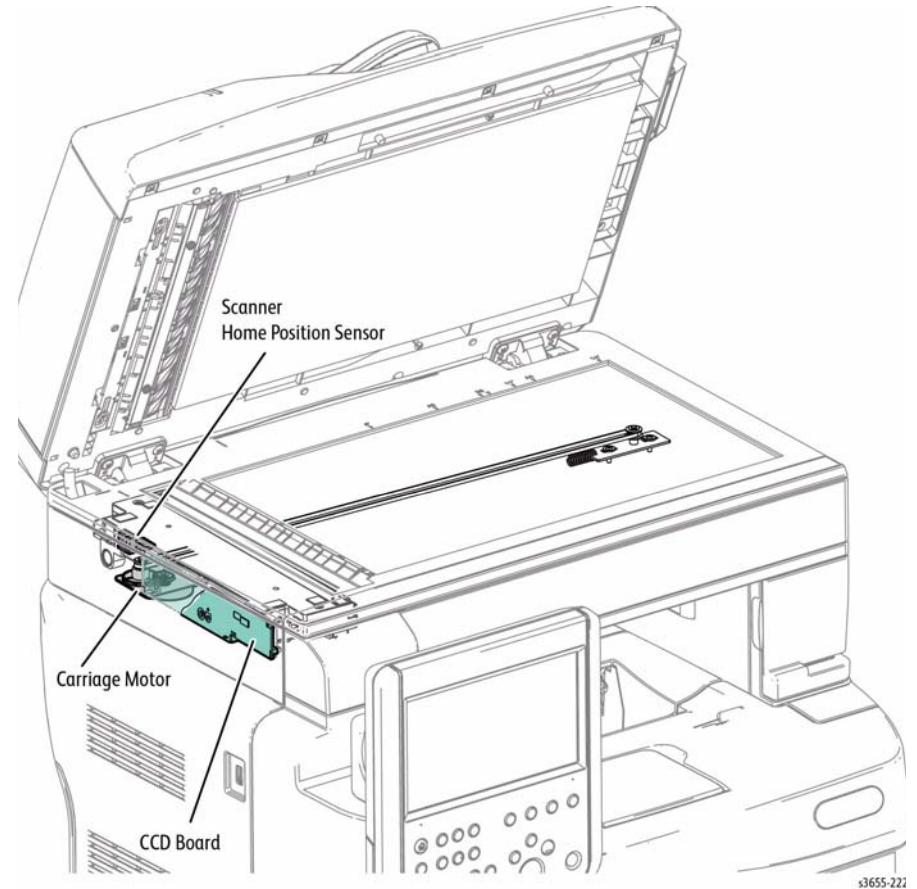

Figure 1 Scanner components

DADF Assembly

DADF Assembly components described below and appear in Figure 2:

- Tray Sensor
Detects the presence or absence of a document on the DADF Document Tray.
- DADF Cover Sensor
Detects whether or not the DADF Top Cover is open.
- Feed Sensor
Located near side of the Scanner Home Position (CVT: Constant Velocity Transport) and detects the scanning timing.
- DADF Stage Sensor

Detects that the document has been fed from the Tray. Also, detects that the reverse side is nipped into the duplex feed path by the Eject2 Roller, after scanning the front side is completed.

- DADF Motor
The DADF motor rotates the Paper Feed1, Paper Feed2, Eject1 and Eject2 Rollers.
- Pick Motor
The pick motor rotates the Pickup Roller and Separation Roller.
- DADF Document LED
If a document is detected by Tray Sensor, DADF document LED lights up.

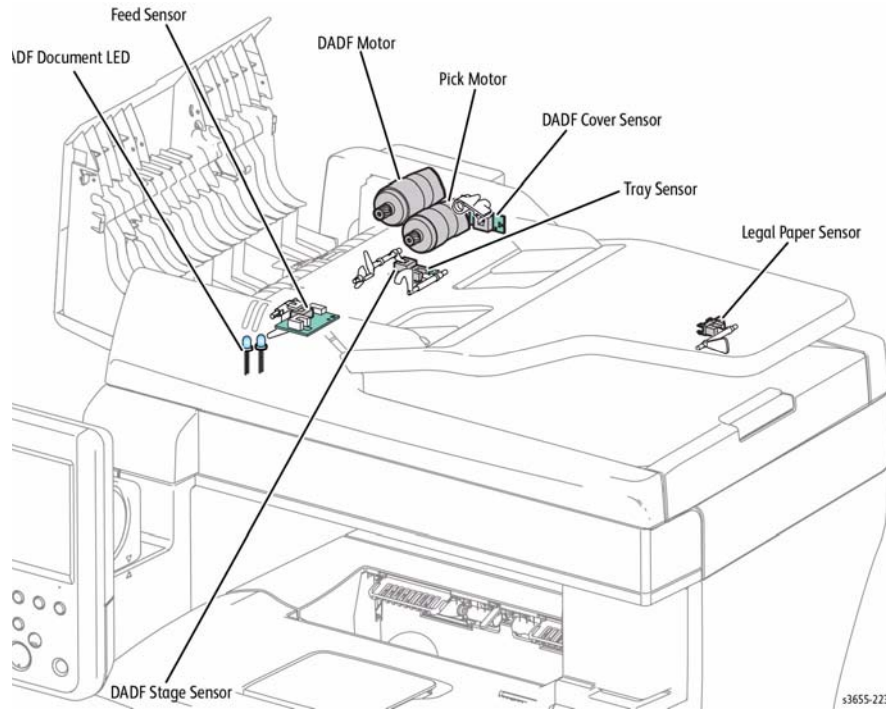

Figure 2 DADF components

When a document is loaded in the DADF, the document stopper is locked to prevent the document from being moved forward. When the DADF starts feeding, the front portion of the Pickup Assy is lowered. This unlocks the document stopper and the document is fed.

Documents are fed through between the Pinch Rolls and the Takeaway Roll to the CVT window by the rotation of the Takeaway Roll. When the paper feed is completed, the Pickup Assy returns to its original position

WorkCentre 3655 Options

WorkCentre 3655 options add paper capacity, and functionality. Additional media capacity is also available. Optional 550-Sheet Feeders brings the maximum input media capacity to 2,350 sheets.

This section describes in detail the paper path, sensors, major assemblies, and operational characteristics for each of these options.

- 550-Sheet Feeder
- Wireless Adaptor
- Stand

WorkCentre 3655 options are documented in their respective installation instructions.

Optional 550-Sheet Feeder

When one or more optional 550-Sheet Feeders is installed under the printer, additional 550-sheet universal trays are available extending the media path. These trays are identical to the 550-sheet tray standard with the printer. The feeder assemblies are also identical to those used for Tray 1.

550-Sheet Feeder Feed Assembly

Optional trays are functionally equivalent in terms of the feeder mechanism that moves media from the tray into the printer. The driving force from each feeder's Feed Motor is transmitted via a gear assembly to the Feed and Nudger Rollers, moving paper from the tray into the printer.

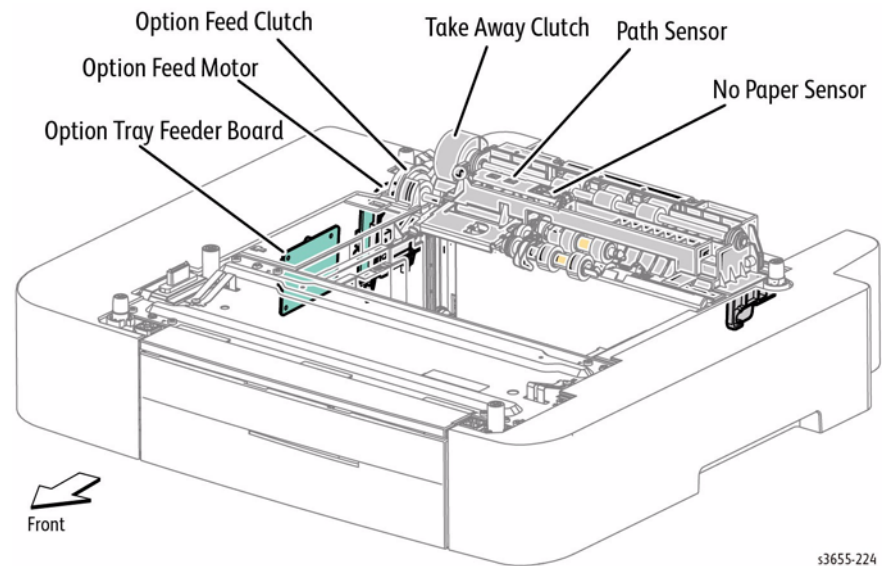

Figure 1 Optional Feeder components

550-Sheet Feeder Drive and Electrical

The 550-Sheet Feeder includes these drive and electrical components:

- Feed Drive Assembly

Figure 2 shows the how the Feed Drive Assembly drives the feed and take away rollers.

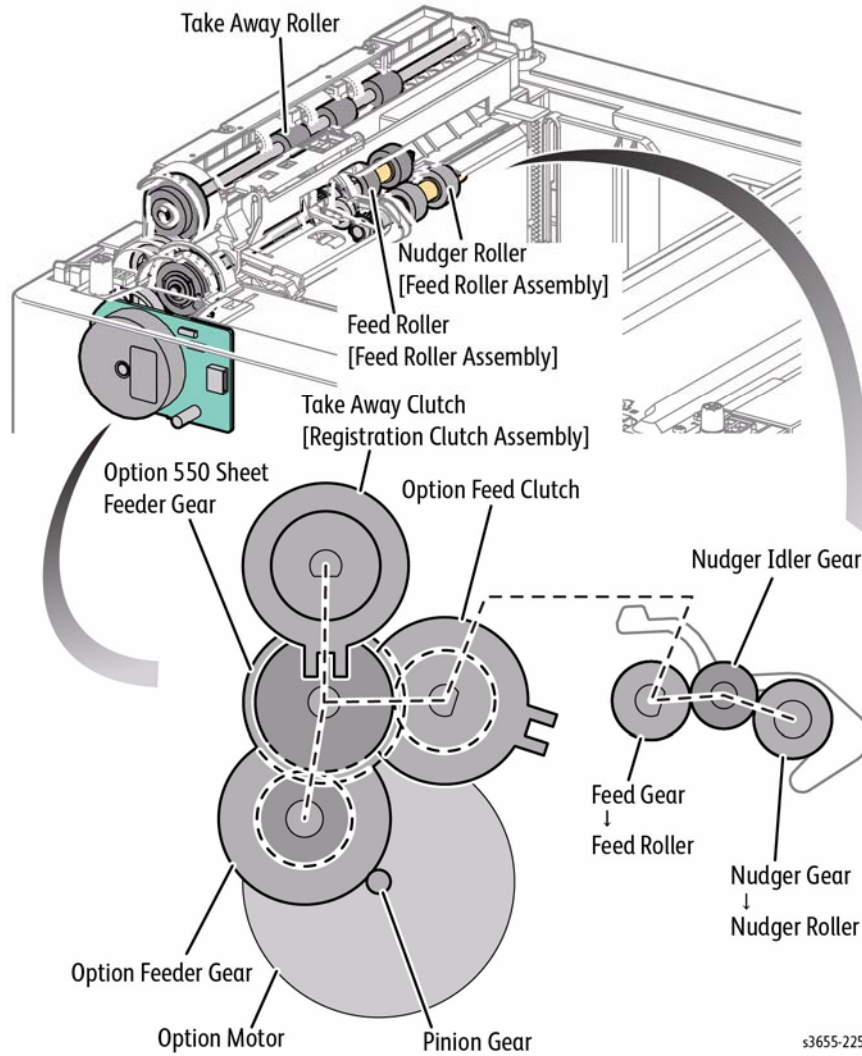

Figure 2 Optional Feeder Feed Drive

- Feeder Board

The Feeder Board, Figure 3, manages control signals and communications from the MCU Board. Feeder power is provided by the SMPS.

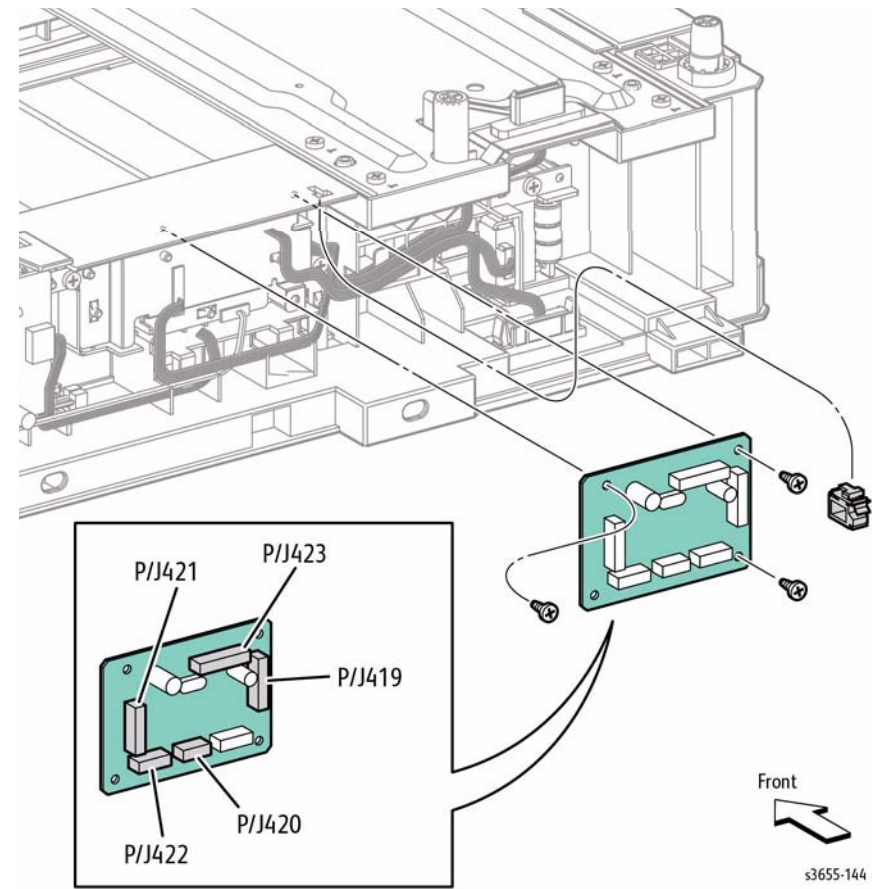

Figure 3 Feeder Board

COPYRIGHT © 2014, XEROX CORPORATION.
ALL RIGHTS RESERVED. UNPUBLISHED
RIGHTS RESERVED UNDER THE COPYRIGHT
LAWS OF THE UNITED STATES.

PART#: 705P01355

